

CASE

HYDRAULIC EXCAVATOR **CX330**



Engine Horsepower	202 kW - 271 hp
Operating weight (max.)	35 t
Bucket capacity	0.74 m ³ to 2.01 m ³

P R O F E S S I O N A L P A R T N E R

ECONOMY AND PERFORMANCE

Electronically-controlled Tier 3A compliant engine featuring common rail diesel injection, for high performance with maximum fuel economy, resulting in improved productivity and lower emissions. **Right for your job site, right for the environment.**

FASTER CYCLE TIMES

Intelligent Computer Command Control System (ICCCS) offers optimum balance of speed, power and control, while ensuring maximum fuel economy in all conditions. Boom priority and hydraulic flow regeneration system increase speed, reducing cycle times and increasing performance. **Power on command, control at all times.**

REDUCED OWNERSHIP COSTS

Extended service intervals and ultra-clean 1 micron hydraulic filter result in 5,000 hour hydraulic oil changes, keeping the machine working even in the harshest operating conditions.

Maximum productivity, minimum downtime.



EASE OF OPERATION

Four engine and hydraulic operating modes allow the operator to match the machine's performance to the individual job application.

Revolutionary auto setting uses ICCCS to instantly change between modes, offering rapid response to changing site conditions. Auto power boost automatically increases power by 8-10 per cent to tackle tough ground or heavy lifting duties.

Operator control, electronic response.

DURABILITY AND BUILD QUALITY

Turntable bearing hub extends through top plate for increased strength, while swivel guard protects internal upperstructure components from damage. Full track guards protect track components and strut-type chain links reduce twisting and point loading.

Durable undercarriage, extended component life.

FASTER TRAVEL

Two speed travel with auto downshift offers traction on tough ground. Track rollers equipped with synthetic oil to reduce heat build up, increasing long term reliability.

Smooth shifting, maximum tractive effort.

LONG LIFE COMPONENTS

EMS chrome plated pins and brass bushes for maximum durability. Greasing on all boom and arm pins (except bucket) at six month/1000 hour intervals.

Reduced maintenance, peace of mind.

EXCEPTIONAL SERVICE ACCESS

Wide opening side panels and walkways to both sides of the machine enable service access to all engine and hydraulic components. A reversible hydraulic fan draws dust and debris from the cooling pack at engine start-up to reduce build-up in the radiators. On-board diagnostics constantly monitor machine status and green plug drain system eliminates ground pollution during regular maintenance.

Ease of service, reduced downtime.

OPERATOR COMFORT

Spacious cab offers excellent all round visibility and high levels of comfort. Isolation mountings reduce vibration and noise in the cab, while climate control provides the perfect working environment for the operator.

Total comfort, total productivity.



STRENGTH TO PERFORM

Heavy duty boom and dipper construction with internal baffles provides strength and durability to resist torsional loads. Choice of four boom/arm configurations, including mass excavation combination for increased productivity in high capacity applications.

The power to dig, built to last.



The Case CX330 is equipped with a proven Isuzu AH-6HK1X-S diesel engine, providing 271 hp (202 kW) of power at an unstressed 2000 rpm.

With high pressure common rail fuel injection, this electronically-controlled motor easily meets the requirements of the EU directive 97/68/EC Tier 3A on engine emissions.

Electronic engine control, in combination with the Case hydraulic Intelligent Computer Command Control System (ICCCS) optimises the fuel injection to meet the load on the engine and hydraulic cylinders. This results in a high level of responsiveness for the operator and more efficient use of fuel, reducing consumption and emissions.

The engine incorporates an automatic warm-up system, which increases engine speed gradually as the correct operating temperatures are reached, preventing premature wear of engine components.



Case excavators are among the toughest on the market, yet they retain the power and speed to perform. Using an Intelligent Computer Command Control System (ICCCS), the CX330 provides the optimum balance of speed, power and fuel efficiency whatever the job.

Boom priority permits faster cycle times in loading operations as the hydraulic oil is prioritised to the main boom circuit during the raise function. The energy created by oil returning from the boom and the dipper arm is regenerated to increase the excavating speed.

In addition there is an auto power boost function which automatically increases the system pressure by 8-10 per cent to power through heavy ground, or to help with heavy lifting duties. The CX330 features an ultra-clean 1 micron hydraulic filter, which provides an exceptional level of filtration, even removing water from the oil. This results in extended hydraulic oil life, with change intervals now set at 5000 hours, reducing downtime and cutting operating costs.



The CX330 enables the operator to have a choice on how the machine is operated. Simply choose the work mode that matches the machine output to the job application.

Four operating modes are available.

H Mode (Heavy)

For heavy excavation or whenever you need extra power.

S Mode (Standard)

For standard digging and loading operations reducing fuel consumption.

L Mode (Light)

For lifting and other operations that need fingertip accuracy.

Auto-Mode

The most revolutionary approach to maximizing power & fuel efficiency available today. Just select the Auto-Mode with the switch panel. Using actual working pressure readings, ICCCS instantly changes modes assuring the best combination of speed and power while you can stay focused on the work at hand.

OPERATOR'S CAB

The CX330's cab offers high levels of comfort, low levels of noise and a climate-controlled working environment. The entire cab is mounted on six shock absorbing rubber and fluid mounts, reducing vibration and noise in the cab for the operator.

A fully adjustable suspension seat is standard equipment, offering height, reach and rake options to ensure that all sizes of operator can find their ideal working position. Automatic climate control maintains the desired temperature in the cab whatever the weather outside.

The cab is a full 1 metre wide, with plenty of room for the operator to store coats and bags out of the working area. Large windscreens and side glazing, along with low bodywork to the rear of the machine, provide excellent all round visibility from the cab. Rear view safety mirrors are also included in the standard specification.



UNDERCARRIAGE/TRANSMISSION



Case has a long tradition of building strong, durable excavators and the CX330 is no exception. A modified X-style carbody is welded internally for added strength, and the turntable bearing hub extends down through the top plate of the carbody for additional structural integrity.

The machine has standard two speed travel motors, with a top speed of 5.5 km/h, making it easy to reposition on site. The motors will downshift automatically when the going gets tough, and compact high torque final drives ensure traction on the steepest grades and in the deepest mud.

MAINTENANCE/ACCESSIBILITY



There are large, wide opening doors to both sides of the machine, making it easy for technicians to access the engine and hydraulic componentry.

The CX330 is equipped with a hydraulically-driven cooling fan, which can be reversed on start-up to blow dust and debris away from the excavator's cooling pack.

The machine benefits from a 580 litre fuel tank, to maximise working time. An auto-stop electric fuel pump is fitted as standard to the machine, to reduce refuelling times and make life easier for the operator.

IMPROVED PIN AND BUSHING LIFE



All boom pins (except the bucket pins) are extended maintenance system (EMS) chrome plated for increased hardness, with lubricated brass bushings fitted through the boom and dipper. Dust seals are double structured to prevent the ingress of dirt and dust on site.

This combination makes it possible to extend lubrication intervals on the boom pins to six months/1,000 hours of operation, cutting downtime and ensuring that the machine keeps working longer.

EMS chrome plated pins with brass bushing

SPECIFICATIONS

ENGINE

Latest generation engine, meeting European requirements for "low exhaust emissions" Tier 3A, in accordance with directive 97/68/EC.

Make _____ ISUZU
 Type _____ AH-6HK1X-S
 Common rail, turbo, intercooler, fuel cooler _____ Yes
 Direct injection _____ electronically controlled
 No. of cylinders _____ 6
 Bore - Stroke _____ 115 x 125 mm
 Cubic capacity _____ 7790 cm³
 EEC 80/1269 horsepower _____ 202 kW - 271 hp
 Engine speed _____ 2000 rpm

HYDRAULIC SYSTEM

Linked to the engine power management electronic system, a second electronic system manages all the hydraulic parameters so as to obtain the highest possible available hydraulic power, under optimum conditions of efficiency and economy. The system consists of two axial piston, variable flow pumps.
 Max output _____ 2 x 284 l/min
 Max safety valve pressure _____
 Attachment/**Power Boost** _____ 343/**373** bar
 Upperstructure swing _____ 294 bar
 Travel _____ 343 bar
 Oil filtration (Ultra Clean) _____ 1 micron

SWING

Axial piston, fixed flow motor
 Max upperstructure swing speed _____ 9.6 rpm

TRAVEL

The travel circuit is equipped with two axial piston, variable flow motors.

Planetary reduction gear, automatic multi-disc brake.
 Max travel speed _____ 5.5 kph
 Low travel speed _____ 3.2 kph
 Speed change is controlled from the instrument panel.
 Gradeability _____ 70% (35°)

ELECTRICAL SYSTEM

Circuit _____ 24 volts
 Batteries _____ 2 x 12 v - 128 A/h
 Circuit equipped with water-proof connectors
 Alternator _____ 24 v - 50 A/h

UNDERCARRIAGE

Upper rollers _____ 2
 Lower rollers _____ 8
 Number of track pads _____ 48
 Type of shoes _____ Triple grouser
 Standard track pad width _____ 600 mm
 Chain guides _____ Front and central (2)

CIRCUIT AND COMPONENT CAPACITIES

Fuel tank _____ 580 l
 Hydraulic reservoir _____ 175 l
 Hydraulic system _____ 350 l
 Travel reduction gear (per side) _____ 11 l
 Swing reduction gear _____ 6 l
 Engine (including filter change) _____ 36 l
 Engine cooling system _____ 30 l

ATTACHMENTS/BUCKETS

CX330 customers can choose from a variety of main booms and dipper arms to suit different applications, all of which are constructed of heavy duty steel box section with internal baffles to increase torsional rigidity. Deep groove welding ensures that the booms and arms can withstand the stress of high breakout forces, heavy lifting and attachments such as hydraulic breakers, compactors, demolition shears and crushers.

With a choice of four dipper sticks, along with a range of buckets from 0.74 m³ - 2.01 m³, there is a configuration to meet the requirements of every customer's job site.

GENERAL PURPOSE

SAE capacity	l	740	940	1150	1360	1580	1800	2010
Width	mm	750	900	1050	1200	1350	1500	1650
Weight	kg	770	820	910	1000	1150	1230	1330

HEAVY DUTY

SAE capacity	l	740	940	1150	1360	1580	1800	2010
Width	mm	750	900	1050	1200	1350	1500	1650
Weight	kg	864	938	1096	1243	1350	1429	1537

EXTRA HEAVY DUTY

SAE capacity	l	1360
Width	mm	1200

QUARRY

SAE capacity	l	2010
Width	mm	1650
Weight	kg	1660

For other bucket sizes, please contact your CASE dealer

GENERAL DIMENSIONS

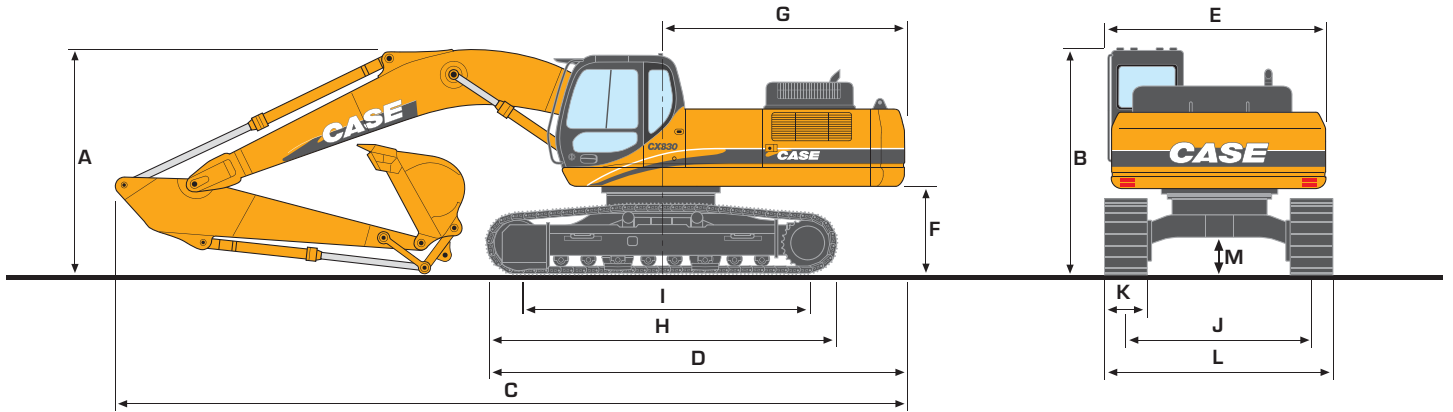

			LC	NLC
A Overall height	Dipper 2.20 m	m	3.60	3.57
	Dipper 2.60 m	m	3.53	3.53
	Dipper 3.25 m	m	3.29	3.29
	Dipper 4.00 m	m	3.51	3.51
B Cab height		m	3.13	3.13
C Overall length	Dipper 2.20 m	m	11.25	11.25
	Dipper 2.60 m	m	11.13	11.13
	Dipper 3.25 m	m	11.05	11.05
	Dipper 4.00 m	m	11.09	11.09
D Overall length (wo/ attachment)		m	5.91	5.91
E Width of upperstructure		m	3.04	3.04
F Upperstructure ground clearance		m	1.21	1.21
G Swing (rear end) radius		m	3.42	3.42
H Track overall length		m	4.98	4.98
I Centre/centre (idler to sprocket)		m	4.04	4.04
J Track gauge		m	2.60	2.39
K Track shoes width (std)		mm	600	600
L Track overall width	- Shoes 600 mm	m	3.20	2.99
	- Shoes 700 mm	m	3.30	3.09
	- Shoes 800 mm	m	3.40	3.19
M Ground clearance		m	0.48	0.48

WEIGHT AND GROUND PRESSURE

STANDARD CONFIGURATION 6.45 m BOOM

CX 330 LC

With operator, full fuel tank, lubricant, coolant, bucket*

	650 mm		750 mm		900 mm	
	WEIGHT (kg)	GROUND PRESSURE (bar)	WEIGHT (kg)	GROUND PRESSURE (bar)	WEIGHT (kg)	GROUND PRESSURE (bar)
Dipper 2.20 m	33996	0.64	34307	0.55	34618	0.49
Dipper 2.65 m	34038	0.64	34349	0.56	34660	0.49
Dipper 3.25 m	34101	0.64	34412	0.56	34723	0.49
Dipper 4.00 m	34435	0.65	34746	0.56	35057	0.50

CX 330 NLC

Dipper 2.20 m	33796	0.64	34107	0.55	34418	0.49
Dipper 2.65 m	33838	0.64	34149	0.56	34460	0.49
Dipper 3.25 m	33901	0.64	34212	0.56	34523	0.49
Dipper 4.00 m	34235	0.65	34546	0.56	34857	0.50

*Bucket weight: 1170 kg



PERFORMANCE DATA

WITH 6.45 m MONOBLOC BOOM

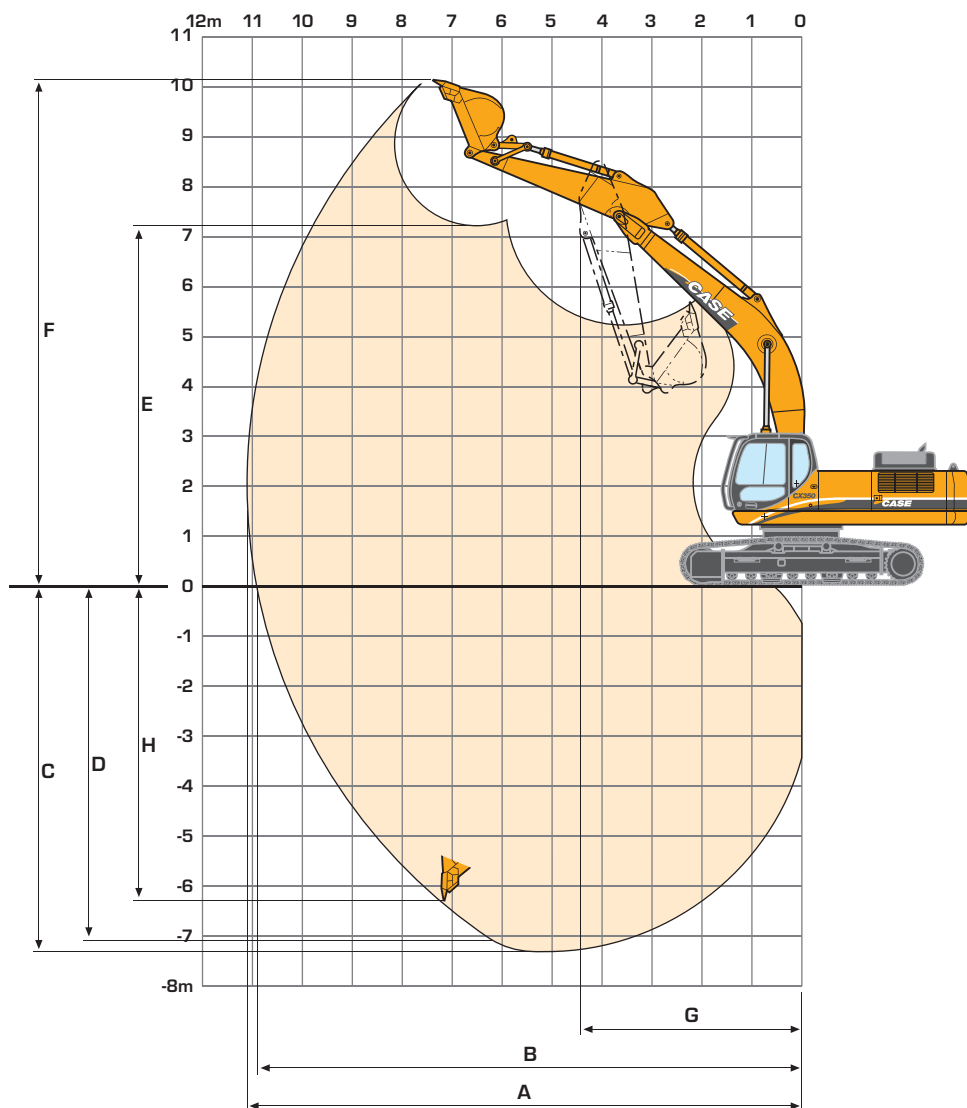

DIPPER LENGTH

		2.20 m	2.60 m	3.25 m	4.00 m	
A	Maximum digging reach	m	10.20	10.67	11.17	11.90
B	Maximum digging reach at ground level	m	9.99	10.47	10.98	11.72
C	Maximum digging depth	m	6.30	6.73	7.34	8.14
D	Digging depth - 2.44 m level bottom	m	6.10	6.55	7.19	8.01
E	Max dump height	m	6.77	7.14	7.23	7.54
F	Overall reach height	m	9.85	10.32	10.37	10.67
G	Minimum swing radius - attachment	m	4.66	4.63	4.50	4.56
H	Vertical straight wall dig depth	m	5.08	5.97	6.35	7.15
	Digging force (w/o Power Boost)	daN	22700	19500	16400	14050
	Breakout force (w/o Power Boost)	daN	22880	22880	22880	22880
	Digging force (with Power Boost)	daN	24600	21100	17800	15260
	Breakout force (with Power Boost)	daN	24840	24840	24840	24840



LIFTING CAPACITY

CX330 LC WITH 6.45 m MONOBLOC BOOM

Values are expressed in kilos

Front 360°	REACH											
	3.0 m		4.5 m		6.0 m		7.5 m		9.0 m		At max reach	

With 2.20 m dipper, 600 mm shoes and bucket

7.5 m												8850*	8450	6.3
6.0 m					9450*	9000	8650*	6050				8650*	5850	7.7
4.5 m			13600*	13300	10600*	8450	9100*	5850				7950	4900	8.3
3.0 m			16650*	11850	12000*	7800	9050	5500				7250	4400	8.6
1.5 m			18450*	10950	12400	7250	8750	5200				7050	4200	8.6
0 m			18500*	10650	12050	6950	8500	5050				7200	4300	8.4
-1.5 m	18750*	18750*	17550*	10700	11950	6850	8450	5000				7950	4700	7.8
-3.0 m	20050*	20050*	15600*	10950	12000*	7000						9650	5650	7.0
-4.5 m			12050*	11400								9800*	8300	5.5
-6.0 m														

With 2.60 m dipper, 600 mm shoes and bucket

7.5 m												8100*	7400	6.9
6.0 m							8150*	6150				6650*	5050	8.3
4.5 m					10000*	8550	8650*	5850				6750*	4350	8.9
3.0 m			15750*	12200	11500*	7900	9100	5550	6700	4050		6550	3950	9.1
1.5 m			18000*	11150	12450	7300	8750	5200	6550	3900		6350	3750	9.2
0 m			18600*	10700	12050	6950	8500	5000				6500	3800	9.0
-1.5 m	15950*	15950*	18000*	10650	11900	6800	8400	4900				7000	4150	8.5
-3.0 m	22050*	22050*	16350*	10800	11950*	6850	8450	5000				8250	4850	7.6
-4.5 m	17350*	17350*	13300*	11200	9950*	7150						9100*	6600	6.4
-6.0 m														

With 3.25 m dipper, 600 mm shoes and bucket

7.5 m							6350*	6350*				6000*	6000*	7.6
6.0 m							7400*	6250				4500*	4500*	8.8
4.5 m					9150*	8750	8050*	5950	6550*	4250		4600*	3900	9.4
3.0 m	13700*	1370*	14400*	12700	10750*	8050	8900*	5600	6700	4050		4850*	3550	9.6
1.5 m	7150*	7150*	17150*	11500	12250*	7450	8800	5250	6500	3850		5350*	3400	9.7
0 m	10550*	10550*	18450*	10850	12150	7000	8500	5000	6350	3750		5900	3450	9.4
-1.5 m	15450*	15450*	18400*	10650	11900	6800	8300	4850				6300	3650	9.0
-3.0 m	21450*	21450*	17300*	10700	11850	6750	8300	4850				7250	4250	8.2
-4.5 m	20350*	20350*	14850*	10950	11150*	6950						8950*	5450	7.1
-6.0 m			10250*	10250*								8600*	8600*	5.2

With 4.00 m dipper, 600 mm shoes and bucket

7.5 m												4400*	4400*	8.6
6.0 m									5350*	4400		3350*	3350*	9.6
4.5 m							7050*	6000	6600*	4250		3400*	3250	10.1
3.0 m			12300*	12300*	9450*	8200	8000*	5600	6700	4000		3600*	3000	10.4
1.5 m	12100*	12100*	15500*	11750	11150*	7500	8750	5200	6450	3800		3900*	2850	10.4
0 m	11400*	11400*	17500*	10800	12100	6950	8400	4850	6200	3600		4350*	2850	10.2
-1.5 m	14250*	14250*	18200*	10350	11700	6600	8150	4650	6100	3450		5150*	3000	9.8
-3.0 m	18550*	18550*	17700*	10250	11550*	6450	8050	4550	6050	3450		5950	3350	9.1
-4.5 m	23050*	21850	16050*	10400	11650	6550	8100	4650				7300	4150	8.1
-6.0 m	17750*	17750*	12750*	10850	9300*	6850						8150*	6050	6.5

- Machine in «LIGHT» mode
- Lift capacities are taken in accordance with SAE J 1097 / ISO 10567 / DIN 15019-2.
- Lift capacities shown in kg do not exceed 75% of the tipping load or 87% of the hydraulic lift capacity.
- Capacities that are marked with an asterisk are hydraulic limited

LIFTING CAPACITY

CX330 NLC WITH 6.45 m MONOBLOC BOOM

Values are expressed in kilos

Front 360°	REACH											
	3.0 m		4.5 m		6.0 m		7.5 m		9.0 m		At max reach	

With 2.20 m dipper, 600 mm shoes and bucket

7.5 m												8850*	7750	6.3
6.0 m					9450*	8250	8650*	5550				8650*	5300	7.7
4.5 m			13600*	12100	10600*	7700	9100*	5300				7900	4450	8.3
3.0 m			16650*	10650	12000*	7050	9000	5000				7250	4000	8.6
1.5 m			18450*	9800	12350	6550	8700	4700				7000	3800	8.6
0 m			18500*	9500	12000	6250	8500	4550				7200	3850	8.4
-1.5 m	18750*	18750*	17550*	9550	11900	6150	8450	4500				7900	4200	7.9
-3.0 m	20050*	20000	15600*	9750	12000*	6300*						9600	5100	7.0
-4.5 m			12050*	10250								9800*	7500	5.5
-6.0 m														

With 2.60 m dipper, 600 mm shoes and bucket

7.5 m												8100*	6800	6.9
6.0 m							8150*	5600				6650*	4600	8.3
4.5 m					10000*	7800	8650*	5350				6750*	3900	8.9
3.0 m			15750*	10950	11500*	7150	9050	5000	6650	3650		6500	3550	9.1
1.5 m			18000*	9950	12450	6600	8700	4700	6500	3500		6300	3400	9.2
0 m			18600*	9550	12000	6250	8450	4500				6450	3450	9.0
-1.5 m	1600*	16000*	18000*	9500	11850	6100	8350	4400				6700	3700	8.56
-3.0 m	22050*	19700	16350*	9650	11950	6150*	8450	4500				8250	4350	7.6
-4.5 m	17350*	17350*	13300*	10000	9950*	6450						9100*	5950	6.4
-6.0 m														

With 3.25 m dipper, 600 mm shoes and bucket

7.5 m							6350*	5850				6000*	5650	7.6
6.0 m							7400*	5700				4500*	4100	8.8
4.5 m					9150*	7800	8050*	5450	6550*	3850		4600*	3550	9.4
3.0 m	13700*	13700*	14400*	11500	10750*	7350	8900*	5100	6700	3650		4850*	3200	9.6
1.5 m	7150*	7150*	17150*	10300	12250*	6750	8750	4750	6500	3500		5350*	3050	9.7
0 m	10550*	10550*	18450*	9700	12100	6300	8450	4500	6350	3350		5850	3050	9.4
-1.5 m	15450*	15450*	18400*	9500	11850	6100	8300	4350				6300	3300	9.0
-3.0 m	21450*	19450	17300*	9550	11800	6050	8300	4350				7200	3800	8.2
-4.5 m	20350*	20000	14850*	9800	11150*	6250						8950*	4900	7.1
-6.0 m			10250*	10250*								8600*	8200	5.2

With 4.00 m dipper, 600 mm shoes and bucket

7.5 m												4400*	4400*	8.6
6.0 m									5350*	4000		3350*	3350*	9.6
4.5 m							7050*	5500	6600*	3850		3400*	2950	10.1
3.0 m			12300*	11950	9500*	7500	8000*	5100	6650	3600		3600*	2650	10.4
1.5 m	12100*	12100*	15500*	10550	11150*	6750	8750	4700	6400	3400		3900*	2500	10.4
0 m	11400*	11400*	17500*	9600	12050	6200	8350	4350	6200	3200		4350*	2500	10.2
-1.5 m	14250*	14250*	18200*	9200	11650	5900	8100	4150	6050	3050		5150*	2650	9.8
-3.0 m	18550*	18550*	17700*	9100	11500	5750	8000	4050	6050	3050		5950	3000	9.1
-4.5 m	23050*	19000	16050*	9250	11600	5850	8100	4150				7250	3700	8.1
-6.0 m	17750*	17750*	12750*	9650	9300*	6150						8150*	5400	6.5

- Machine in «LIGHT» mode
- Lift capacities are taken in accordance with SAE J 1097 / ISO 10567 / DIN 15019-2.
- Lift capacities shown in kg do not exceed 75% of the tipping load or 87% of the hydraulic lift capacity.
- Capacities that are marked with an asterisk are hydraulic limited

CX330

STANDARD EQUIPMENT & OPTIONS

STANDARD EQUIPMENT

Hydraulic control

- 4 working modes (3 manual + 1 auto)
- 2 travel speeds with automatic speed change
- Swing brake control
- Load-holding valves on boom and dipper
- Power control - automatic powerboost
- Hydraulic control lever locking, lever position adjustment
- Auxiliary circuit control valve section
- High performance "Ultra Clean" filtration system (1 µ)

Engine control

- Common rail engine to Tier 3 standard
- Electrical control on injection pump
- Automatic / manual engine return to idle
- Fuel level check
- Emergency stop
- Automatic engine pre-heating

System Monitor, with 14 language display

- Messages (Function, safety, etc.)
- Working modes (H-S-L and Auto)
- Operating modes (travel mode, swing locking, etc.)
- Audible warning device
- Digital clock
- Water temperature
- Hydraulic oil temperature
- Diagnostic system

Electrical system

- Leak-proof connectors
- Double horn

Lighting

- 1 working light on the fuel tank
- 1 working lights on the boom
- 1 working lights on the cab

Operator environment

- Modern cab, 1 meter wide
- Safety glass

- Suspended cab (6 mounting points with rubber/fluid shock absorbing mountings)
- Windscreen with lockable opening
- "LCD" display
- Water and dust-proof membrane type controls
- Windscreen washer and wiper
- Adjustable heater
- Floor mat
- Sun visor
- Rear-view mirror and safety mirrors
- Self adjusting air conditioning
- Anti-theft device

Operator seat

- Air suspension
- Height and tilt adjustment
- Adjustable heat-rest
- Adjustable seat-back angle
- Adjustable arm-rests
- Reel-type safety belt

Equipment

- EMS (Extended Maintenance System) chrome pins with brush bushing throughout entire attachment except bucket
- Track guide (over full chassis length)
- Upper and lower undercovers
- LC undercarriage
- Sealed and lubricated track

OPTIONS

- Auxiliary hydraulic circuit
Possible options and combinations:
 - Hammer circuit with pedal control
 - 2nd auxiliary circuit for clamshell rotation, etc.
 - Dual-acting circuit (shears type)
 - Multi-purpose circuit (hammer or shears)
 - Multi-purpose circuit + 2nd circuit
- MULTI-FIT quick coupler

Standard and optional equipment shown can vary by country.

Worldwide Case Construction Equipment Contact Information

EUROPE/AFRICA/MIDDLE EAST:
Centre D'affaires EGB
5, Avenue Georges Bataille - BP 40401
60671 Le Plessis-belleville - FRANCE

NORTH AMERICA/MEXICO:
700 State Street
Racine, WI 53404 U.S.A.

LATIN AMERICA:
Av. General David Sarnoff 2237
32210 - 900 Contagem - MG
Belo Horizonte BRAZIL

ASIA PACIFIC:
Unit 1 - 1 Foundation Place - Prospect
New South Wales - 2148 AUSTRALIA

CHINA:
No. 29, Industrial Premises, No. 376,
De Bao Road, Waigaoqiao Ftz, Pudong,
SHANGHAI, 200131, P.R.C.

NOTE: Standard and optional fittings can vary according to the demands and specific regulations of each country. The illustrations may include optional rather than standard fittings - consult your Case dealer. Furthermore, CNH reserves the right to modify machine specifications without incurring any obligation relating to such changes.



Conforms to directive 98/37/CE

Case Construction Equipment

CNH UK Ltd.
Armstrong House
The Finningley Estate
Hayfield Lane
Doncaster
DN9 3XA
Fax +44 (0)1302 802126

www.casece.com

CASE