

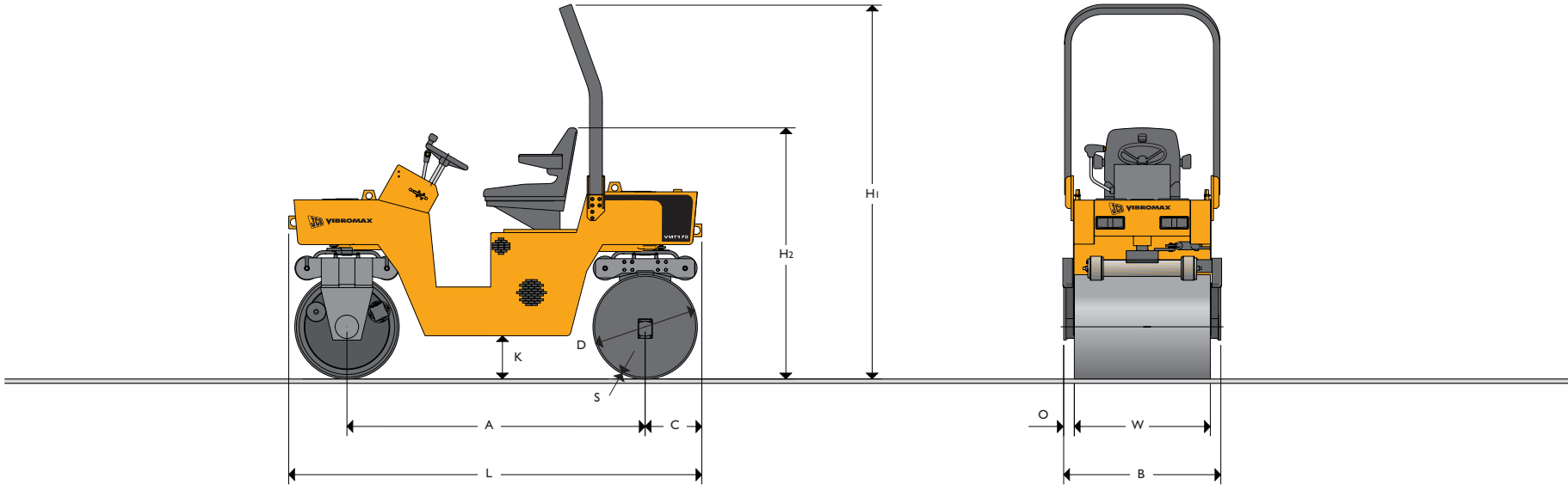

## JCB VIBROMAX – COMPACTION EQUIPMENT TANDEM VIBRATORY ROLLER VMT170



MAX. DRUM WIDTH: 850mm (33.5in)  
MAX. OPERATING WEIGHT: 1700kg (3748lb)



### STATIC DIMENSIONS

Dimensions in millimetres (in)	
A Wheelbase	1865 (73.4)
B Overall width	980 (38.6)
C Axle to rear face	354 (13.9)
D Drum thickness	650 (25.6)
H1 Total travel clearance	2400 (95.4)
H2 Height to top of seat	1570 (61.8)
K Ground clearance	270 (10.6)
L Total travel length	2580 (101.6)
O Overhang	70 (2.8)
S Drum thickness	10 (0.4)
W Drum width	850 (33.5)

### OPERATING DATA

Operating weight (CECE)	kg (lb)	1700 (3748)
Operating axle load front / rear	kg (lb)	800 (1764) / 900 (1984)
Linear load front / rear	kg/cm (lb/in)	9.4 (53) / 10.6 (59)
Exciter frequency	Hz (vpm)	50 (3000)
Nominal amplitude	mm (in)	0.5 (0.02)
Centrifugal force per drum	kN (lbf)	14 (3147)
Centrifugal force / drum width	N/cm (lbf/in)	165 (94)
Compaction depth up to	cm (in)	30 (11.8)
Working speed (forward / reverse) max.	km/h (mph)	6 (3.7)
Travel speed (forward / reverse) max.	km/h (mph)	14 (8.7)
Steering lock angle front / rear	degrees	±30 / ±20
Vertical oscillation	degrees	±5
<b>Drum offset right / left up to</b>	<b>mm (in)</b>	<b>550 (21.7)</b>
Inner turning radius	m (in)	1.56 (61.4)
Gradeability up to	degrees (%)	19 (34)
Tyres front		205/60R15



## JCB VIBROMAX – COMPACTION EQUIPMENT TANDEM VIBRATORY ROLLER VMT170



### ENGINE

Two-cylinder, air-cooled, four-stroke diesel engine.

Make	HATZ	
Model	2 G 40	
Piston displacement	cm <sup>3</sup>	997
Performance – DIN 6271	kW (hp)	14.4 (19.6)
Operating speed	min <sup>-1</sup> (rpm)	2900 (2900)
Starting device	Electric motor	
Air cleaner	Dry cartridge	
Fuel filter	Cartridge	
Fuel consumption	l/h	2.88

### PROPULSION

Hydrostatic with variable displacement pump and fixed displacement motors with direct drive to both drums = double drum drive.

### EXCITER DRIVE

Electrically controlled hydrostatic direct drive on both drums for double vibration and simple vibration on rear drum only.

### EXCITER

Single-shaft circular exciter.

### STEERING SYSTEM

Servo-assisted double yoke steering with drum offset and oscillation facility front and rear.

### SERVICE CAPACITIES

Fuel	litres (US gal)	30 (7.9)
Engine oil (engine)	litres (US gal)	3 (0.8)
Engine oil (exciter)	litres (US gal)	0.15 (0.04)
Hydraulic oil	litres (US gal)	30 (7.9)
Sprinkler water, rear	litres (US gal)	80 (21.1)

### BRAKING SYSTEM

<b>Service brake:</b>	Hydrostatic propulsion system.
<b>Parking brake:</b>	Hydraulically released multi-disk brake on rear drum (CE-version: on both drums).
<b>Safety brake:</b>	Hydro-mechanical (CE-version).

### ELECTRICAL SYSTEM

Voltage	V	12
Battery capacity	Ah	66
Alternator	V (A)	14 (max. 21)

### INDICATORS AND SWITCHES

Fuel, battery charging current, starter lock, vibration, sprinkler system, parking brake, hour meter, engine oil pressure.



JCB Vibromax Compaction Equipment GmbH, PO Box 230149, 40087 Düsseldorf, Germany, Erkrather Straße 343, 40231 Düsseldorf, Germany. Tel: +49 (0) 2 11 - 9 86 63. Fax: +49 (0) 2 11 - 9 86 65 55. Web: <http://www.jcbvibromax.de>

JCB Vibromax America Inc, 2823 Carlisle-Avenue, Racine, WI, 53404, USA. Tel: +1 262-637-8111. Fax: +1 262-637-8211.

JCB Vibromax Singapore, Representative Office, 72 Pasir Ris Heights, Singapore 519279. Tel: +65 6583 8297. Tel: +65 6583 8301.

JCB cares for the environment. This paper has been produced without the use of elemental chlorine chemicals in the bleaching process.

JCB reserves the right to change specifications without notice. Illustrations shown may include optional equipment and accessories. The JCB logo is a registered trademark of J C Bamford Excavators Ltd.



9999/5143 11/05 Issue 1

A Product  
of Hard Work