

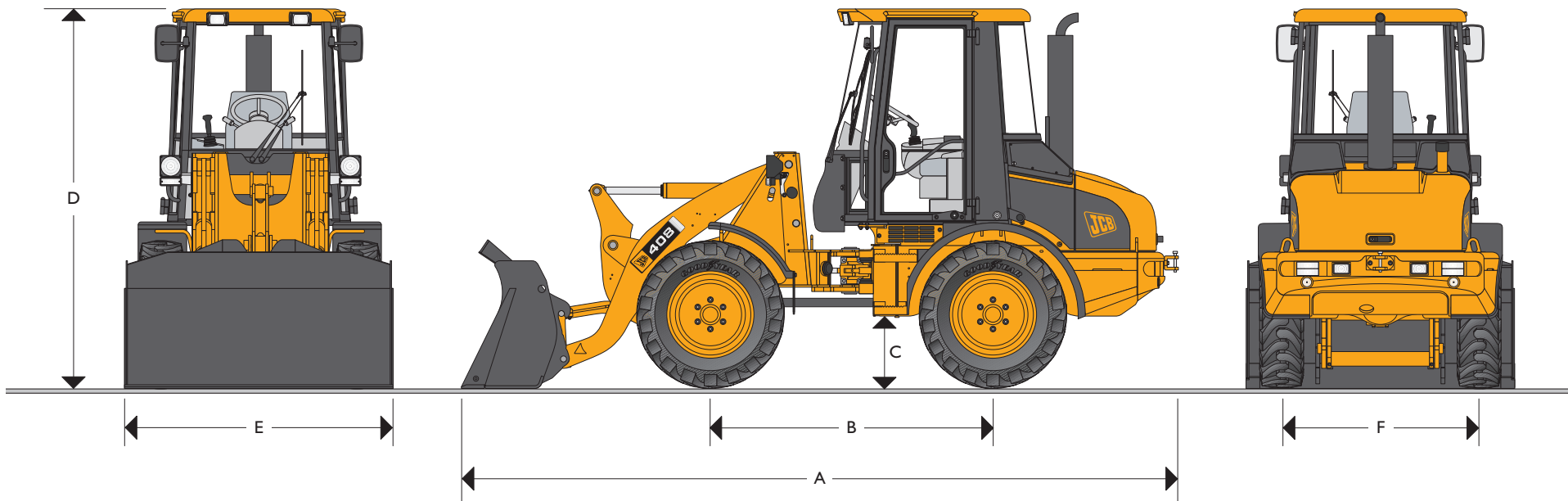

# JCB WHEELED LOADING SHOVEL | 408ZX



MAX. ENGINE POWER: 56kW (75hp)  
 MAX. OPERATING WEIGHT: 4840kg (10667lb)  
 MAX. LOADER CAPACITY: 0.8m<sup>3</sup> (1.0yd<sup>3</sup>)



## STATIC DIMENSIONS

	m (ft-in)		kg (lb)	
<b>A</b> Overall length with standard shovel	5.00 (16-5)	Front axle weight*	1880 (4144)	
<b>B</b> Wheel base	2.00 (6-7)	Rear axle weight*	2960 (6524)	
<b>C</b> Min. ground clearance	0.41 (1-5)	Operating weight (includes 80kg operator)	4840 (10667)	
<b>D</b> Height over cab	2.61 (8-7)	Inside radius	1.89 (6-3)	
<b>E</b> Max. shovel width	1.75 (5-9)	Maximum radius over shovel	4.01 (13-2)	
<b>F</b> Wheel track	1.38 (4-7)	Maximum radius over tyres	3.60 (11-10)	
		Articulation angle	degrees	±40°

\*Axle weight based on unloaded bucket in carry position.



# JCB WHEELED LOADING SHOVEL | 408ZX



## ENGINE

Type	4 cylinder diesel	
Make	JCB	
Model	1104C-44	
Capacity	ltr (in <sup>3</sup> )	4.4 (268.5)
Bore	mm (in)	105 (4.13)
Stroke	mm (in)	127 (5)
Aspiration	Naturally aspirated	
Cylinders	4	
<b>Power rating</b>		
Gross power to SAE J1995/ISO 14396	kW (HP) @ 2000rpm	56 (75)
Nett power to SAE J1349/EEC 80/1269	kW (HP) @ 2000rpm	50.2 (67)
<b>Torque rating</b>		
Gross torque	Nm (lbf ft) @ 1400rpm	302 (223)
Nett torque	Nm (lbf ft) @ 1400rpm	280 (207)

## TRANSMISSION

Type	Hydrostatic	
Make	Rexroth	
Model	A4VG/A6VM	
Low range	kph (mph)	6 (3.73)
High range	kph (mph)	20 (12.43)
High speed (option)	kph (mph)	30 (18.64)

## AXLES

Type	Portal design	
Make	JCB	
Model	PD55	
Overall axle ratio / Drop box ratio	16.2 / 2.19	
Chassis angle oscillation	degrees	±9°

## LOADER HYDRAULICS

Pump type	Gear	
Pump max. flow	l/min (UK gal/min)	66 (14.52)
Pump max. pressure	bar (lb/in <sup>2</sup> )	220 (3191)
<b>Hydraulic cycle times at full engine revs:</b>		
Arms raise (full bucket)	4.95	
Bucket dump (full bucket)	0.95	
Arms lower (empty bucket)	3.20	
Total cycle	9.10	

## SERVICE FILL CAPACITIES

	litres (UK gal)
Hydraulic and transmission system	85 (18.7)
Fuel tank	100 (22)
Engine oil sump	9.4 (1.88)
Axle oil (front)	9.5 (2.09)
Axle oil (rear)	10.5 (2.31)
Engine coolant system	15.5 (3.41)

## ELECTRICAL SYSTEM

System voltage	Volt	12
Alternator output	Amp hour	75
Battery capacity	Amp hour	106

## STANDARD EQUIPMENT

**Loader:** Single lever joystick servo control; Parallel lift geometry; Z-bar geometry; Quickhitch (hydraulic pin locking).

**Engine:** 4 cylinder water cooled diesel engine; single stage cyclonic engine air filter; Aluminised steel exhaust stack/silencer; Single bowl fuel filter; Fan guards.

**Transmission:** Two position electric switch; Neutral start; Disconnect on footbrake (inching capability); Directional control on column or servo control lever.

**Axles:** Torque proportioning differentials; JCB Portal design for added ground clearance.

**Brakes:** Parking brake on transmission output shaft; Additional braking from hydrostatic system.

**Electrical:** Road lights front and rear; Reverse alarm and lights; 75 Amp alternator.

**Hydraulics:** Gear pump with priority steer; Emergency steer back up; 3 spool loader circuit.

**Cab:** ROPS/FOPS safety structure; Fully adjustable seat; Interior light; Adjustable steering column; Safety glass; Electronic monitoring with warning panel; Front and rear screen wash/wipe; 3 speed heater fan with replaceable filters; Optional analogue gauges; LH and RH opening doors; Over centre handbrake with catch; Radio aperture; Single lever joystick servo control; Laminated screen; Loader control isolator; Front and rear work lights; Door ajar and lock back system.

**Bodywork:** Front and rear fenders; Side and rear access panels; Fixed bottom steps; Full width rear counterweight; Recovery hitch; Lifting lugs

## OPTIONAL EQUIPMENT

Limited slip differential axles front/rear; Air conditioning; Turbo 2 pre cleaner; 3 HBCV; Sealed alternator; Reversible fan; Epoxy coated cooling pack; Smooth ride system; Air suspension seat; Creep speed; 4th spool auxiliary circuit; Instrument pack; Front and rear working lights; Storage box; Shovel level indicator; Chaff guard; Forward/reverse on servo control lever; Manual controls; Fire extinguisher; Face level fan; Radio installation; Reverse alarm; Rotating beacon; Adjustable steering column; Reversing lights and rear fog lights; Sun visor; Engine sump kit; Biodegradable oil.



# JCB WHEELED LOADING SHOVEL | 408ZX



## LOADER DIMENSIONS

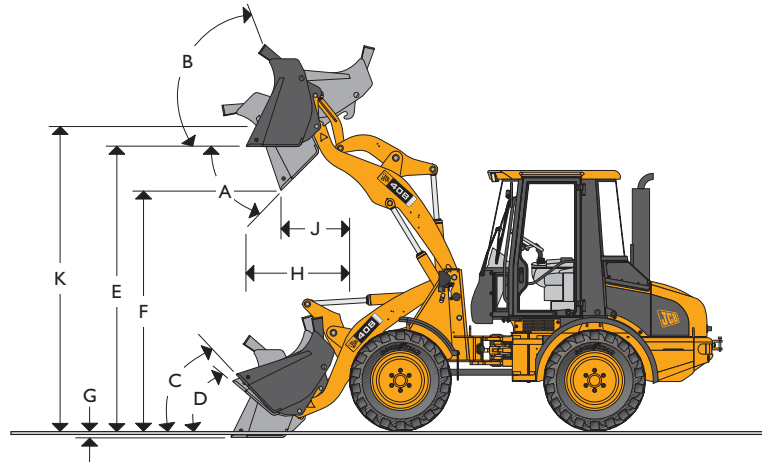

## LOADER DIMENSIONS

Loader dimensions: assumes fitment of 12.5x20 tyres.

Bucket mounting		Quickhitch (Zet)
Bucket type		General purpose
Bucket capacity (heaped)	m <sup>3</sup> (yd <sup>3</sup> )	0.8 (1.0)
Bucket capacity (struck)	m <sup>3</sup> (yd <sup>3</sup> )	0.67 (0.9)
Bucket equipment		Teeth or toeplate
Bucket width	mm (ft-in)	1900 (6-3)
Bucket weight without wear parts	kg (lb)	298 (657)
Max. material density	kg/m <sup>3</sup> (lb/yd <sup>3</sup> )	1800
Tipping load straight	kg (lb)	3390 (7472)
Tipping load full turn	kg (lb)	2900 (6392)
Payload 50%	kg (lb)	1450 (3196)
Max. tearout force	kN (lb)	41.7 (9375)
<b>A</b> Max. dump angle	degrees	45°
<b>B</b> Roll back angle at full height	degrees	69°
<b>C</b> Roll back at carry	degrees	52°
<b>D</b> Roll back at ground level	degrees	47°
<b>E</b> Load over height	mm (ft-in)	2944 (9-8)
<b>F</b> Dump height (45° dump)	mm (ft-in)	2517 (8-4)
<b>G</b> Dig depth	mm (ft-in)	66 (0-3)
<b>H</b> Max. reach (45° dump)	mm (ft-in)	612 (2-1)
<b>J</b> Reach at dump height	mm (ft-in)	612 (2-1)
<b>K</b> Max. pin height	mm (ft-in)	3142 (10-4)

## PALLET FORK DIMENSIONS

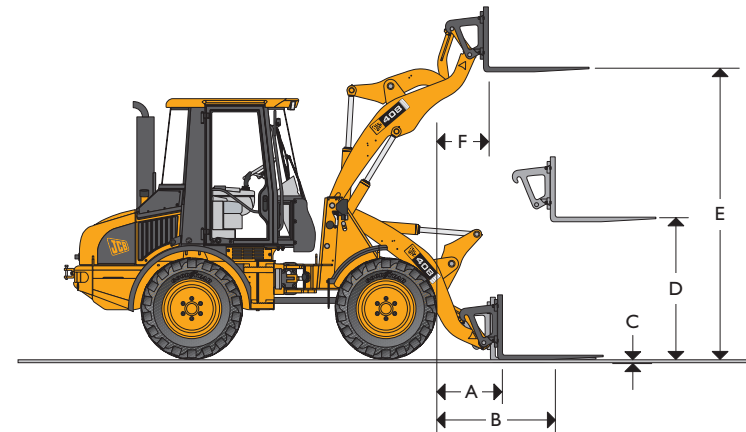

## PALLET FORK DIMENSIONS

Loader dimensions: assumes fitment of 12.5x20 tyres.

		mm (ft-in)
Fork carriage width		1343 (4-5)
Length of tines		1200 (4-0)
<b>A</b> Reach at ground level		701 (2-4)
<b>B</b> Max. reach arms horizontal		1214 (4-0)
<b>C</b> Below ground level		34 (0-2)
<b>D</b> Height arms horizontal		1420 (4-8)
<b>E</b> Max. height		3021 (9-11)
<b>F</b> Reach at max. height		473 (1-7)
Full turn tipping load (500mm load centres)	kg (lb)	2020 (4452)
Operating load (60%)	kg (lb)	1212 (2671)
Operating load (80%)	kg (lb)	1616 (3562)



## A GLOBAL COMMITMENT TO QUALITY

JCB's total commitment to its products and customers has helped it grow from a one-man business into Britain's largest privately owned manufacturer of backhoe loaders, crawler excavators, wheeled excavators, telescopic handlers, wheeled loaders, dump trucks, rough terrain fork lifts, industrial fork lifts, mini/midi excavators, skid steer loaders and tractors.

By making constant and massive investments in the latest production technology, the JCB factories have become some of the most advanced in Europe.

By leading the field in innovative research and design, extensive testing and stringent quality control, JCB machines have become renowned all over the world for performance, value and reliability.

And with a global sales and service network of over 400 distributors and agents, the company exports over 70% of its production to all five continents.

Through setting the standards by which others are judged, JCB has become one of Britain's most impressive success stories.

