

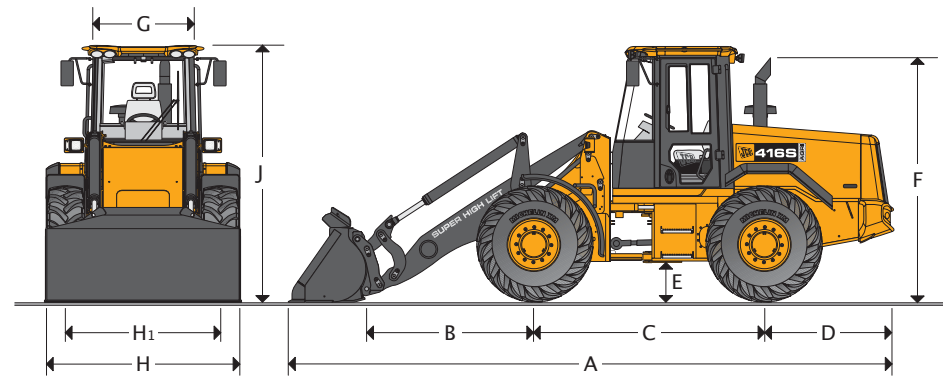

# JCB WHEELED LOADING SHOVEL | 416S

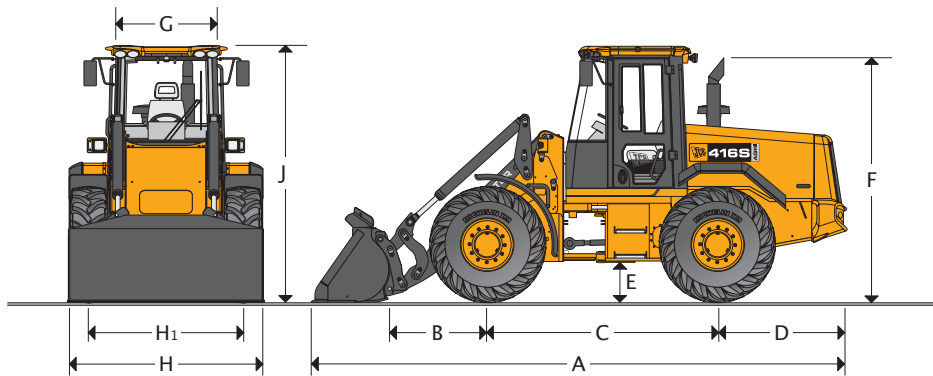

MAX. ENGINE POWER: 119kW (160hp)  
 MAX. OPERATING WEIGHT: 10173 kg (22344 lb)  
 MAX. LOADER CAPACITY: 1.7m<sup>3</sup> (2.2yd<sup>3</sup>)



## DIMENSIONS – Standard height arm

		mm (ft-in)
A	Overall length	6366 (20-11)
B	Axle to pivot pin	1180 (3-10)
C	Wheel base	2800 (9-2)
D	Axle to counterweight face	1598 (5-3)
E	Min. ground clearance	360 (1-2)
F	Height over exhaust	2843 (9-4)
G	Width over cab	1515 (5-0)
H	Width over tyres	2476 (8-1)
Hi	Wheel track	1980 (6-6)
J	Height over cab	2994 (9-10)
	Pin height (max.)	3618 (11-10)
	Overall operating height	4552 (14-11)
	Front axle weight	kg (lb) 4329 (9544)
	Rear axle weight	kg (lb) 4989 (10998)
	Total weight	kg (lb) 9318 (20543)
	Inside radius	2659 (8-9)
	Maximum radius	5410 (17-9)
	Articulation angle	±40°

Data based on machine equipped with a 1.4m<sup>3</sup> bucket and Michelin 500/70R24 XMCL tyres.

## DIMENSIONS – Super high lift arm

		mm (ft-in)
A	Overall length	7314 (24-0)
B	Axle to pivot pin	2143 (7-0)
C	Wheel base	2800 (9-2)
D	Axle to counterweight face	1598 (5-3)
E	Min. ground clearance	360 (1-2)
F	Height over exhaust	2840 (9-4)
G	Width over cab	1515 (5-0)
H	Width over tyres	2476 (8-1)
Hi	Wheel track	1980 (6-6)
J	Height over cab	2994 (9-9)
	Pin height (max.)	4464 (14-8)
	Overall operating height	5634 (17-9)
	Front axle weight	kg (lb) 4931 (10871)
	Rear axle weight	kg (lb) 4687 (10333)
	Total weight	kg (lb) 9618 (21204)
	Inside radius	2659 (8-9)
	Maximum radius	5770 (18-11)
	Articulation angle	±40°

Data based on machine equipped with a 1.4m<sup>3</sup> bucket and Michelin 500/70R24 XMCL tyres.



# JCB WHEELED LOADING SHOVEL | 416S



## LOADER

Widely spaced four ram geometry provides the combination of excellent visibility with high bucket torque characteristics throughout the working arc. The pin, bush and sealing design on all pivot points provide extended maintenance intervals.

## ENGINE

6-cylinder wastegated turbo-charged, liquid cooled, direct injection diesel. Air-to-air charge-air cooling ensure low emissions and provides minimum fuel consumption. A remote sump oil drain facility simplifies servicing.

Type	4 stroke direct injection	
Model	Cummins QSB	
Capacity	litres (in <sup>3</sup> )	6.7 (409)
Bore	mm (in)	107 (4.2)
Stroke	mm (in)	124 (4.9)
Aspiration	Turbo charged	
Cylinders	6	
Max gross power to SAE J1995/ISO 14396	kW (hp) @ 2000rpm	123 (165)
Rated gross power to SAE J1995/ISO 14396	kW (hp) @ 2200rpm	119 (160)
Nett power to SAE J1349/EEC 80/1269	kW (hp) @ 2200rpm	116 (156)
Max torque	Nm (lb.ft) @ 1400rpm	540 (732)

Emissions standards:- US EPA Tier 3, CARB Tier 3, EU Stage III.

## TRANSMISSION

4 wheel drive, automatic smooth shift transmission electrically operated selector and gear change incorporating a speed inhibitor and modulation for smooth, responsive on-the-move direction and ratio changes. Single stage integral torque converter 6 forward and 3 reverse gears.

Type	Smooth shift powershift		
Make & model	ZF 6WG 160		
Torque converter stall ratio	2.3 : 1		
<b>Speeds for 500/70R24 XMCL tyres</b>		<b>Forward</b>	<b>Reverse</b>
1st gear	kph (mph)	5.2 (3.2)	5.4 (3.4)
2nd gear	kph (mph)	7.9 (4.9)	12.4 (7.7)
3rd gear	kph (mph)	12.2 (7.6)	26.8 (16.7)
4th gear	kph (mph)	18.3 (11.4)	–
5th gear	kph (mph)	25.4 (15.8)	–
6th gear	kph (mph)	38.0 (23.6)	–
<b>Speeds for 620/70R26 XM27 tyres</b>		<b>Forward</b>	<b>Reverse</b>
1st gear	kph (mph)	6.0 (3.7)	6.1 (3.8)
2nd gear	kph (mph)	9.1 (5.6)	14.2 (8.8)
3rd gear	kph (mph)	14.0 (8.7)	30.7 (19.1)
4th gear	kph (mph)	21.0 (13.0)	–
5th gear	kph (mph)	29.1 (18.0)	–
6th gear	kph (mph)	43.5 (27.0)	–

## AXLES

Type	Limited slip differentials with epicyclic hub reduction
Make & model	JCB PD90
Overall axle ratio	20.18 : 1
Rear axle oscillation	25°

## STEERING

Priority steer hydraulic system with emergency steering. Piston pump meters flow through steer valve @ 220 bar (3190 lb/in<sup>2</sup>) to provide smooth low effort response. Steering angle  $\pm 40^\circ$ . Steer rams located high in the chassis fabrication to provide protection from damage. Adjustable steering column.

## BRAKES

Hydraulic power braking on all wheels, operating pressure 40 bar (580psi). Dual circuit with accumulator back-up provide maximum safety under all conditions. In-board mounted, oil immersed, multi-plate disc brakes with organic brake linings are environmentally acceptable. Parking brake, mechanical disc type operating on transmission output shaft.

## TYRES

A variety of tyre options are available including: 175-25 SGL (L2). 175R25 XLTA (L2). 175R25 XHA (L3). 175R25 XSNOWPLUS (L2). 20.5R25 XHA (L3). 500/70R24 XMCL. 620/70R26 XM27.

## LOADER HYDRAULICS

Variable displacement piston pump feeds a "load sensing" system providing a fuel efficient and responsive distribution of power as required. Main services are servo actuated from a single lever (joystick) loader control. Auxiliary circuits controlled via additional lever or joystick mounted electrical buttons. Accumulator back-up is available to control loader in the event of loss of pump pressure.

Pump type	Variable displacement piston pump	
Pump max. flow	l/min (UK gal/min)	220 (49)
Pump max. pressure	bar (lb/in <sup>2</sup> )	230 (3335)
<b>Hydraulic cycle times at full engine revs</b>		<b>seconds</b>
Arms raise (full bucket)		4.6
Bucket dump (full bucket)		1.4
Arms lower (empty bucket)		3.0
Total cycle		9.0

<b>Ram dimensions</b>	<b>Bore</b>	<b>Rod</b>	<b>Closed centres</b>	<b>Stroke</b>
Bucket ram x2	mm (in)	100 (3.9)	60 (2.4)	1598 (62.9)
Lift ram x2	mm (in)	100 (3.9)	60 (2.4)	1158 (45.6)
Steer ram x2	mm (in)	70 (2.8)	40 (1.6)	625 (24.6)
				312 (12.3)



# JCB WHEELED LOADING SHOVEL | 416S



## ELECTRICAL SYSTEM

24 volt negative ground system, 70 Amp alternator with 2 x 126 Amp hour low maintenance batteries. Isolator located in rear of machine. Ignition key start/stop and pre-heat cold start. Primary fuse box. Other electrical equipment includes quartz halogen, twin filament working lights, front/rear wash/wipe, heated rear screen, full road going lights, clock, gauge and warning light monitoring. Connectors to IP67 standard.

System voltage	Volt	24
Alternator output	Amp	70
Battery capacity	Amp hour	2 x 126

## CAB

Resiliently mounted ROPS/FOPS structure (tested in accordance with ISO 3471-1 : 1986 / ISO 3449 : 1984). De-luxe operator environment combines ergonomically located controls with a high level of appointment and low internal noise levels. Entry/exit is via large rear hinged door and anti-slip steps. Excellent forward visibility is provided by a 3 section curved, laminated windscreen and low waistline. Extensive instrumentation includes electronic monitoring panel and display (EMS). Heating / ventilation provides balanced and filtered air distribution throughout the cab via a powerful 11 kW capacity heater. The unitary construction allows easy sealing and prevents ingress of dust. A transmission lock on the selector prevents inadvertent engagement and the loader controls can be isolated for safe road travel.

Noise level measured in accordance with 86/662/EEC, amendment 95/27/EC

Interior pressure level : 74 Lp (A)  
Exterior power level : 105 Lw (A)

## ATTACHMENTS

An extensive range of attachments is available to users, covering the job requirements.

## SERVICE FILL CAPACITIES

	litres (UK gal)
Hydraulic system	130 (28.6)
Fuel tank	140 (30.8)
Engine oil sump	14 (3.1)
Transmission oil system	27.5 (6.1)
Axle oil (front)	23 (5.1)
Axle oil (rear)	23 (5.1)
Engine coolant system	21.5 (4.7)

## STANDARD EQUIPMENT

**Loader:** Bucket reset mechanism, loader arm kickout mechanism, loader control isolator; single lever servo control, high torque geometry combines with excellent visibility between the arms.

**Engine:** Air cleaner – 2 stage dry type – cyclonic with primary and safety elements, stainless steel silencer and exhaust stack, sedimenter; twin bowl fuel filters, fan guards.

**Transmission:** Single lever shift control, speed inhibitor; neutral start, disconnect on footbrake and loader lever, disconnect isolator switch, direction changes and kickdown on gear selector and loader control lever.

**Axles:** Limited slip differentials, front and rear, epicyclic wheel hub reduction, fixed front, oscillating rear.

**Brakes:** Multi-plate wet disc brakes, organic linings, dual circuit hydraulic power assisted. Parking disc brake on transmission output shaft.

**Hydraulics:** Piston pump with priority steer, emergency steer back-up, 2 spool loader circuit with accumulator support, 3rd spool auxiliary hydraulic circuit as standard. Hydraulic tank located in the rear chassis fabrication.

**Steering:** Adjustable steering column, "soft feel" steering wheel 5 turns lock to lock, resilient stops on max lock.

**Cab:** ROPS/FOPS safety structure, cigar lighter, ashtray, interior reading light, centre mounted master warning light. Electronic monitoring panel with LCD message display. Two speed intermittent front windscreen wipe/wash and self park, single speed rear windscreen wipe/wash and self park. 3 speed heater/demisting with replaceable air filter, LH and RH opening windows, sun visor; sun blind, internal rear view mirror; heated external mirrors, adjustable suspension seat with belt and headrest, operator storage facilities, laminated windscreen, heated rear screen, loader control isolator; horn, fire extinguisher, 24V to 12V in cab converter.

**Electrical:** Road lights front and rear, parking lights, front and rear working lights, reverse alarm and light, rear fog light, battery isolator, radio wiring and speakers, 70 amp alternator; rotating beacon.

**Bodywork:** Front and rear fenders, side and rear access panels, flexible bottom step, full width rear counterweight, recovery hitch, lifting lugs.

## OPTIONAL EQUIPMENT

Super high lift arms, auxiliary 4th spool hydraulic service, air conditioning, turbo 2 pre-cleaner; visibowl pre-cleaner, tooth guard, replaceable bucket wearparts, epoxy coated radiator/coolers, stainless steel brake pipes, Smooth ride system (SRS), hydraulic quickhitch, reversing camera (colour), auto greasing system, auxiliary control buttons on joystick, multi lever controls, front chassis apron mat, bolt on 110L (24.2 UK gal) auxiliary fuel tank, hydraulic tow hitch, 12V or 24V trailer electrics, trailer braking.



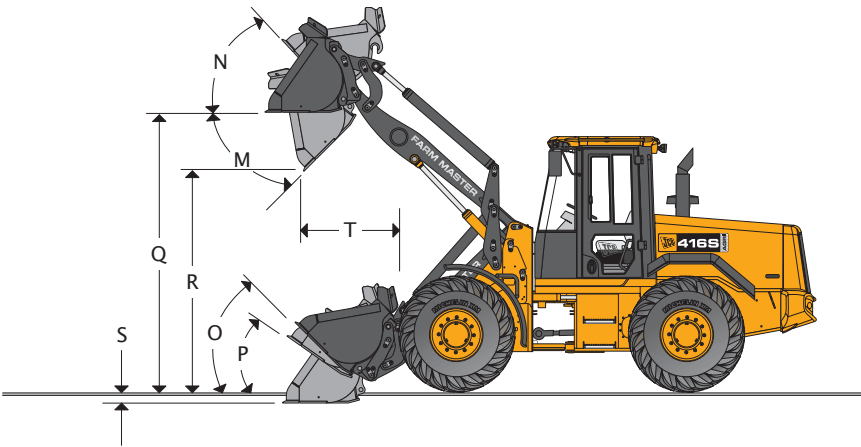

# JCB WHEELED LOADING SHOVEL | 416S



## CHANGES TO OPERATING PERFORMANCE AND DIMENSIONS

Tyre size	Manufacturer	Type	Rating	Op. weight kg (lb)	Tipping loads			Dimensions	
					Straight kg (lb)	Full turn kg (lb)	Vertical mm (in)	Width mm (in)	
620/70 R 26 (radial)	Michelin	XM27		+160 (+353)	+98 (+217)	+95 (+210)	+91 (+3.6)	+305 (+12)	
17.5 - 25 (crossply)	Firestone		L2	-108 (-238)	-66 (-146)	-64 (-142)	-11 (-0.433)	+10 (+0.394)	
17.5 - 25 (crossply)	Goodyear	SGL	L2	-128 (-282)	-78 (-173)	-76 (-168)	-11 (-0.433)	+10 (+0.394)	
17.5 R 25 (radial)	Michelin	XTLA	L2	-52 (-163)	-32 (-70)	-31 (-69)	-11 (-0.433)	+10 (+0.394)	

## DIMENSIONS – Standard height arm

									
		Direct	Direct	Direct	Direct	Quickhitch	Quickhitch	Quickhitch	Quickhitch
		General purpose	General purpose	General purpose	General purpose	General purpose	General purpose	General purpose	General purpose
<b>Loader dimensions: assumes fitment of Michelin 500/70R24 XMCL tyres.</b>									
Bucket mounting									
Bucket type		General purpose	General purpose	General purpose	General purpose	General purpose	General purpose	General purpose	General purpose
Bucket capacity (heaped)	m <sup>3</sup> (yd <sup>3</sup> )	1.4 (1.8)	1.6 (2.1)	1.5 (2.0)	1.7 (2.2)	1.4 (1.8)	1.6 (2.1)	1.5 (2.0)	1.7 (2.2)
Bucket wearparts		Tipped teeth	Tipped teeth	Reversible toeplate	Reversible toeplate	Tipped teeth	Tipped teeth	Reversible toeplate	Reversible toeplate
Bucket capacity (struck)	m <sup>3</sup> (yd <sup>3</sup> )	1.180 (1.542)	1.362 (1.780)	1.180 (1.542)	1.362 (1.780)	1.180 (1.542)	1.362 (1.780)	1.180 (1.542)	1.362 (1.780)
Bucket width	mm (ft-in)	2400 (7-10)	2400 (7-10)	2400 (7-10)	2400 (7-10)	2400 (7-10)	2400 (7-10)	2400 (7-10)	2400 (7-10)
Bucket weight with wearparts	kg (lb)	658 (1448)	698 (1536)	680 (1496)	720 (1584)	643 (1415)	683 (1503)	665 (1463)	705 (1551)
Max. material density	kg/m <sup>3</sup> (lb/yd <sup>3</sup> )	2029 (4473)	1760 (3879)	1894 (4176)	1656 (3652)	1943 (4284)	1685 (3715)	1814 (3998)	1585 (3494)
Tipping load straight	kg (lb)	6651 (14664)	6596 (14542)	6651 (14664)	6596 (14542)	6396 (14102)	6342 (13982)	6396 (14102)	6342 (13982)
Tipping load full turn	kg (lb)	5680 (12523)	5632 (12417)	5680 (12523)	5632 (12417)	5441 (11995)	5391 (11884)	5441 (11995)	5391 (11884)
Payload	kg (lb)	2840 (6262)	2816 (6209)	2840 (6262)	2816 (6209)	2720 (5997)	2695 (5942)	2720 (5997)	2695 (5942)
Max. breakout force	kN (lb)	100.4 (22570)	92.3 (20749)	100.4 (22570)	92.3 (20749)	92.7 (20839)	85.6 (19243)	92.7 (20839)	85.6 (19243)
<b>M</b> Dump angle max.		50°	50°	50°	50°	50°	50°	50°	50°
<b>N</b> Roll back angle at full height		43°	43°	43°	43°	43°	43°	43°	43°
<b>O</b> Roll back at carry		49°	49°	49°	49°	49°	49°	49°	49°
<b>P</b> Roll back at ground level		43°	43°	43°	43°	43°	43°	43°	43°
<b>Q</b> Load over height	mm (ft-in)	3386 (11-1)	3386 (11-1)	3386 (11-1)	3386 (11-1)	3403 (11-2)	3403 (11-2)	3403 (11-2)	3403 (11-2)
<b>R</b> Dump height (45° dump)	mm (ft-in)	2588 (8-6)	2538 (8-4)	2710 (8-11)	2660 (8-9)	2554 (8-5)	2534 (8-4)	2676 (8-9)	2626 (8-7)
<b>S</b> Dig depth	mm (ft-in)	101 (0-4)	101 (0-4)	93 (0-4)	93 (0-4)	84 (0-3)	84 (0-3)	76 (0-3)	76 (0-3)
<b>T</b> Reach at dump height	mm (ft-in)	1050 (3-3)	1095 (3-7)	940 (3-1)	985 (3-3)	1105 (3-7)	1150 (3-9)	995 (3-3)	1040 (3-5)
Reach max. (45° dump)	mm (ft-in)	1559 (5-1)	1629 (5-4)	1449 (4-9)	1519 (5-0)	1624 (5-4)	1694 (5-7)	1514 (5-0)	1584 (5-2)
Operating weight (inc. 80kg operator and full fuel tank)	kg (lb)	9311 (20527)	9351 (20615)	9333 (20576)	9373 (20664)	9296 (20494)	9336 (20582)	9318 (20543)	9358 (20631)

Note: 1.0m<sup>3</sup> = 1.308yd<sup>3</sup> = 35.32ft<sup>3</sup>. 1kg = 2.205lb. 1kg/m<sup>3</sup> = 1.686lb/yd<sup>3</sup> = 0.062lb/ft<sup>3</sup>.





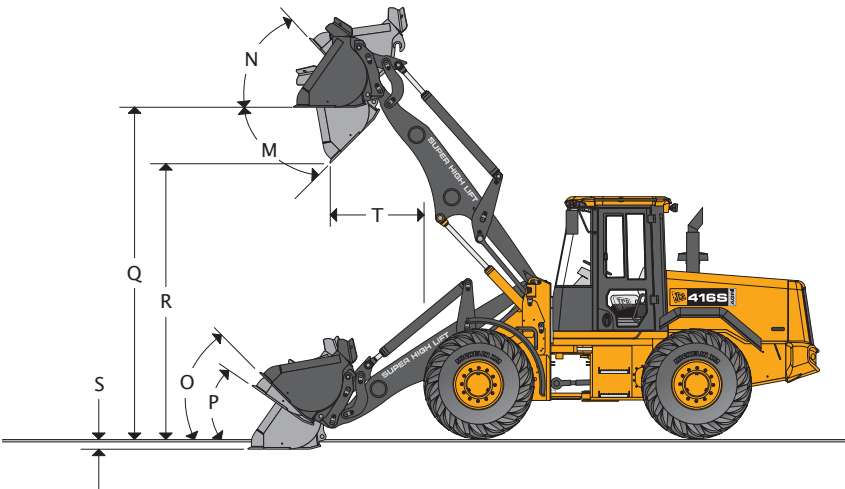



# JCB WHEELED LOADING SHOVEL | 416S

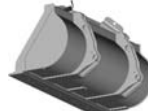

## CHANGES TO OPERATING PERFORMANCE AND DIMENSIONS

Tyre size	Manufacturer	Type	Rating	Op. weight kg (lb)	Tipping loads			Dimensions	
					Straight kg (lb)	Full turn kg (lb)	Vertical mm (in)	Width mm (in)	
620/70 R 26 (radial)	Michelin	XM27		+160 (+353)	+98 (+217)	+95 (+210)	+91 (+3.6)	+305 (+12)	
17.5 - 25 (crossply)	Firestone		L2	-108 (-238)	-66 (-146)	-64 (-142)	-11 (-0.433)	+10 (+0.394)	
17.5 - 25 (crossply)	Goodyear	SGL	L2	-128 (-282)	-78 (-173)	-76 (-168)	-11 (-0.433)	+10 (+0.394)	
17.5 R 25 (radial)	Michelin	XTLA	L2	-52 (-163)	-32 (-70)	-31 (-69)	-11 (-0.433)	+10 (+0.394)	

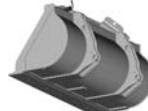
## DIMENSIONS – Super high lift arm

									
Loader dimensions: assumes fitment of Michelin 500/70R24 XMCL tyres.									
Bucket mounting		Direct	Direct	Direct	Direct	Quickhitch	Quickhitch	Quickhitch	Quickhitch
Bucket type		General purpose	General purpose	General purpose	General purpose	General purpose	General purpose	General purpose	General purpose
Bucket capacity (heaped)	m <sup>3</sup> (yd <sup>3</sup> )	1.4 (1.8)	1.6 (2.1)	1.5 (2.0)	1.7 (2.2)	1.4 (1.8)	1.6 (2.1)	1.5 (2.0)	1.7 (2.2)
Bucket wearparts		Tipped teeth	Tipped teeth	Reversible toeplate	Reversible toeplate	Tipped teeth	Tipped teeth	Reversible toeplate	Reversible toeplate
Bucket capacity (struck)	m <sup>3</sup> (yd <sup>3</sup> )	1.180 (1.542)	1.362 (1.780)	1.180 (1.542)	1.362 (1.780)	1.180 (1.542)	1.362 (1.780)	1.180 (1.542)	1.362 (1.780)
Bucket width	mm (ft-in)	2400 (7-10)	2400 (7-10)	2400 (7-10)	2400 (7-10)	2400 (7-10)	2400 (7-10)	2400 (7-10)	2400 (7-10)
Bucket weight with wearparts	kg (lb)	658 (1448)	698 (1536)	680 (1496)	720 (1584)	643 (1415)	683 (1503)	665 (1463)	705 (1551)
Max. material density	kg/m <sup>3</sup> (lb/yd <sup>3</sup> )	1406 (3099)	1220 (2689)	1313 (2894)	1149 (2532)	1333 (2939)	1156 (2548)	1333 (2939)	1087 (2397)
Tipping load straight	kg (lb)	4589 (10117)	4551 (10034)	4589 (10117)	4551 (10034)	4382 (9660)	4344 (9577)	4382 (9660)	4344 (9577)
Tipping load full turn	kg (lb)	3936 (8678)	3904 (8606)	3936 (8678)	3904 (8606)	3732 (8228)	3699 (8154)	3732 (8228)	3699 (8154)
Payload	kg (lb)	1968 (4339)	1952 (4303)	1968 (4339)	1952 (4303)	7866 (4114)	1849 (4077)	1866 (4114)	1849 (4077)
Max. breakout force	kN (lb)	101.4 (22794)	94.7 (21289)	101.4 (22794)	94.7 (21289)	95.1 (21378)	85.6 (19243)	95.1 (21378)	85.6 (19243)
<b>M</b> Dump angle max.		45°	45°	45°	45°	45°	45°	45°	45°
<b>N</b> Roll back angle at full height		47°	47°	47°	47°	47°	47°	47°	47°
<b>O</b> Roll back at carry		57.5°	57.5°	57.5°	57.5°	57.5°	57.5°	57.5°	57.5°
<b>P</b> Roll back at ground level		49°	49°	49°	49°	49°	49°	49°	49°
<b>Q</b> Load over height	mm (ft-in)	4239 (13-11)	4239 (13-11)	4239 (13-11)	4239 (13-11)	4256 (14-0)	4256 (14-0)	4256 (14-0)	4256 (14-0)
<b>R</b> Dump height (45° dump)	mm (ft-in)	3436 (11-3)	3386 (11-1)	3558 (11-8)	3508 (11-6)	3402 (11-2)	3382 (11-1)	3524 (11-7)	3474 (11-5)
<b>S</b> Dig depth	mm (ft-in)	142 (0-6)	142 (0-6)	134 (0-5)	134 (0-5)	125 (0-5)	125 (0-5)	117 (0-5)	117 (0-5)
<b>T</b> Reach at dump height	mm (ft-in)	1195 (3-11)	1240 (4-1)	1085 (3-7)	1130 (3-8)	1250 (4-1)	1295 (4-3)	1140 (3-9)	1185 (3-11)
Reach max. (45° dump)	mm (ft-in)	2415 (7-11)	2485 (8-2)	2305 (7-7)	2375 (7-10)	2480 (8-2)	2550 (8-4)	2370 (7-9)	2440 (8-0)
Operating weight (inc. 80kg operator and full fuel tank)	kg (lb)	9311 (20527)	9351 (20615)	9633 (21237)	9373 (20664)	9596 (21156)	9336 (20582)	9318 (20543)	9358 (20631)

Note: 1.0m<sup>3</sup> = 1.308yd<sup>3</sup> = 35.32ft<sup>3</sup>. 1kg = 2.205lb. 1kg/m<sup>3</sup> = 1.686lb/yd<sup>3</sup> = 0.062lb/ft<sup>3</sup>.



## FORK FRAME WITH FORKS

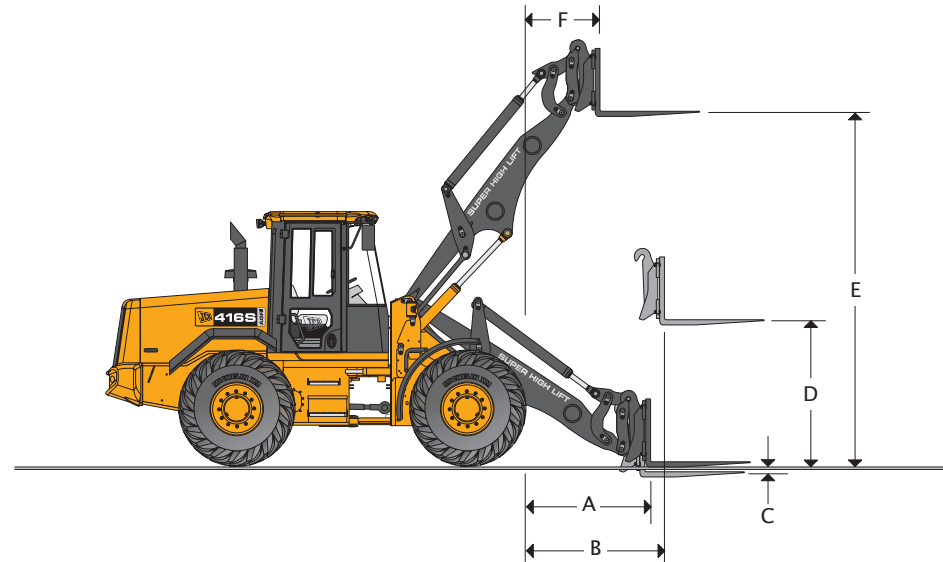
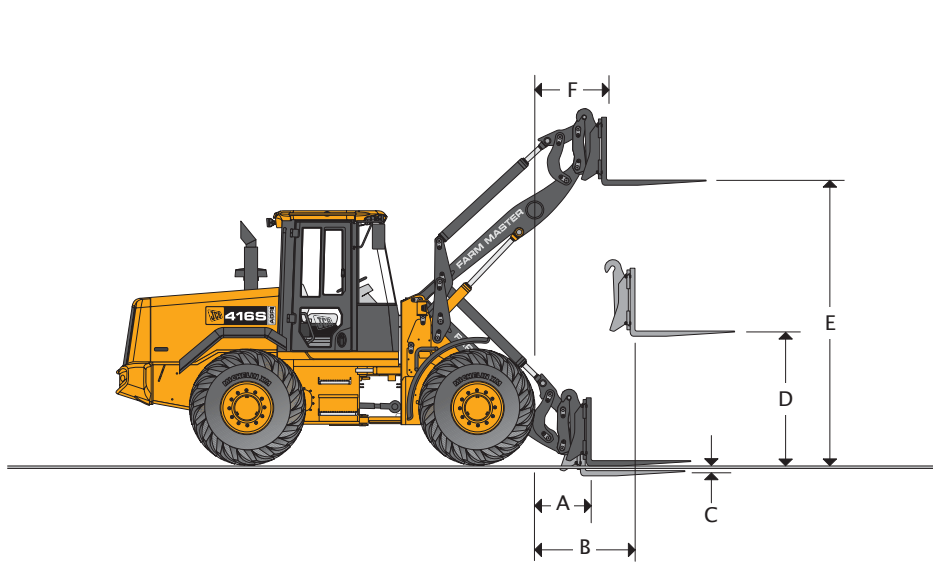

### LOADER DIMENSIONS – Standard height arm

		Parallel fork m (ft-in)	Roll back fork m (ft-in)
Fork carriage width		1500 (4-11)	1500 (4-11)
Length of tines		1220 (4-0)	1220 (4-0)
<b>A</b> Reach at ground level		666 (2-2)	673 (2-2)
<b>B</b> Reach at arms horizontal		1439 (4-9)	1446 (4-9)
<b>C</b> Below ground level		18 (0-1)	26 (0-1)
<b>D</b> Arms horizontal height		1781 (5-10)	1771 (5-10)
<b>E</b> Arms maximum height		3438 (11-3)	3428 (11-3)
<b>F</b> Reach at maximum height		803 (2-8)	810 (2-8)
Payload**	kg (lb)	3320 (7321)	3255 (7177)
Tipping load straight	kg (lb)	4865 (10728)	4770 (10518)
Tipping load full turn (40°)	kg (lb)	4150 (9151)	4069 (8972)
Attachment weight	kg (lb)	440 (968)	440 (968)

### LOADER DIMENSIONS – Super high lift arm

		Parallel fork m (ft-in)	Roll back fork m (ft-in)
Fork carriage width		1500 (4-11)	1500 (4-11)
Length of tines		1220 (4-0)	1220 (4-0)
<b>A</b> Reach at ground level		1527 (5-0)	1534 (5-0)
<b>B</b> Reach at arms horizontal		2114 (5-11)	2121 (7-0)
<b>C</b> Below ground level		51 (0-2)	61 (0-2)
<b>D</b> Arms horizontal height		1781 (5-10)	1771 (5-10)
<b>E</b> Arms maximum height		4297 (14-1)	4287 (14-1)
<b>F</b> Reach at maximum height		859 (2-10)	866 (2-10)
Payload**	kg (lb)	1771 (3905)	1736 (3828)
Tipping load straight	kg (lb)	3611 (7964)	3541 (7808)
Tipping load full turn (40°)	kg (lb)	2213 (4881)	2170 (4785)
Attachment weight	kg (lb)	440 (968)	440 (968)

\*\*At a centre of gravity distance of 500mm (1ft-8in). Based on 80% of full turn tipping load as defined by ISO 8313. Manual for spacings at 50mm increments. Fork section 100mm x 50mm (4 x 2 inch). Assumes the machine is fitted with Michelin 500/70R24 XMCL tyres.



# JCB WHEELED LOADING SHOVEL | 416S



## BUCKET SELECTOR

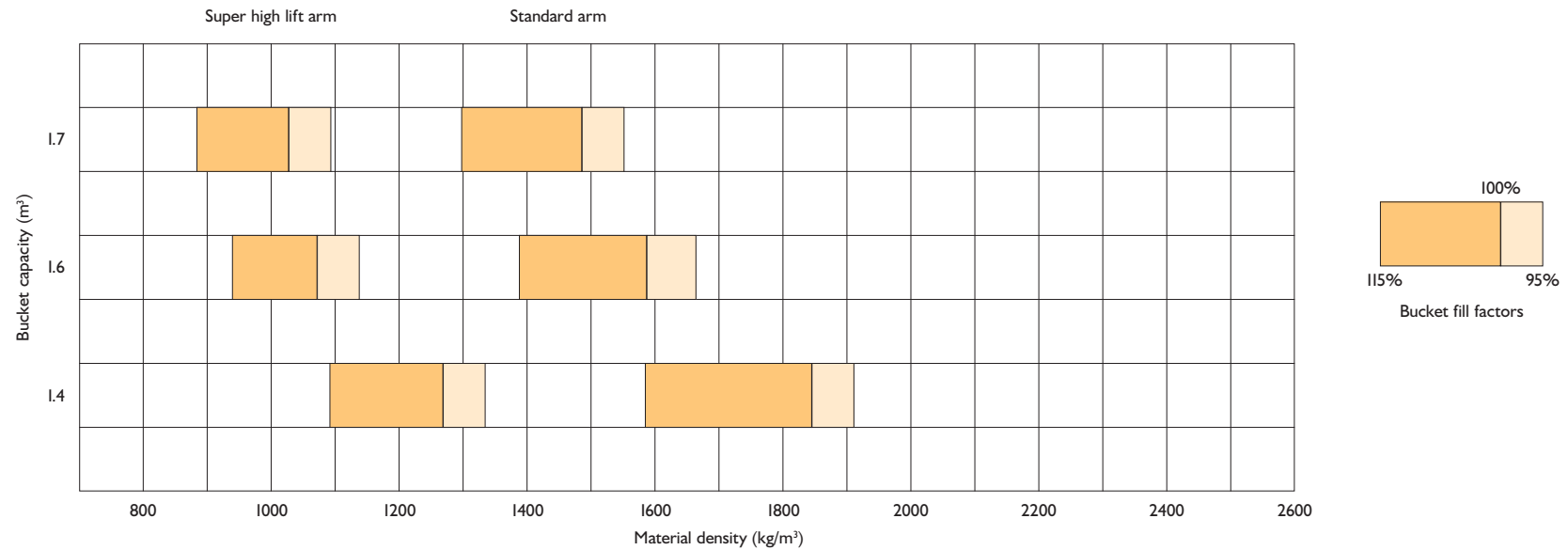

## BUCKET SELECTOR

Material	Loose density		Fill factor
	kg/m³	lb/yd³	%
Snow (fresh)	200	337	110
Peat (dry)	400	674	100
Sugar beet	530	894	100
Coke (loose)	570	961	85
Barley	600	1012	85
Petroleum coke	680	1146	85
Wheat	730	1231	85
Coal bituminous	765	1290	100
Fertiliser (mixed)	1030	1737	85
Coal anthracite	1046	1764	100
Earth (dry) (loose)	1150	1939	100
Nitrate fertiliser	1250	2180	85

Material	Loose density		Fill factor
	kg/m³	lb/yd³	%
Sodium chloride (dry) (salt)	1300	2192	85
Cement Portland	1440	2428	100
Limestone (crushed)	1530	2580	100
Sand (dry)	1550	2613	100
Asphalt	1600	2698	100
Gravel (dry)	1650	2782	85
Clay (wet)	1680	2832	110
Sand (wet)	1890	3187	110
Fire clay	2080	3507	100
Copper (concentrate)	2300	3878	85
Slate	2800	4721	100
Magnetite	3204	5402	100



## A GLOBAL COMMITMENT TO QUALITY

JCB's total commitment to its products and customers has helped it grow from a one-man business into Britain's largest privately owned manufacturer of backhoe loaders, crawler excavators, wheeled excavators, telescopic handlers, wheeled loaders, dump trucks, rough terrain fork lifts, industrial fork lifts, mini/midi excavators, skid steer loaders and tractors.

By making constant and massive investments in the latest production technology, the JCB factories have become some of the most advanced in Europe.

By leading the field in innovative research and design, extensive testing and stringent quality control, JCB machines have become renowned all over the world for performance, value and reliability.

And with a global sales and service network of over 400 distributors and agents, the company exports over 70% of its production to all five continents.

Through setting the standards by which others are judged, JCB has become one of Britain's most impressive success stories.

