

EN



Bobcat®

Operation & Maintenance Manual

T250

TURBO

T250

TURBO

HIGH FLOW

S/N 525613400 & Above
S/N 525712100 & Above

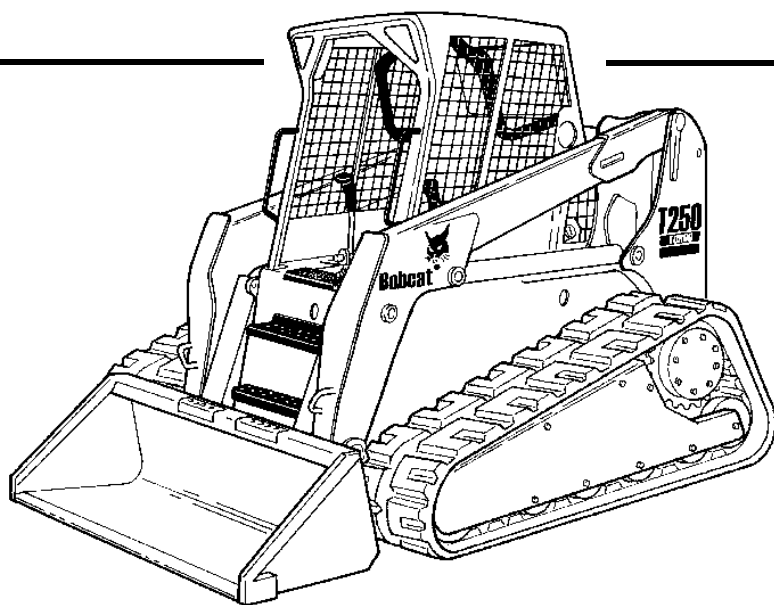

EQUIPPED WITH
BOBCAT INTERLOCK
CONTROL SYSTEM (BICS™)

6904182-EN (04-05)

An  Ingersoll Rand business

Printed in Europe

© Bobcat Europe 2005

OPERATOR SAFETY WARNINGS

WARNING

Operator must have instructions before running the machine. Untrained operators can cause injury or death.

W-2001-1285

Safety Alert Symbol: This symbol with a warning statement, means: "Warning, be alert! Your safety is involved!" Carefully read the message that follows.

CORRECT

B-10731a

Never use the loader without instructions. See machine signs (decals), Operation & Maintenance Manual and Handbook.

CORRECT

B-15570

Always use the seat bar and fasten seat belt snugly.
 Always keep feet on the foot pedals or footrests when operating loader.

CORRECT

B-15652

Never use loader without operator cab with ROPS and FOPS approval. Fasten your seat belt.

WRONG

B-15653

Never use loader as man lift or elevating device for personnel.

WRONG

B-15260

Do not use loader in atmosphere with explosive dust or gas or where exhaust can contact flammable material.

WRONG

B-15654

Never carry riders.
 Keep bystanders away from work area.

WRONG

B-15655

Always carry bucket or attachments as low as possible.
 Do not travel or turn with lift arms up.
 Load, unload and turn on flat level ground.

WRONG

B-15656

Never exceed rated operating capacity.

WRONG

B-15661

Never leave loader with engine running or with lift arms up.
 To park, engage parking brake and put attachment flat on the ground.

WRONG

B-15658

Never modify equipment.
 Use only attachments approved by Bobcat Company for this model loader.

SAFETY EQUIPMENT

The Bobcat loader must be equipped with safety items necessary for each job. Ask your dealer for information on the safe use of attachments and accessories.

1. **SEAT BELT:** Check belt fasteners and check for damaged webbing or buckle.
2. **SEAT BAR:** When up, it must lock the loader controls.
3. **OPERATOR CAB (ROPS and FOPS):** It must be on the loader with all fasteners tight.
4. **HANDBOOK:** Must be in the cab.
5. **SAFETY SIGNS (DECALS):** Replace if damaged.
6. **SAFETY TREADS:** Replace if damaged.
7. **GRAB HANDLES:** Replace if damaged.
8. **LIFT ARM SUPPORT DEVICE:** Replace if damaged.
9. **PARKING BRAKE**
10. **BOBCAT INTERLOCK CONTROL SYSTEM (BICS™)**

OSW10-1003

CONTENTS

FOREWORDIII
OPERATING INSTRUCTIONSOI-1
PREVENTIVE MAINTENANCEPM-1
SAFETY XI
SPECIFICATIONSSPEC-1
SYSTEM SETUP & ANALYSIS SA-1

REFERENCE INFORMATION

Write the correct information for YOUR Bobcat Loader in the spaces below. Always use these numbers when referring to your Bobcat loader.

Loader Serial Number _____
Engine Serial Number _____

NOTES:

YOUR BOBCAT® DEALER:

ADDRESS:

PHONE:



Bobcat Europe
J. Huysmanslaan 59
B-1651 LOT
Belgium

FOREWORD

SAFETY

OPERATING
INSTRUCTIONS

PREVENTIVE
MAINTENANCE

SYSTEM SETUP
& ANALYSIS

SPECIFICATIONS



Bobcat®

This Operation & Maintenance Manual was written to give the owner/operator instructions on the safe operation and maintenance of the Bobcat loader. **READ AND UNDERSTAND THIS OPERATION & MAINTENANCE MANUAL BEFORE OPERATING YOUR Bobcat loader.** If you have any questions, see your Bobcat dealer. This manual may illustrate options and accessories not installed on your loader.

BOBCAT COMPANY IS ISO 9001:2000 CERTIFIED V

DELIVERY REPORT VI

ENGINE SERIAL NUMBER VI

FEATURES, ACCESSORIES AND ATTACHMENTS VIII

 Attachments IX

 Buckets Available IX

 Options and Accessories VIII

 Standard Items VIII

LOADER SERIAL NUMBER VI

MACHINE IDENTIFICATION VII

MOTOR OIL V

REGULAR MAINTENANCE ITEMS V

SERIAL NUMBER LOCATIONS VI



Bobcat®

BOBCAT COMPANY IS ISO 9001:2000 CERTIFIED











ISO 9001:2000 is a set of international standards that control the processes and procedures which we use to design, develop, manufacture, distribute, and service Bobcat products.

British Standards Institute (**BSI**) is the Certified Registrar Bobcat chose to assess the Company’s compliance with the ISO 9001:2000 set of standards. The BSI registration certifies that the two Bobcat manufacturing plants and the Bobcat corporate offices (Gwinner, Bismarck & West Fargo) in North Dakota are in compliance with ISO 9001:2000. Only certified assessors, like BSI, can grant registrations.

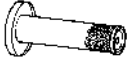
ISO 9001:2000 means that as a company we say what we do and do what we say. In other words, we have established procedures and policies, and we provide evidence that the procedures and policies are followed.

REGULAR MAINTENANCE ITEMS

	ENGINE OIL FILTER (6 Pack) 6665603		BATTERY 6665427
	FUEL FILTER 6667352		FLUID, Hydraulic/Hydrostatic 6903117 - (9,5 L) 6903118 - (19 L) 6903119 - (215 L)
	AIR FILTER, Outer 6666375		RADIATOR CAP 6733429
	AIR FILTER, Inner 6666376		PROPYLENE GLYCOL ANTI-FREEZE, Premixed [-37°C (-34°F)] 6724094
	HYDROSTATIC FILTER 6661248		PROPYLENE GLYCOL ANTI-FREEZE, Concentrate 6724354
	HYDROSTATIC FILTER, In-Line 6661807		

MOTOR OIL

6667299 SAE 15W40 CE/SG (12 L)	6724558 SAE 15W40 CE/SG (3,8 L)	6674294 SAE 15W40 CE/SG (9,5 L)
6657301 SAE 10W30 CE/SG (12 L)	6724557 SAE 10W30 CE/SG (3,8 L)	6674205 SAE 10W30 CE/SG (9,5 L)
6903109 - SAE 30W CE/SG (12 L)	6903110 - SAE 30W CE/SG (3,8 L)	6903111 - SAE 30W CE/SG (9,5 L)

SERIAL NUMBER LOCATIONS

Always use the serial number of the loader when requesting service information or when ordering parts. Early or later models (identification made by serial number) may use different parts, or it may be necessary to use a different procedure in doing a specific service operation.

Figure 1



LOADER SERIAL NUMBER

The loader serial number plate is located on the outside of the loader frame [Figure 1].

Explanation of loader Serial Number:

XXXX XXXXX

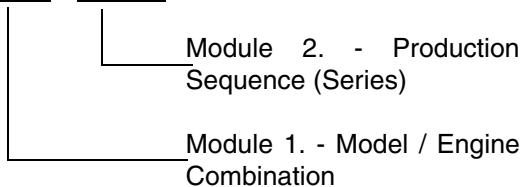

1. The four digit Model/Engine Combination Module number identifies the model number and engine combination.

2. The five digit Production Sequence Number identifies the order which the loader is produced.

ENGINE SERIAL NUMBER

Figure 2

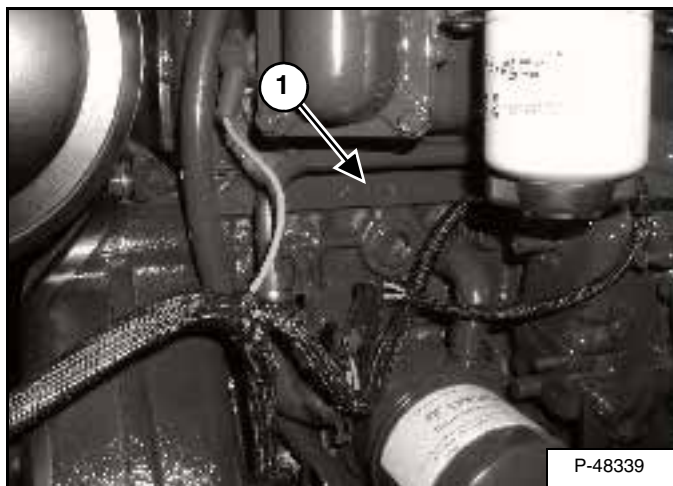

The engine serial number is located on the side of the engine (Item 1) [Figure 2] above the oil filter.

DELIVERY REPORT

Figure 3

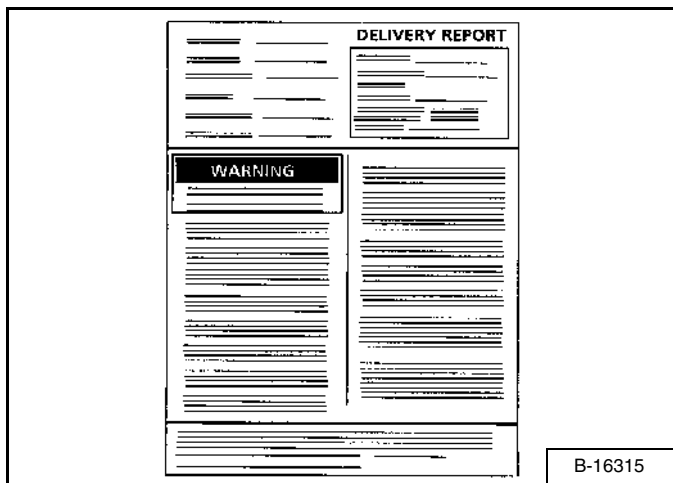

The delivery report must be filled out by the dealer and signed by the owner or operator when the Bobcat loader is delivered. An explanation of the form must be given to the owner. Make sure it is filled out completely [Figure 3].

MACHINE IDENTIFICATION

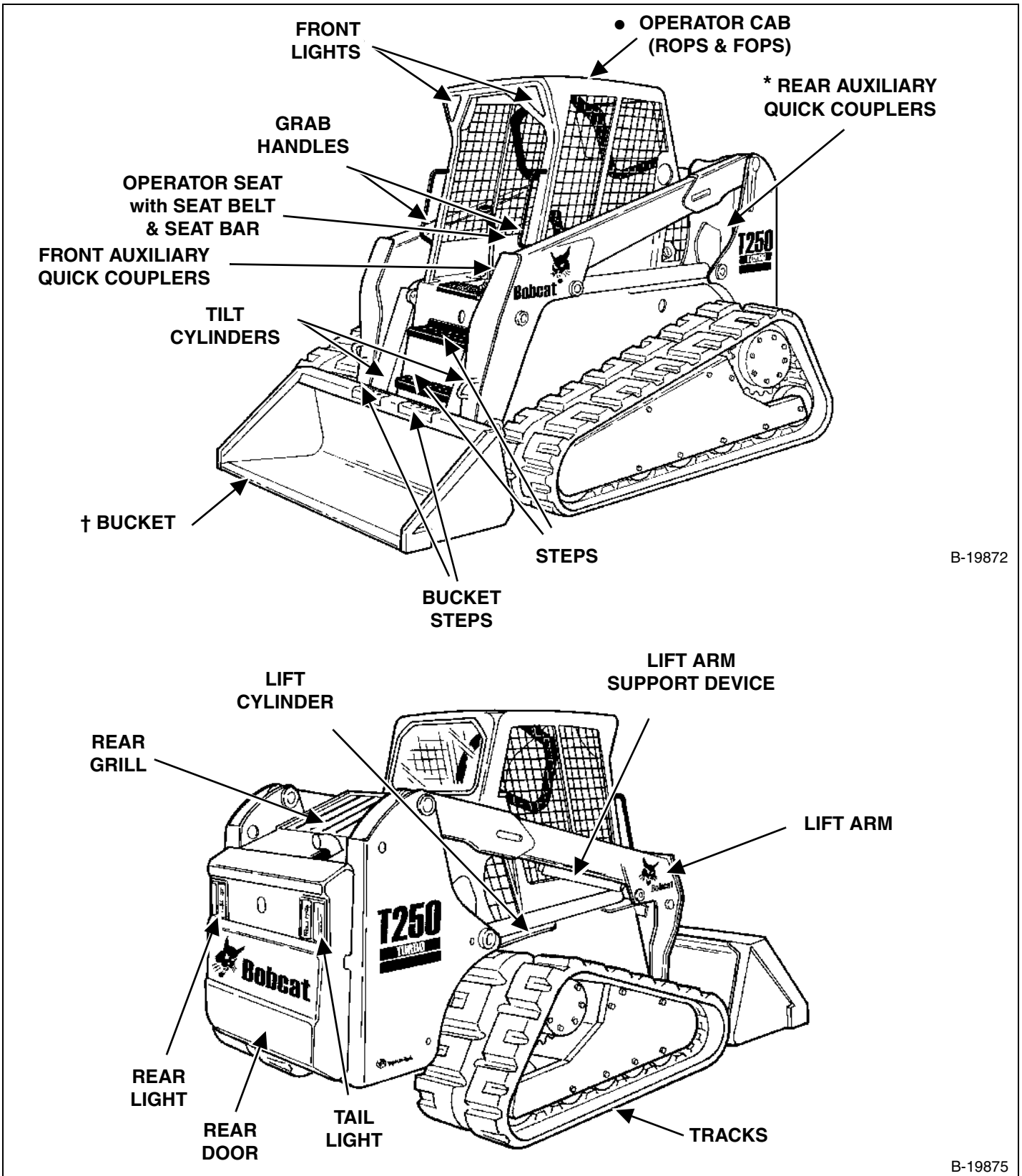

B-19872

B-19875

* Option or Field Accessory

† Many buckets and other attachments are available.

● ROPS, FOPS - Roll Over Protective Structure per SAE J1040 and ISO 3471, and Falling Object Protective Structure ISO 3449, Level I. Level II is available.

FEATURES, ACCESSORIES AND ATTACHMENTS

Standard Items

Model T250 Bobcat loaders are equipped with the following standard items:

- Adjustable suspension seat
- Bobcat Interlock Control System (BICS)
- Bob-Tach™ frame
- Cab door
- CE certification
- Deluxe operator cab*
Includes interior cab foam, side, top and rear windows, accessory wire harness, dome light, and electrical power port
- Electrically activated proportional front auxiliary hydraulics
- Engine/hydraulics system shutdown
- Hydraulic bucket positioning (including ON/OFF switch)
- Instrumentation
- Lift arm support
- Operating lights, front and rear
- Parking brake
- Seat bar
- Seat belt
- Tracks – rubber – 450 mm
- Turbo-charger with approved spark arrestor

* **Roll Over Protective Structure (ROPS) – meets requirements of SAE-J1040 and ISO 3471**

Options and Accessories

Below is a list of some equipment available from your Bobcat Loader dealer as Dealer and / or Factory Installed Accessories and Factory Installed Options. See your Bobcat dealer for other available options, accessories and attachments.

- Dealer Installed Accessories
 - 7-pin attachment control kit (standard with T250H)
 - Back up alarm kit
 - Cab enclosure kit
 - Door sensor kit
 - FOPS kit**
 - Four-point lift kit
 - Fresh air heater kit
 - Front door kit
 - Fuel cap locking kit
 - Operator cab, CE, enclosure kit
 - Plumbing kit for fresh air heater
 - Rear auxiliary hydraulic kit
 - Replacement Bob-Tach™
 - Single-point lift kit
- Special applications kitFactory Options
 - Advanced Control System (ACS)
 - Advanced Hand Controls (AHC)
 - Air conditioning
 - Cab enclosure with heat
 - Deluxe instrument panel
 - Power Bob-Tach™
 - Selectable Joystick Controls (SJC)

** **Falling Objects Protective Structure (FOPS) – meets requirements of SAE-J1043 and ISO 3449, Level I**

Specifications subject to change without notice.

FEATURES, ACCESSORIES AND ATTACHMENTS (CONT'D)

These and other attachments are approved for use on this model loader. Do not use unapproved attachments. Attachments not manufactured by Bobcat may not be approved.

The versatile Bobcat loader quickly turns into a multi-job machine with a tight-fit attachment hook-up . . . from bucket to grapple to pallet fork to backhoe and a variety of other attachments.

See your Bobcat dealer for more details on these and other attachments and field accessories.

Increase the versatility of your Bobcat loader with a variety of bucket styles and sizes.

Attachments

For specific model availability, see Bobcat Product Price List.

- Angle blade
- Angle broom*†
- Auger
- Backhoe
- Box blade
- Brushcat rotary cutter
- Buckets
- Chipper*
- Combination bucket
- Concrete pump*
- Cutter crusher*
- Digger
- Dozer blade*
- Dumping hopper
- Farm grapple
- Grader*
- Hydraulic breaker**
- Industrial grapple
- Landplane
- Landscape rake
- Mixing bucket*
- Pallet fork – hydraulic
- Pallet fork – standard
- Planer*
- Rear stabiliser
- Scarifier
- Snow blower*
- Sod layer*
- Soil conditioner*
- Spreader
- Stump grinder*
- Super scraper
- Sweeper
- Three-point hitch
- Tiller
- Tilt-Tatch™
- Tracks, steel
- Tree transplanter*
- Trench compactor
- Trencher
- Utility forks
- Utility frame
- Vibratory roller
- Water kit
- Wheel saw
- Whisker broom

* Attachment control kit required.

** When operating the loader with this attachment, a Special Applications Kit, which includes a 12 mm Lexan front door with 6 mm top and rear windows, must be used.

† Optional water kit.

Buckets Available

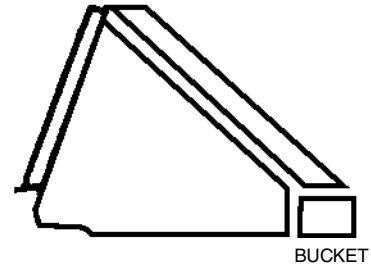

Many bucket styles, widths and different capacities are available for a variety of different applications. They include Construction & Industry, Low profile, Fertilizer and Snow, to name a few. See your Bobcat dealer for the correct bucket for your Bobcat loader and application.



Bobcat®

SAFETY

FIRE PREVENTION	XV
MACHINE SIGNS (DECALS)	XVI
SAFETY INSTRUCTIONS FOR BOBCAT SKID-STEER LOADERS AND ATTACHMENTS	XIII
Safe Operation Is The Operator's Responsibility	XIII
Safe Operation Needs A Qualified Operator	XIV

SAFETY



Bobcat®

SAFETY INSTRUCTIONS FOR BOBCAT SKID-STEER LOADERS AND ATTACHMENTS

Safe Operation Is The Operator's Responsibility

Carefully follow the operating and maintenance instructions in this manual.

The Bobcat skid-steer loader is highly maneuverable and compact. It is rugged and useful under a wide variety of conditions. This presents an operator with hazards associated with off highway, rough terrain applications, common with Bobcat loader usage.

The Bobcat has an internal combustion engine with resultant heat and exhaust. All exhaust gasses can kill or cause illness so use the loader with adequate ventilation. The loader has a spark arrestor exhaust system or muffler which is required for operation in certain areas.

The dealer explains the capabilities and restrictions of the Bobcat loader and attachments for each application. The dealer demonstrates the safe operation according to Bobcat instructional materials, which are also available to operators. The dealer can also identify unsafe modifications or use of unapproved attachments. The attachments and buckets are designed for a Rated Operating Capacity (some have restricted lift heights) and secure fastening to the Bobcat loader. The user must check with the dealer, or Bobcat literature, to determine safe loads of materials of specified densities for the loader-attachment combination.

The following publications and training materials provide information on the safe use and maintenance of the loader and attachments:

- The Delivery Report is used to assure that complete instructions have been given to the new owner and that the machine is in safe operating condition.
- The Operation & Maintenance Manual delivered with the Bobcat loader or attachment gives operating information as well as routine maintenance and service procedures. It is a part of the loader and can be stored in a container provided inside the cab of the loader. Replacement Operation & Maintenance Manuals can be ordered from your Bobcat dealer.
- Machine signs (decals) instruct on the safe operation and care of your Bobcat loader or attachment. The signs and their locations are shown in the Operation & Maintenance Manual. Replacement signs are available from your Bobcat dealer.

- An Operator's Handbook is fastened to the operator cab of the loader. Its brief instructions are convenient to the operator. The Handbook is available from your dealer in an English edition or one of many other languages. See your Bobcat dealer for more information on translated versions.

BEFORE OPERATING THE BOBCAT LOADER



Safety Alert Symbol

This symbol with a warning statement means: **“Warning, be alert! Your safety is involved!”** Carefully read the message that follows.



WARNING

Operator must have instructions before operating the machine. Untrained operators can cause injury or death.

W-2001-0502

IMPORTANT

This notice identifies procedures which must be followed to avoid damage to the machine.

I-2019-0284



WARNING

Warnings on the machine and in the manuals are for your safety. Failure to obey warnings can cause injury or death.

W-2044-1285

The Bobcat loader and attachment must be in good operating condition before use.

Check all of the items on the Bobcat Service Schedule Decal under the 8-10 hour column or as shown in the Operation & Maintenance Manual.

Safe Operation Needs A Qualified Operator

For an operator to be qualified, he must not use drugs or alcoholic drinks which impair his alertness or coordination while working. An operator who is taking prescription drugs must get medical advice to determine if he can safely operate a machine.

A Qualified Operator Must Do The Following:

Understand the Written Instructions, Rules and Regulations

- The written instructions from Bobcat company include the Delivery Report, Operation & Maintenance Manual, Operator's Handbook and machine signs (decals).
- Check the rules and regulations at your location. The rules may include an employer's work safety requirements. Regulations may apply to local driving requirements or use of a Slow Moving Vehicle (SMV) emblem. Regulations may identify a hazard such as a utility line.

Have Training with Actual Operation

- Operator training must consist of a demonstration and verbal instruction. This training is given by your Bobcat dealer before the product is delivered.
- The new operator must start in an area without bystanders and use all the controls until he can operate the machine and attachment safely under all conditions of the work area. Always fasten seat belt before operating.

Know the Work Conditions

- Know the weight of the materials being handled. Avoid exceeding the Rated Operating Capacity of the machine. Material which is very dense will be heavier than the same volume of less dense material. Reduce the size of load if handling dense material.
- The operator must know any prohibited uses or work areas, for example, he needs to know about excessive slopes.
- Know the location of any underground lines.
- Wear tight fitting clothing. Always wear safety glasses when doing maintenance or service. Safety glasses, hearing protection or special applications kit are required for some work. See your dealer about Bobcat Safety equipment.

SI02-0903

FIRE PREVENTION

The machines and some attachments have components that are at high temperatures under normal operating conditions. The primary source of high temperatures is the engine and exhaust system. The electrical system, if damaged or incorrectly maintained, can be a source of arcs or sparks.

Flammable debris (leaves, straw, etc.) must be removed regularly. If flammable debris is allowed to accumulate, it can cause a fire hazard. Clean often to avoid this accumulation. Flammable debris in the engine compartment is a potential fire hazard.

The spark arrestor exhaust system (if equipped) is designed to control the emission of hot particles from the engine and exhaust system, but the muffler and the exhaust gases are still hot.

- Do not use the machine where exhaust, arcs, sparks or hot components can contact flammable material, explosive dust or gases.
- The operator cab, engine compartment and engine cooling system must be inspected every day and cleaned if necessary to prevent fire hazards and overheating.
- Check all electrical wiring and connections for damage. Keep the battery terminals clean and tight. Repair or replace any damaged part.
- Check fuel and hydraulic tubes, hoses and fittings for damage and leakage. Never use open flame or bare skin to check for leaks. Tighten or replace any parts that show leakage. Always clean fluid spills. Do not use gasoline or diesel fuel for cleaning parts. Use commercial nonflammable solvents.
- Do not use ether or starting fluids on any engine which has glow plugs. These starting aids can cause explosion and injure you or bystanders.

- Always clean the machine, disconnect the battery, and disconnect the wiring from the Bobcat controllers before welding. Cover rubber hoses, battery and all other flammable parts. Keep a fire extinguisher near the loader when welding. Have good ventilation when grinding or welding painted parts. Wear dust mask when grinding painted parts. Toxic dust or gas can be produced.
- Stop the engine and let it cool before adding fuel. No smoking!
- Use the procedure in the Operation & Maintenance Manual for connecting the battery.
- Use the procedure in the Operation & Maintenance Manual for cleaning the spark arrestor muffler (if equipped).

Figure 4



- Know where fire extinguishers and first aid kits are located and how to use them. Fire extinguishers are available from your Bobcat dealer. The fire extinguisher can be installed in the location shown in **[Figure 4]**.

SI03-0301

MACHINE SIGNS (DECALS)

Follow the instructions on all the Machine Signs (Decals) that are on the loader. Replace any damaged machine signs and be sure they are in the correct locations. Machine signs are available from your Bobcat loader dealer.

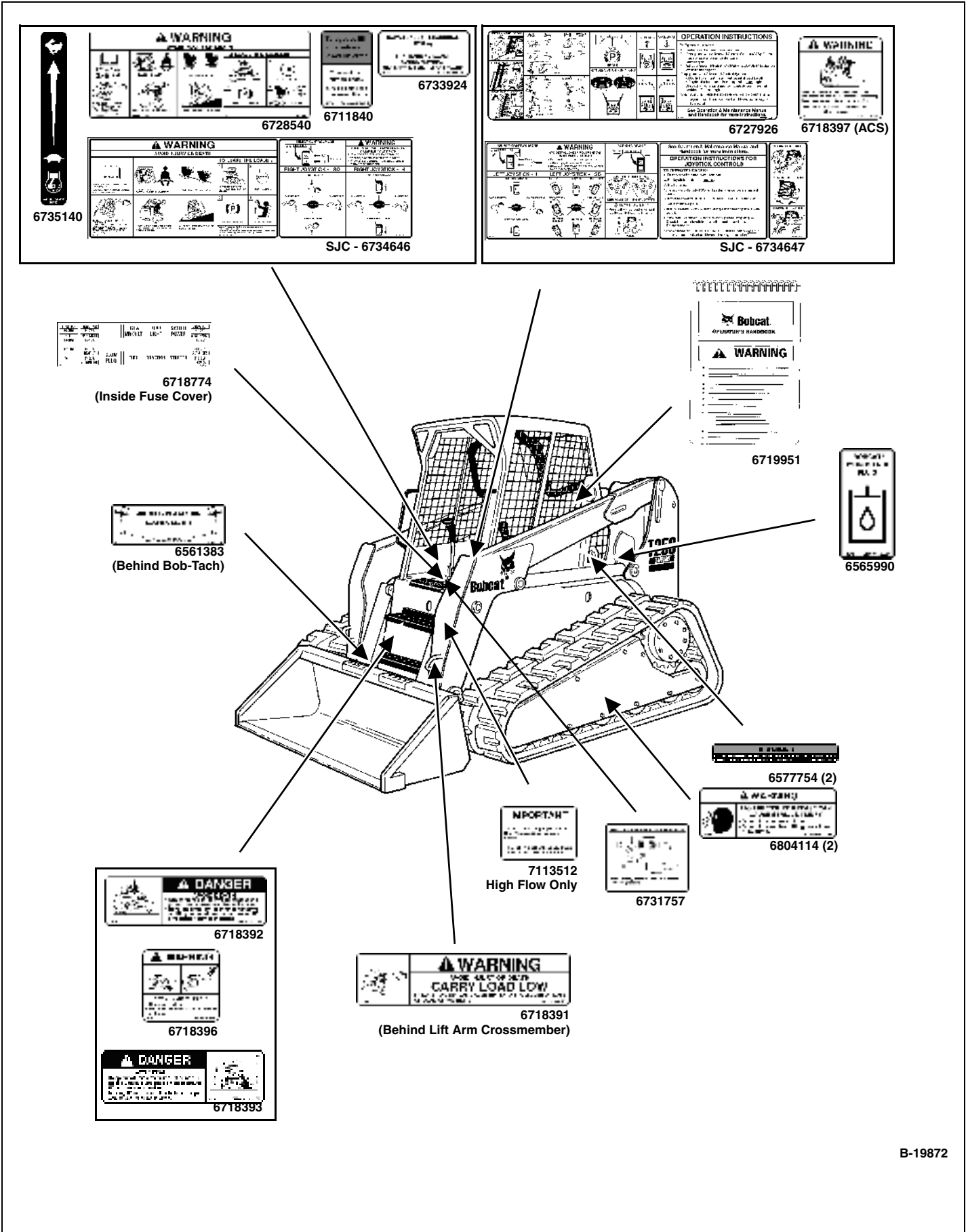

B-19872



Bobcat®

OPERATING INSTRUCTIONS

ATTACHMENTS AND BUCKETS	OI-33
Hand Lever Bob-Tach - Installing The Bucket Or Attachment	OI-34
Hand Lever Bob-Tach - Removing The Bucket Or Attachment	OI-36
Pallet Forks	OI-34
Power Bob-Tach - Installing The Bucket Or Attachment	OI-37
Power Bob-Tach - Removing The Bucket Or Attachment	OI-38
Selecting The Correct Bucket	OI-33
DAILY INSPECTION	OI-24
Daily Inspection and Maintenance Checklist.....	OI-24
DRIVING AND STEERING THE LOADER.....	OI-12
Available Controls Configurations	OI-12
Operation (SJC in 'H' Control Pattern)	OI-13
Operation (SJC in 'ISO' Control Pattern)	OI-14
Operation (Standard and ACS)	OI-12
Using The Steering Levers To Stop The Loader	OI-15
ENGINE SPEED CONTROL	OI-11
Operation	OI-11
HYDRAULIC CONTROLS	OI-16
Advanced Control System (ACS) in HAND Control Mode	OI-17
Attachment Control Device (ACD) (If Equipped)	OI-22
Auxiliary Hydraulics Button - DISENGAGE	OI-20
Auxiliary Hydraulics Button - MAXIMUM FLOW ONLY	OI-20
Auxiliary Hydraulics Button - VARIABLE FLOW.....	OI-20
hydrAulic controls (cont'd)	OI-23
FRONT Auxiliary Hydraulics Operation - CONTINUOUS FLOW ...	OI-20
FRONT Auxiliary Hydraulics Operation - MAXIMUM FLOW	OI-20
FRONT Auxiliary Hydraulics Operation - VARIABLE FLOW	OI-20
High-Flow Hydraulics Operation (If Equipped)	OI-22
Quick Couplers.....	OI-19
REAR Auxiliary Hydraulics Operation	OI-21
Releasing Hydraulic Pressure (Loader and Attachment)	OI-19
Secondary Front Auxiliary Hydraulics (If Equipped).....	OI-21
Selectable Joystick Control (SJC) - 'H' Control Pattern	OI-18
Selectable Joystick Control (SJC) - 'ISO' Control Pattern.....	OI-18
Standard Controls (Also ACS in Foot Pedal Mode)	OI-16
INSTRUMENT PANEL IDENTIFICATION.....	OI-5
Cab Light.....	OI-10
Left Panel	OI-5
Right Panel (Deluxe - With Keyless Start).....	OI-7
Right Panel (Standard - With Key Switch).....	OI-6
Option And Field Accessory Panels (If Equipped)	OI-9
INCHING CONTROL.....	OI-11
Operation	OI-11

OPERATING INSTRUCTIONS

OPERATING INSTRUCTIONS (CONT'D)

LIFT ARM BY-PASS CONTROL	OI-10
Operation.....	OI-10
MONITORING THE DISPLAY PANEL	OI-32
Deluxe Panel	OI-32
Standard Panel.....	OI-32
WARNING and SHUTDOWN	OI-32
OPERATING PROCEDURE.....	OI-39
Compact Track Loader Operating Tips.....	OI-41
Foot Pedal Machines	OI-42
Hand Control Machines (Includes ACS and SJC with H-Pattern Selected)	OI-44
Operating With A Full Bucket.....	OI-39
Operating With An Empty Bucket	OI-40
Selectable Joystick Control (SJC) with 'ISO' Pattern Selected.....	OI-46
PARKING BRAKE	OI-23
Operation.....	OI-23
PARKING THE BOBCAT LOADER	OI-48
Parking Procedure	OI-48
PRE-STARTING PROCEDURES	OI-25
Before Starting The Engine	OI-25
SEAT BAR RESTRAINT SYSTEM	OI-15
Operation.....	OI-15
STARTING THE ENGINE (DELUXE PANEL, KEYLESS START)	OI-29
Cold Temperature Starting.....	OI-30
Starting Procedure	OI-29
STARTING THE ENGINE (STANDARD PANEL, KEY SWITCH).....	OI-27
Starting Procedure	OI-27
STOPPING THE BOBCAT LOADER	OI-15
Using The Steering Levers To Stop The Loader.....	OI-15
STOPPING THE ENGINE	OI-31
Stopping Procedure.....	OI-31
TOWING THE LOADER.....	OI-50
Towing Procedure.....	OI-50
TRACTION LOCK OVERRIDE	OI-10
Operation.....	OI-10

OPERATING INSTRUCTIONS (CONT'D)

TRANSPORTING THE BOBCAT LOADER.....	OI-49
Fastening To Transport Vehicle	OI-49
Loading Onto Transport Vehicle	OI-49
WARMING THE HYDRAULIC / HYDROSTATIC SYSTEM	OI-31
Warming Procedure	OI-31



Bobcat®

INSTRUMENT PANEL IDENTIFICATION

Left Panel

Figure OI-1

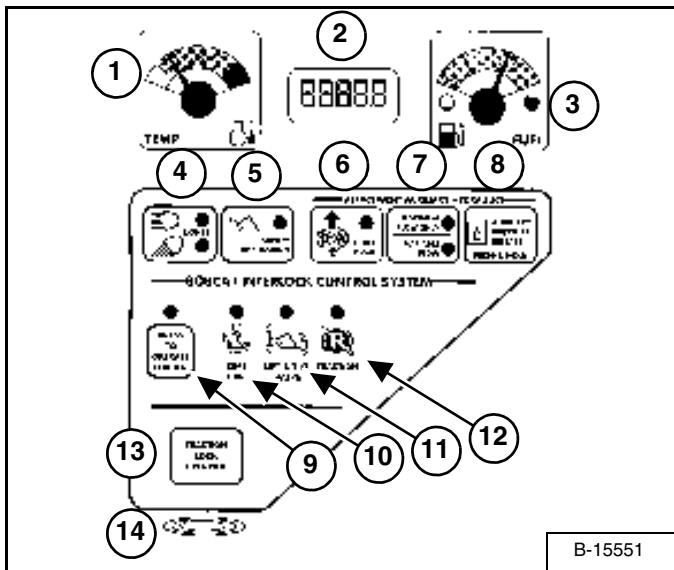

The left instrument panel is the same for both the Standard and Deluxe Instrument Panels [Figure OI-1].

The table below shows the DESCRIPTION and FUNCTION/OPERATION for each of the components of the left panel.

REF. NO	DESCRIPTION	FUNCTION / OPERATION
1	TEMPERATURE GAUGE	Shows the engine coolant temperature.
2	HOURMETER / CODE DISPLAY / GLOW PLUG COUNTDOWN	HOURMETER - Records operating hours of loader. CODE DISPLAY - Display numeric SERVICE CODES* relating to the loader monitoring system. COUNTDOWN - Preheat time remaining.
3	FUEL GAUGE	Shows the amount of fuel in the tank.
4	LIGHTS / HOLD FOR CODES	LIGHTS - Press once for FRONT LIGHTS. Press a second time for FRONT AND REAR lights. Press a third time to turn all lights off. HOLD FOR CODES - Press and hold two seconds for display of SERVICE CODES (Item 2). (CODES* show only when there is an error found by loader monitoring system.)
5	BUCKET POSITIONING (Option)	Press to engage the BUCKET POSITIONING function. Press again to disengage. Press and hold 2 seconds to view SHTDN (SHUTDOWN) feature & Operational Code Number in HOURMETER / CODE DISPLAY.
ATTACHMENT AUXILIARY HYDRAULICS		
6	HIGH FLOW (Option)	Press to engage the HIGH FLOW auxiliary hydraulics. Press again to disengage.
7	MAXIMUM FLOW / VARIABLE FLOW	Press once to engage the VARIABLE FLOW auxiliary hydraulics. Press a second time to engage MAXIMUM FLOW. Press a third time to disengage all auxiliary hydraulics. [VARIABLE FLOW allows for slow-to-fast movement of auxiliary functions (The farther you move the switch, the faster the movement of auxiliary functions.) MAXIMUM FLOW allows for only fast movement.]
8	AUXILIARY PRESSURE RELEASE	Rear Auxiliray Only - With key ON or engine running, press and hold button for 5 seconds. (See Releasing Hydraulic Pressure - Loader and Attachment Page OI-19 for front auxiliary pressure release.)
BOBCAT INTERLOCK CONTROL SYSTEM (BICS™) (See SYSTEM ANALYSIS, Page SA-3 for more information.)		
9	PRESS TO OPERATE LOADER	Press to activate BICS™ System when the Seat Bar is down and operator is seated in operating position.
10	SEAT BAR	The light comes ON when the seat bar is down.
11	LIFT & TILT VALVE	The light comes ON when the seat bar is down and the PRESS TO OPERATE Button is pressed. The lift and tilt functions <u>can</u> be operated when the light is ON.
12	TRACTION	The light comes ON when the seat bar is down, engine is running, and parking brake is released. The loader <u>can</u> be moved forward or backward when the light is ON.
13	TRACTION LOCK OVERRIDE	(Function Only When Seat Bar Is Raised And The Engine Is Running) Press to unlock the brakes. Allows you to use the steering levers to move the loader forward or backward when using the backhoe attachment or for loader service. (See TRACTION LOCK OVERRIDE Page OI-10). Press a second time to lock the brakes.
14	ALARM	The ALARM beeps when there is an Error, WARNING or SHUTDOWN condition.

* See SYSTEM SETUP & ANALYSIS, Page SA-4 for further description of SERVICE CODES.

INSTRUMENT PANEL IDENTIFICATION (CONT'D)

Right Panel (Standard - With Key Switch)

Figure OI-2

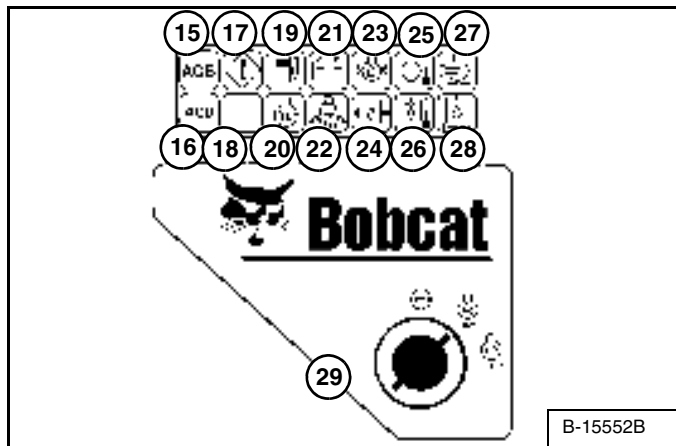

The right instrument panel shown [Figure OI-2] is the Standard Panel.

The table below shows the Icons and other components of the Right Standard Panel

* These functions are monitored and have SERVICE CODES associated with them. For descriptions, (See DIAGNOSTICS SERVICE CODES on Page SA-4).

REF.	FUNCTION	ICON/LIGHT	ALARM	CODE	CONDITION	DESCRIPTION
15	Advanced Control System (ACS) (Opt.)	ON	3 Beeps	*	Error	Error with Advanced Control System (ACS) or Selectable Joystick Control (SJC)
16	Attachment Control Device (ACD) (Opt.)	ON FLASHING	--- 3 Beeps	--- ---	--- Error	Electrical controlled attachment is present. Error with Attachment Control Device (ACD)
17	General Warning	ON ON FLASHING	3 Beeps 3 Beeps Continuous	* * *	Error WARNING SHUTDOWN	Error with one or more engine or hydraulic functions. Engine speed high or in shutdown. Engine speed very high. Engine will stop in 10 seconds.
18	NOT USED					
19	Fuel Level	ON FLASHING	3 Beeps 3 Beeps	* *	Error WARNING	Fuel level sender system fault. Fuel level low.
20	Glow Plugs	ON FLASHING	--- 3 Beeps	--- ---	--- Error	Air Intake Heater is energized. Error with Air Intake Heater
21	System Voltage	ON	3 Beeps	*	WARNING	Voltage low, high or very high.
22	Seat Belt	ON	---	---	---	Light stays on for 45 seconds to remind operator to fasten seat belt.
23	Engine Oil Pressure	ON ON FLASHING	3 Beeps 3 Beeps Continuous	* * *	Error WARNING SHUTDOWN	Engine Oil Pressure sender out of range. Engine oil level low. Engine oil pressure very low. Engine will shutdown in 10 seconds.
24	Hydrostatic Charge Pressure	ON ON FLASHING	3 Beeps 3 Beeps Continuous	* * *	Error WARNING SHUTDOWN	Hydraulic oil pressure sender out of range. Hydraulic oil pressure low. Hydraulic charge pressure very low. Engine will stop in 10 seconds.
25	Engine Coolant Temperature	ON ON FLASHING	3 Beeps 3 Beeps Continuous	* * *	Error WARNING SHUTDOWN	Engine coolant sender out of range. Engine coolant temperature high. Engine coolant temperature very high. Engine will stop in 10 seconds.
26	Hydraulic Oil Temperature	ON ON FLASHING	3 Beeps 3 Beeps Continuous	* * *	Error WARNING SHUTDOWN	Hydraulic oil temperature out of range. Hydraulic oil temperature high. Hydraulic oil temperature very high. Engine will stop in 10 seconds.
27	Engine Air Filter	ON FLASHING	3 Beeps 3 Beeps	* *	Error WARNING	Air filter with high restriction. Air filter switch not connected.
28	Hydraulic Filter	ON FLASHING	3 Beeps 3 Beeps	* *	Error WARNING	Hydraulic filter with high restriction. Hydraulic filter switch not connected.
29	Key Switch	---	---	---	---	Used to start and stop the engine.

INSTRUMENT PANEL IDENTIFICATION (CONT'D)

Right Panel (Deluxe - With Keyless Start)

Figure OI-3

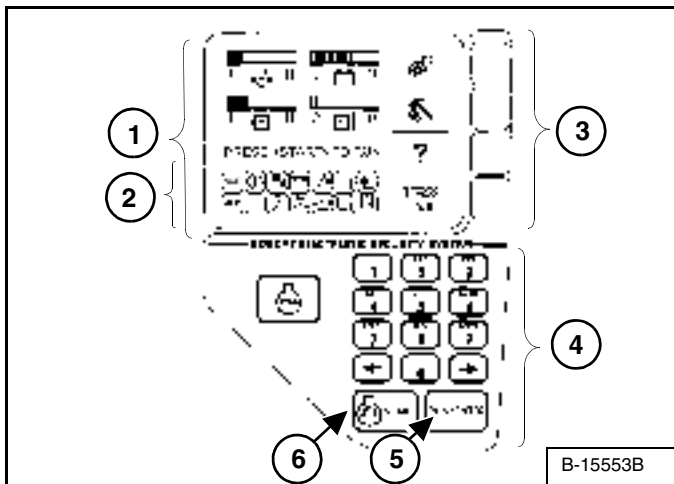

The right instrument panel shown [Figure OI-3] is the Deluxe Panel.

1. **Display Panel:** The Display Panel is where all system setup, monitoring, troubleshooting, and error conditions are displayed.
2. **Function Icons:** The lower left area of the Deluxe Panel has the same Icons as the Standard Panel. These Icons are only visible when the monitoring system has detected an error.
3. **Selection Buttons:** The four Selection Buttons allow you to select items from the Display Panel and scroll through screens.
4. **Keypad:** The numeric keypad (Item 4) [Figure OI-3] has two functions:

To enter a number code (password) to allow starting the engine (Keyless Start).

To enter a number as directed for further use of the Display Panel.

Figure OI-4

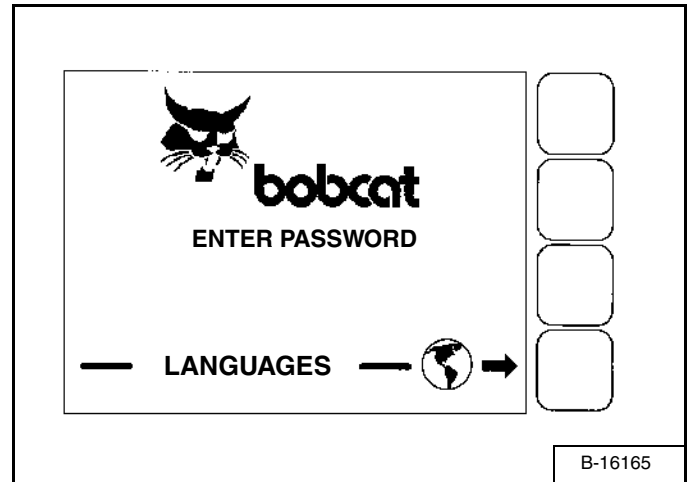

The first screen you will see on your new loader will be as shown in [Figure OI-4].

When this screen is on the display you can enter the password and start the engine or change the Display Panel setup features.

NOTE: Your new loader (with Deluxe Instrument Panel) will have an Owner Password. Your dealer will provide you with this password. Change the password to one that you will easily remember to prevent unauthorized use of your loader. (See Passwords (Deluxe) on Page SA-10.) Keep your password in a safe place for future needs.

Start Engine: Use the Keypad to enter the numbers (letters) of your password and press the RUN / ENTER key (Item 5) [Figure OI-3].

Press and hold the START Button (Item 6) [Figure OI-3] until the engine starts.

Change Language: Press the Selection Button at the end of the arrow [Figure OI-4] to go to the next screen.

INSTRUMENT PANEL IDENTIFICATION (CONT'D)

Right Panel (Deluxe - With Keyless Start) (Cont'd)

Figure OI-5

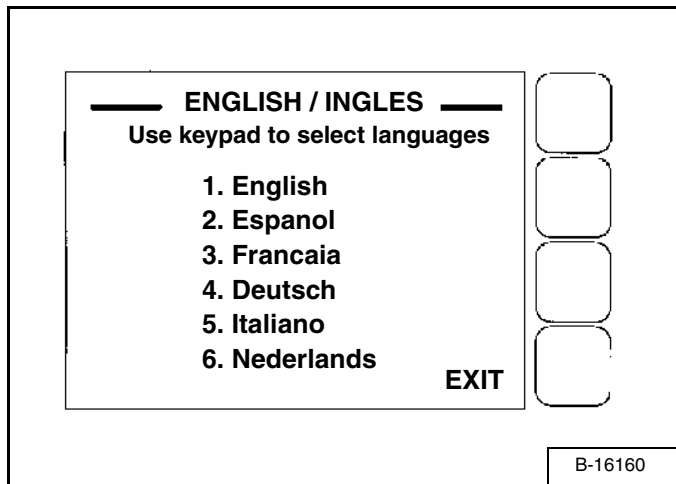

Use the Keypad to select the number of the language [Figure OI-3].

Press EXIT. The screen will return to [Figure OI-5]. You can then enter the password and start the engine.

(See DELUXE INSTRUMENT PANEL SETUP on Page SA-9) for further description of screens to setup the system for your use.

NOTE: Pressing the EXIT key will go to the pervious screen and you can continue pressing until you get to the initial (home) screen.
SHORTCUT: Press the "0" (zero) key to get to the home screen immediately.

INSTRUMENT PANEL IDENTIFICATION (CONT'D)

Option And Field Accessory Panels (If Equipped)

Figure OI-6

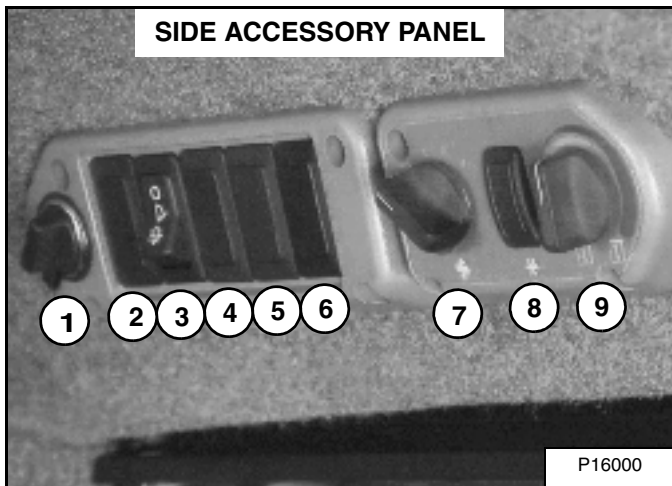

Side Accessory Panel [Figure OI-6]

REF. NO.	DESC.	FUNCTION/OPERATION
1.	POWER PLUG	Provides a 12V receptacle for accessories.
2.	NOT USED	---
3.	FRONT WIPER	Press the top of the switch to start the front wiper (press and hold for washer fluid). Press the bottom of the switch to stop the wiper.
4.	REAR WIPER	Press the bottom of the switch to start the rear wiper. Press the top of the switch to provide washer fluid to clean the rear window.
5.	NOT USED	---
6.	NOT USED	---
7.	FAN MOTOR	Turn clockwise to increase fan speed; counterclockwise to decrease. There are four positions; OFF-1-2-3.
8.	AIR COND. SWITCH	Press top of switch to start; bottom to stop. Fan Motor (Item 7) must be ON for A/C to operate.
9.	TEMP. CONTROL	Turn clockwise to increase the temperature; counterclockwise to decrease.

Figure OI-7

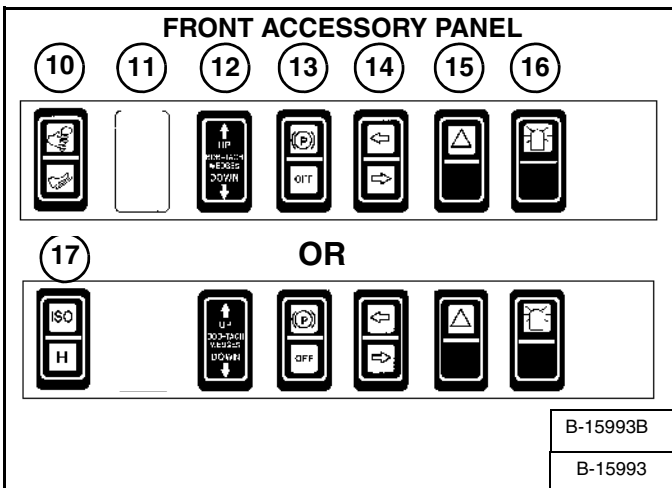

NOTE: Parking Brake (Item 13) [Figure OI-7] is Standard on all loaders.

Front Accessory Panel [Figure OI-7]

REF. NO.	DESC.	FUNCTION/OPERATION
10.	ADVANCED CONTROL SYSTEM (ACS)	Press the top to select Hand Controls; bottom to select Foot Controls.
11.	NOT USED	---
12.	POWER BOB-TACH	Press and hold the up arrow to disengage the the Bob-Tach wedges. Press and hold the down arrow to engage the wedges into the mounting frame holes.
13.	PARKING BRAKE (Standard on all Loaders)	Press the top to engage the PARKING BRAKE; bottom to disengage.
14.	TURN SIGNAL INDICATORS	Indicates left or right TURN SIGNALS are ON.
15.	HAZARD LIGHTS	Press the top to turn the HAZARD LIGHTS ON; bottom to turn OFF.
16.	ROTATING BEACON	Press the top to turn the ROTATING BEACON ON; bottom to turn OFF.
17.	SELECTABLE JOYSTICK CONTROL (SJC)	Press the top to select 'ISO' Control Pattern; bottom to select 'H' Control Pattern.

INSTRUMENT PANEL IDENTIFICATION (CONT'D)

Cab Light

Figure OI-8

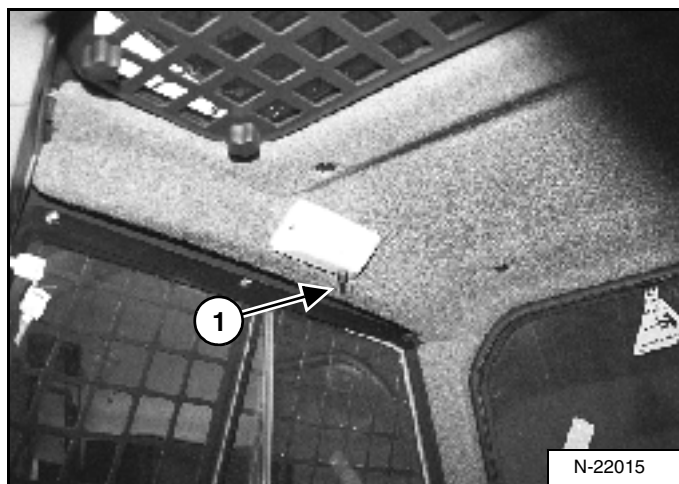

Push the button (Item 1) [Figure OI-8] to turn the light ON. Push the button again to turn OFF.

LIFT ARM BY-PASS CONTROL

Operation

Figure OI-9

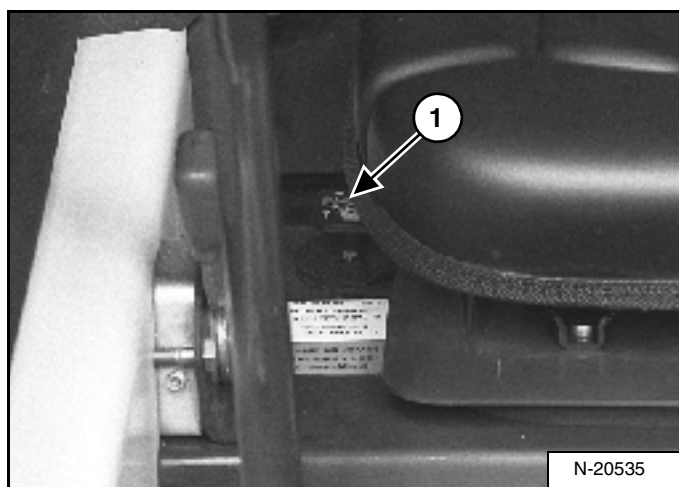

The lift arm by-pass control (Item 1) [Figure OI-9] is used to lower the lift arms if the lift arms cannot be lowered during normal operations.

- Sit in the operator's seat.
- Fasten the seat belt and lower the seat bar.
- Turn the knob (Item 1) [Figure OI-9] clockwise 1/4 turn.
- Pull up and hold the knob until the lift arms slowly lower.

TRACTION LOCK OVERRIDE

Operation

Figure OI-10

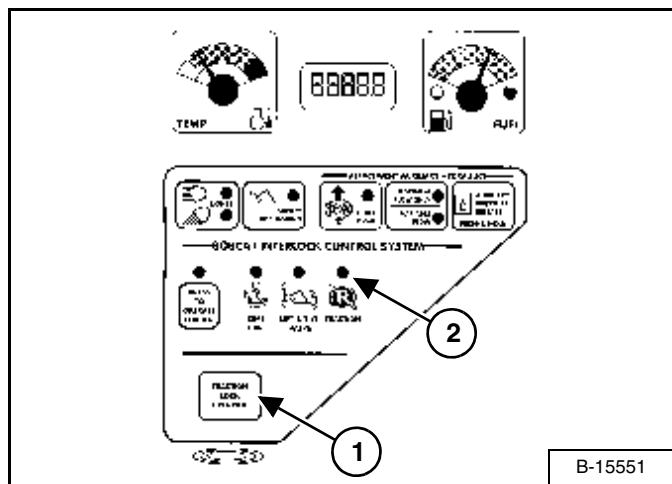

(Functions Only When The Seat Bar Is Raised And The Engine Is Running) There is a TRACTION LOCK OVERRIDE Button (Item 1) [Figure OI-10] on the left instrument panel which will allow you to use the steering levers to move the loader forward and backward when using the backhoe attachment or for loader service.

- Press the TRACTION LOCK OVERRIDE button once to unlock traction lock drive. The TRACTION light (Item 2) [Figure OI-10] will be ON.
- Press the button a second time to lock the traction drive. The TRACTION light (Item 2) [Figure OI-10] will be OFF.

ENGINE SPEED CONTROL

Operation

Figure OI-11

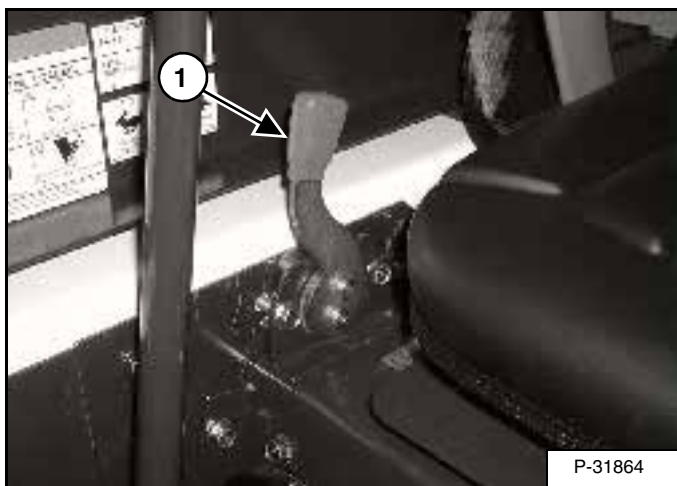

The speed control lever is at the right side of the operator's seat (Item 1) [Figure OI-11].

Move the lever forward to increase engine speed. Move backward to decrease engine speed.

INCHING CONTROL

Operation

The Inching Control allows the loader to be maneuvered at slow travel speed for installing attachments, loading or unloading.

Figure OI-12

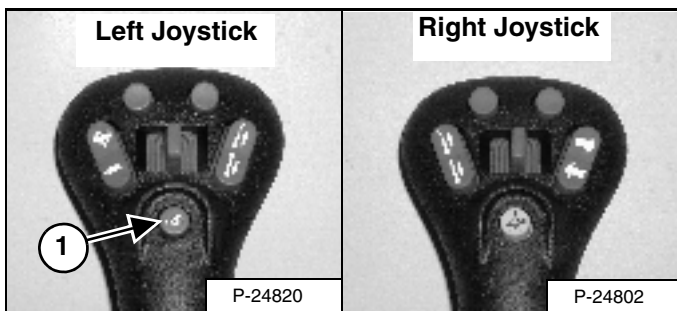

Press the button (Item 1) [Figure OI-12] on the left joystick once to engage the Inching Control.

Figure OI-13

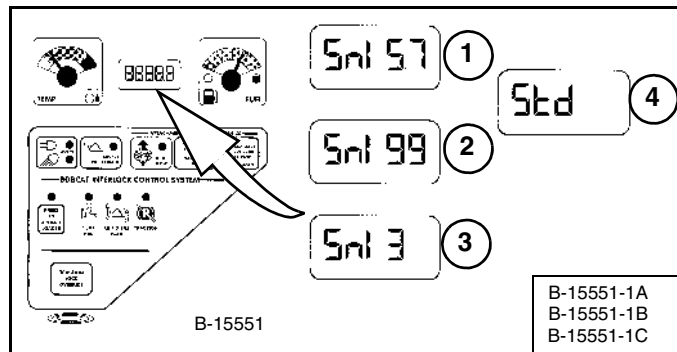

When the Inching Control is engaged, the machine will travel at 57% of Standard travel speed and the percentage (**Snl 57**) will appear in the display (Item 1) [Figure OI-13].

While Inching Control is engaged, press the top of the Two-Speed switch (Item 1) [Figure OI-12] to increase the speed up to 99% (**Snl 99**) or the bottom of the switch to decrease the speed down to 3% (**Snl 3**). The percentages will appear in the display (Items 2 and 3) [Figure OI-13].

Press button (Item 1) [Figure OI-12] again to disengage Inching Control and return to Standard Travel Speed (**Std** (Item 4) [Figure OI-13] will appear in display.) You must return to Standard Travel Speed before engaging the Two-Speed Control for High Range Speed.

The system will retain the speed percentage as long as the key remains ON (Standard Panel) or the STOP button has not been pressed (Deluxe Panel).

EXAMPLE: You can be using the machine at 40% and then disengage the Inching Control to reposition the loader, then re-engage Inching Control. The speed percentage will still be at 40%.

If you turn the key OFF or press the STOP button, the next time you start the engine and engage the Inching Control, the speed will be at 57% of Standard Travel Speed.

DRIVING AND STEERING THE LOADER

Available Controls Configurations

The loader has three configurations available:

- **Standard Controls** - Two Steering Levers control drive and steering functions.
- **Advanced Control System (ACS) (Option or Field Accessory)** - Two Steering Levers control drive and steering functions.
- **Selectable Joystick Controls (SJC) (Option)** - (*'ISO' Pattern*) Left joystick controls the drive and steering functions.

(*'H' Pattern*) Left and right joysticks control left and right side drive and steering functions.

Operation (Standard and ACS)

Figure OI-14

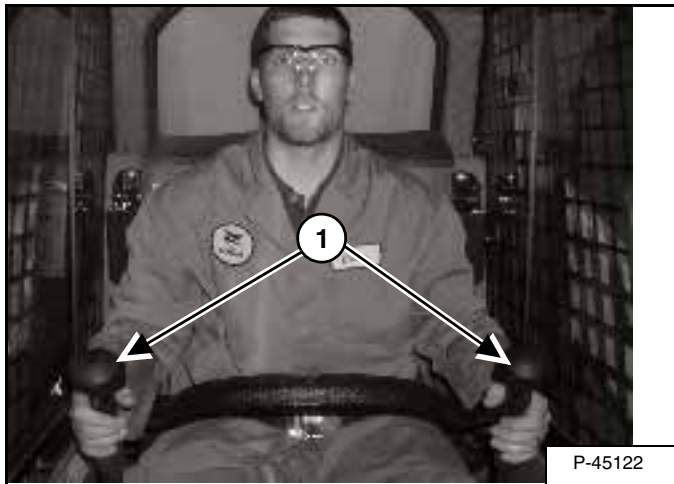

The steering levers (Item 1) [Figure OI-14] are on the left and right side in front of the seat.

Move the levers smoothly. Avoid sudden starting and stopping.

Figure OI-15

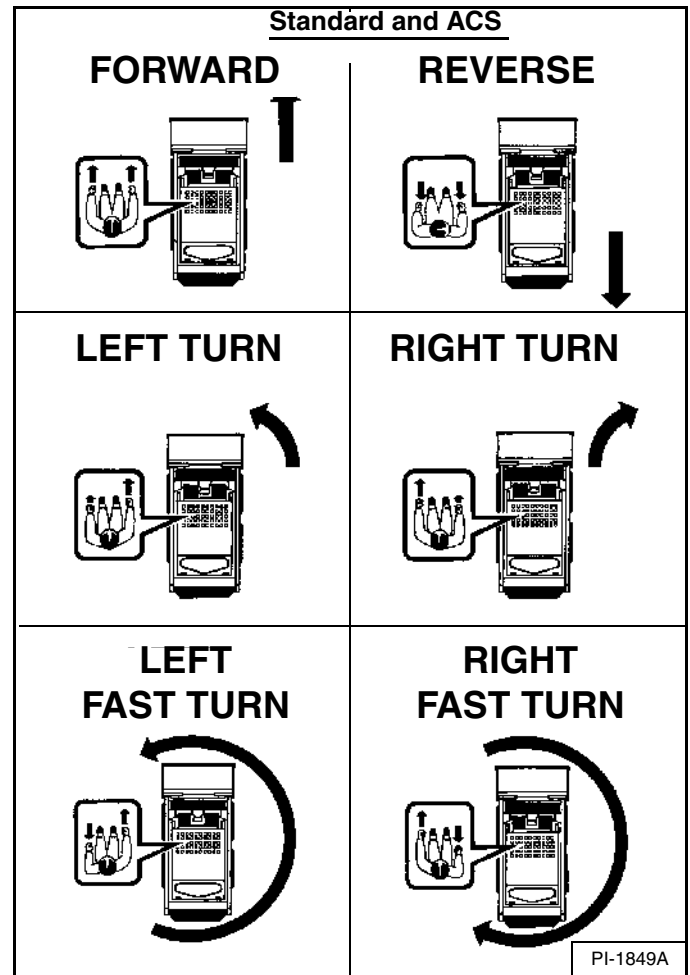

The steering levers control forward and reverse travel and turning the loader [Figure OI-15].

Forward Travel - Push both levers forward.

Reverse Travel - Pull both levers backward.

Normal Turning - Move one lever farther forward than the other.

Fast Turning - Push one lever forward and pull the other lever backward.

WARNING

AVOID INJURY OR DEATH

When operating the machine:

- Keep the seat belt fastened snugly.
- The seat bar must be lowered.

Keep your feet on the pedal controls or footrests and hands on steering levers.

W-2261-0799

DRIVING AND STEERING THE LOADER (CONT'D)

Operation (SJC in 'H' Control Pattern)

Figure OI-16

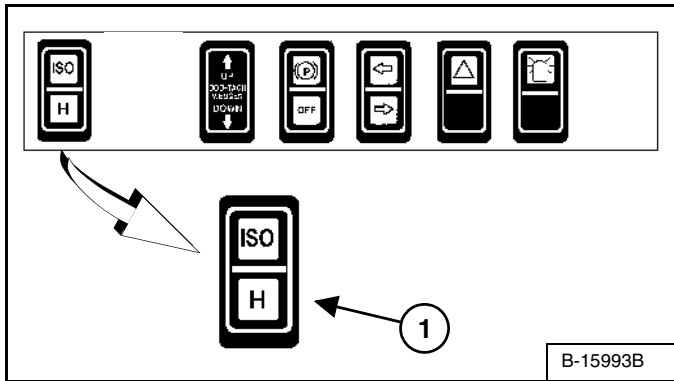

Select the 'H' control pattern by pressing the bottom of the switch (Item 1) [Figure OI-16].



AVOID INJURY OR DEATH

When operating the machine:

- Keep the seat belt fastened snugly.
- The seat bar must be lowered.
- Keep your feet on the foot rests and hands on control levers.

W-2399-0501

Figure OI-17

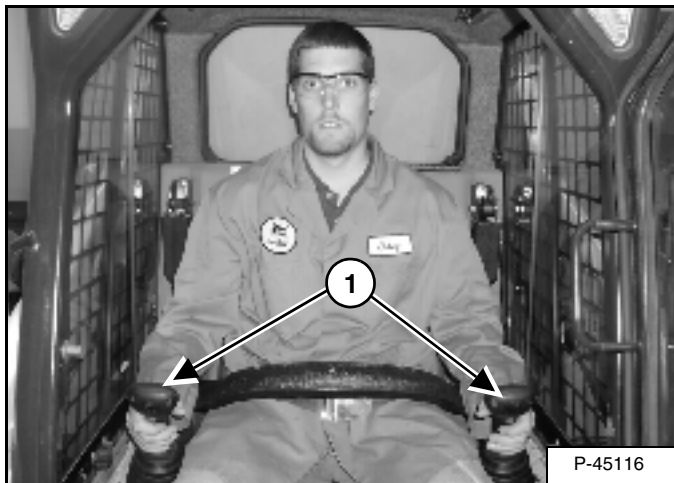

Both joysticks control drive and steering and are located on the right and left side in front of the seat (Item 1) [Figure OI-17].

Figure OI-18

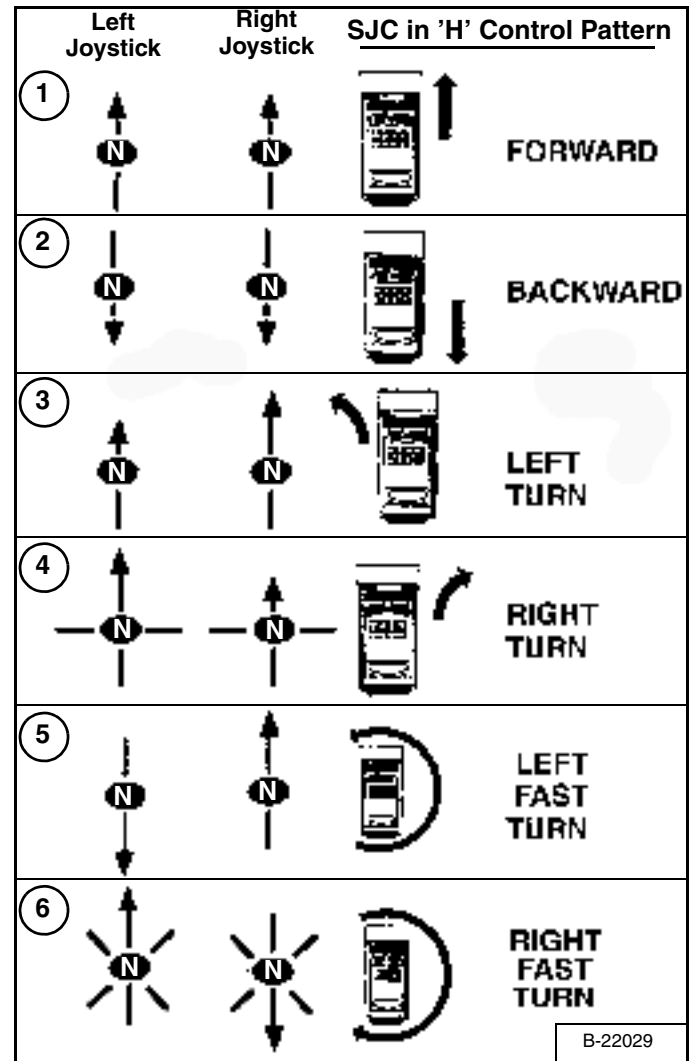

Hand Control Functions (Drive and Steering) [Figure OI-18]

1. **Forward Travel** - Move both joysticks forward.
2. **Backward Travel** - Move both joysticks backward.
3. **Forward Left Turn** - Move the right joystick farther forward than the left joystick.
4. **Forward Right Turn** - Move the left joystick farther forward than the right joystick.
5. **Left Fast Turn** - Move the left joystick backward and the right joystick forward.
6. **Right Fast Turn** - Move the left joystick forward and the right joystick backward.

DRIVING AND STEERING THE LOADER (CONT'D)

Operation (SJC in 'ISO' Control Pattern)

Figure OI-19

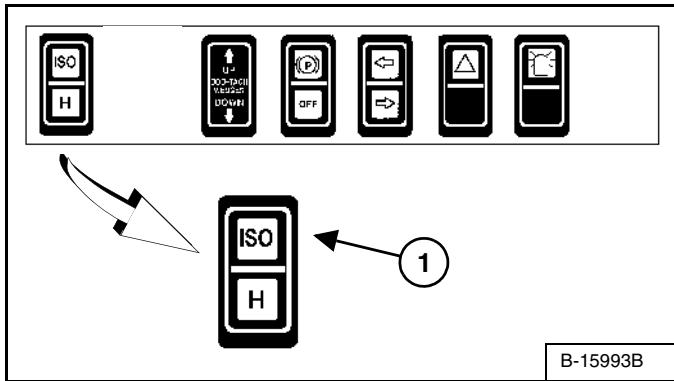

Select the 'ISO' control pattern by pressing the top of the switch (Item 1) [Figure OI-19].



AVOID INJURY OR DEATH

When operating the machine:

- Keep the seat belt fastened snugly.
- The seat bar must be lowered.
- Keep your feet on the foot rests and hands on control levers.

W-2399-0501

Figure OI-20

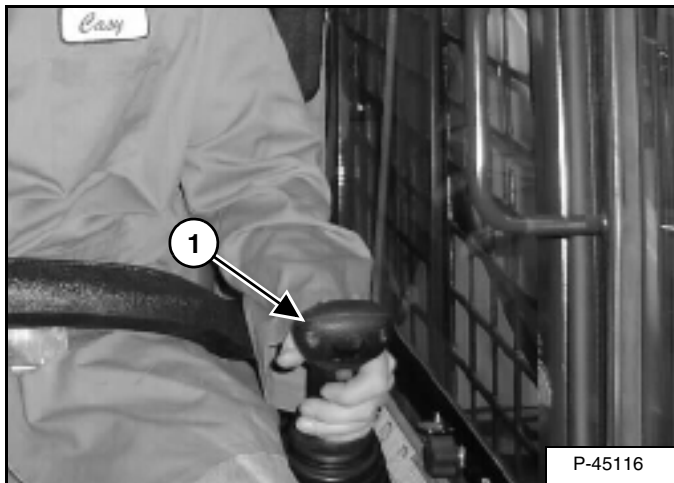

The joystick which controls drive and steering is on the left side in front of the seat (Item 1) [Figure OI-20].

Figure OI-21

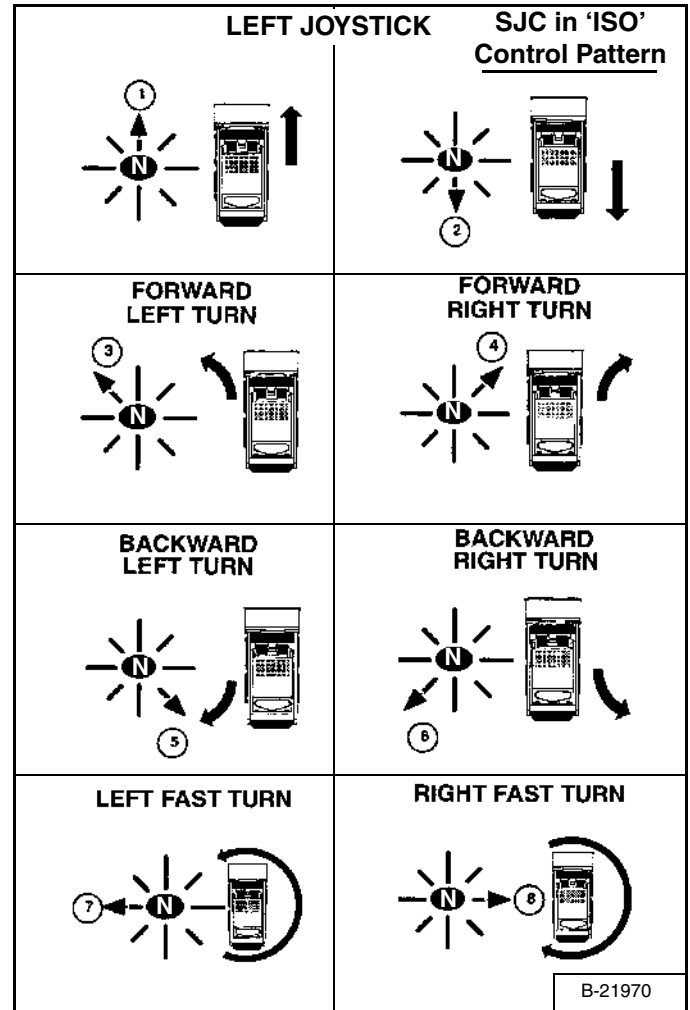

Left Joystick Functions (Drive and Steering) [Figure OI-21]

Move the joystick smoothly. Avoid sudden starting and stopping.

1. **Forward Travel** - Move joystick forward.
2. **Backward Travel** - Move joystick backward.
3. **Forward Left Turn** - Move joystick forward and to the left.
4. **Forward Right Turn** - Move joystick forward and to the right.
5. **Backward Left Turn** - Move joystick backward and to the right.
6. **Backward Right Turn** - Move joystick backward and to the left.
7. **Left Fast Turn** - Move joystick to the left.
8. **Right Fast Turn** - Move joystick to the right.

STOPPING THE BOBCAT LOADER

Using The Steering Levers To Stop The Loader

When the steering levers are moved to the neutral position, the hydrostatic transmission will act as a service brake to stop the loader.

SEAT BAR RESTRAINT SYSTEM

Operation

Figure OI-22



The seat bar restraint system has a pivoting seat bar with arm rests (Item 1) [Figure OI-22].

The operator controls the use of the seat bar. The seat bar in the down position helps to keep the operator in the seat.

WARNING

AVOID INJURY OR DEATH

When operating the machine:

- **Keep the seat belt fastened snugly.**
- **The seat bar must be lowered.**
- **Keep your feet on the pedal controls or footrests and hands on steering levers.**

W-2261-0799

When the seat bar is down, the PRESS TO OPERATE LOADER button is activated, and the brake is released, the lift, tilt, and traction drive functions can be operated. (Traction drive will operate only when the engine is running.)

When the seat bar is up, the lift, tilt and traction drive functions are deactivated and both foot pedals (if equipped) will be locked.

WARNING

Before you leave the operator's seat:

- **Lower the lift arms, put the attachment flat on the ground.**
- **Stop the engine.**
- **Engage the parking brake.**
- **Raise seat bar**
- **(Foot Pedal Controls) Move pedals until both lock.**
- **(Advanced Control System - ACS) Move the hydraulic controls to the NEUTRAL POSITION to make sure that both lift and tilt functions are deactivated.**

The seat bar system must deactivate the lift and tilt control functions when the seat bar is up. Service the system if controls do not deactivate.

- **(Selectable Joystick Control - SJC) Move the joysticks to the NEUTRAL POSITION to make sure that travel and hydraulic functions are deactivated.**

The seat bar system must deactivate these functions when the seat bar is up. Service the system if controls do not deactivate.

W-2463-0603

HYDRAULIC CONTROLS

Standard Controls (Also ACS in Foot Pedal Mode)

Two foot pedals (or optional hand controls) control the hydraulic cylinders for the lift and tilt functions.

Put your feet on the pedals (or footrests) and **KEEP THEM THERE** any time you operate the loader.

Figure OI-23

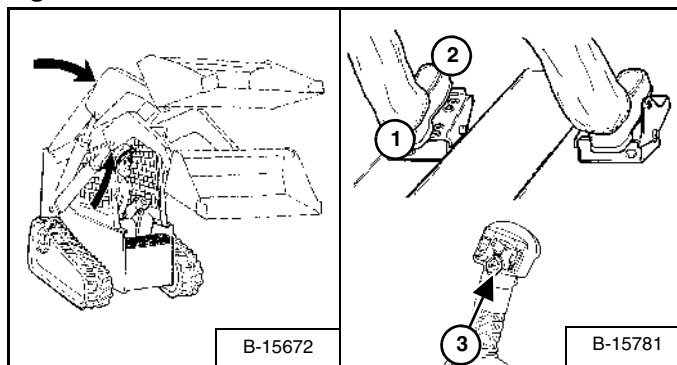

Lift Arm Operation - (Left Pedal)

Push the heel (Item 1) [Figure OI-23] of the pedal to raise the lift arms.

Push the toe (Item 2) [Figure OI-23] of the pedal to lower the lift arms.

Lift Arm Float Position - (Left Pedal)

Push the toe (Item 2) [Figure OI-23] of the pedal all the way forward until it locks into the float position.

Use the float position of the lift arms to level loose material while driving backward.

Raise the lift arms to disengage the float position.

Lift Arm Float Position (With ACS) - (Left Pedal)

Press and hold the Float button (Item 3) [Figure OI-23].

Push the toe (Item 2) [Figure OI-23] of the pedal forward to lower the lift arms. Then release the float button.

Use the float position of the lift arms to level loose material while driving backward.

Raise the lift arms to disengage the float position.

Figure OI-24

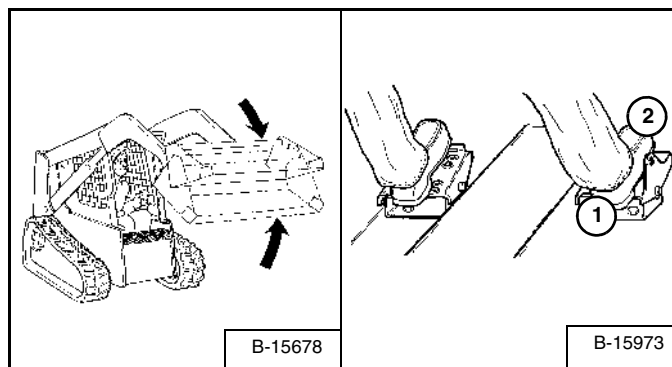

Tilt Operation - (Right Pedal)

Push the heel (Item 1) [Figure OI-24] of the pedal to tilt the bucket backward.

Push the toe (Item 2) [Figure OI-24] of the pedal to tilt the bucket forward.

HYDRAULIC CONTROLS (CONT'D)

Advanced Control System (ACS) in HAND Control Mode

Figure OI-25

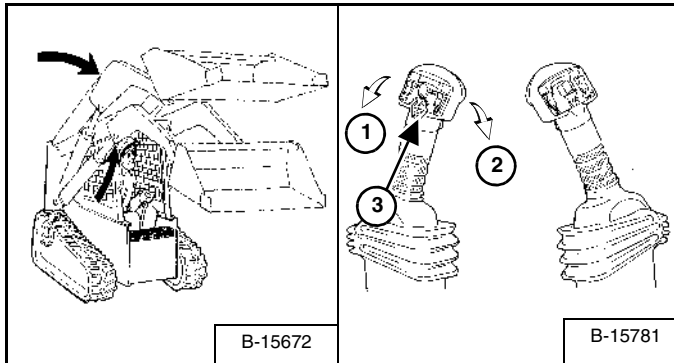

Lift Arm Operation - (Left Hand Lever)

Move the lever outward (Item 1) [Figure OI-25] to raise the lift arms.

Move the lever inward (Item 2) [Figure OI-25] to lower the lift arms.

Lift Arm Float Position - (Left Hand Lever)

Press and hold the Float Button (Item 3) [Figure OI-25] while the lever is in neutral. Move the lever to lift arm down position (Item 2) [Figure OI-25], then release the button.

Press Float Button again or move the lever to lift arm up position (Item 3) [Figure OI-25] to disengage.

Use the float position of the lift arms to level loose material while driving backward.

Figure OI-26

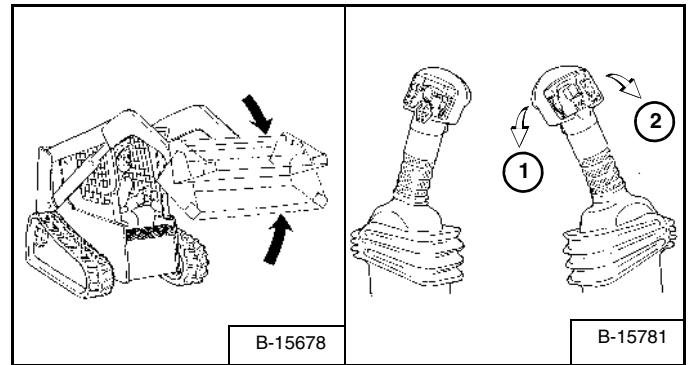

Tilt Operation - (Right Hand Lever)

Move the lever inward (Item 1) [Figure OI-26] to tilt the bucket backward.

Move the lever outward (Item 2) [Figure OI-26] to tilt the bucket forward.

HYDRAULIC CONTROLS (CONT'D)

Selectable Joystick Control (SJC) - 'H' Control Pattern

Figure OI-27

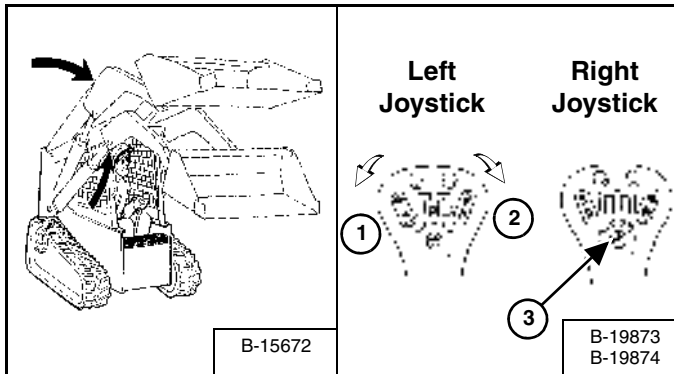

Lift Arm Operation - (Left Hand Joystick)

Move the joystick outward (Item 1) [Figure OI-27] to raise the lift arms.

Move the joystick inward (Item 2) [Figure OI-27] to lower the lift arms.

Lift Arm Float Position - (Left & Right Hand Joysticks)

Press and hold the Float Button (Item 3) [Figure OI-27] while the joysticks are in neutral. Move the left joystick to lift arm down position (Item 2) [Figure OI-27], then release the button.

Press Float Button again or move the left joystick to lift arm up position (Item 3) [Figure OI-27] to disengage.

Use the float position of the lift arms to level loose material while driving backward.

Figure OI-28

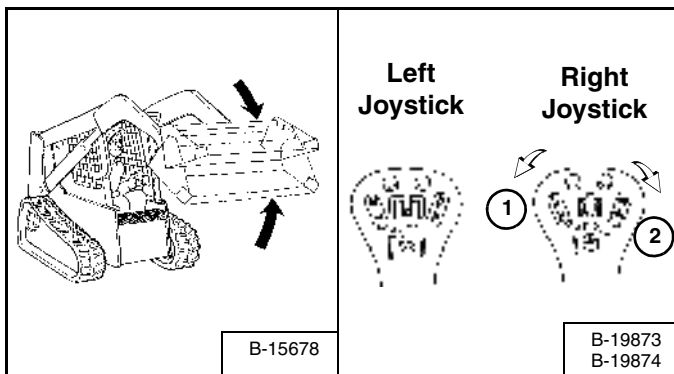

Tilt Operation - (Right Hand Joystick)

Move the joystick inward (Item 1) [Figure OI-28] to tilt the bucket backward.

Move the joystick outward (Item 2) [Figure OI-28] to tilt the bucket forward.

Selectable Joystick Control (SJC) - 'ISO' Control Pattern

Figure OI-29

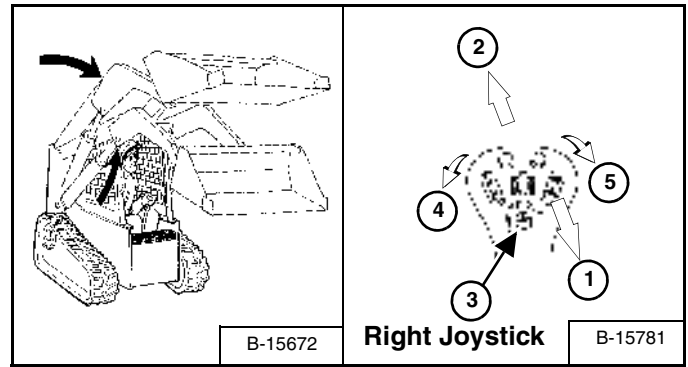

Lift Arm Operation - (Right Hand Joystick)

Move the joystick backward (Item 1) [Figure OI-29] to raise the lift arms.

Move the joystick forward (Item 2) [Figure OI-29] to lower the lift arms.

Lift Arm Float Position - (Right Hand Joystick)

Press and hold the Float Button (Item 3) [Figure OI-29] while the joystick is in neutral. Move the joystick to lift arm down position (Item 2) [Figure OI-29], then release the button.

Press Float Button again or move the joystick to lift arm up position (Item 2) [Figure OI-29] to disengage.

Use the float position of the lift arms to level loose material while driving backward.

Tilt Operation - (Right Hand Joystick)

Move the joystick inward (Item 4) [Figure OI-29] to tilt the bucket backward.

Move the joystick outward (Item 5) [Figure OI-29] to tilt the bucket forward.

HYDRAULIC CONTROLS (CONT'D)

Quick Couplers

Figure OI-30

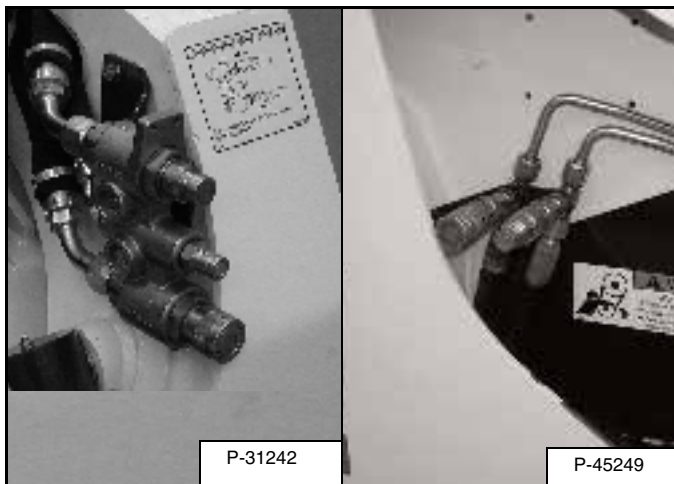

To Connect: Remove dirt or debris from the surface of both the male and female couplers, and from the outside diameter of the male coupler. Visually check the couplers for corroding, cracking, damage or excessive wear. If any of these conditions exist, the coupler(s) [Figure OI-30] must be replaced.

Install the male coupler into the female coupler. Full connection is made when the ball release sleeve slides forward on the female coupler.

To Disconnect: Hold the male coupler. Retract the sleeve on the female coupler until the couplers disconnect.

Releasing Hydraulic Pressure (Loader and Attachment)

Front Auxiliary Quick Couplers

When Connecting: Push the quick couplers tightly together and hold for five seconds; the pressure is automatically released as the couplers are connected.

When Disconnecting: Push the quick couplers tightly together and hold for five seconds; then retract the sleeve until the couplers disconnect.

Rear Auxiliary Quick Couplers

Figure OI-31

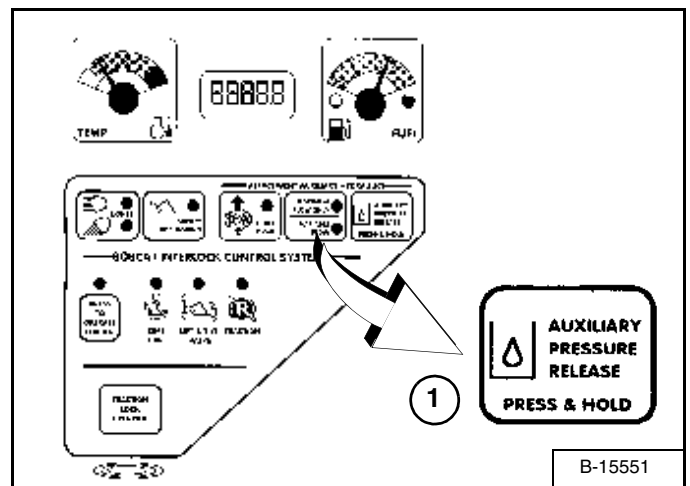

Press the AUXILIARY PRESSURE RELEASE Button (Item 1) [Figure OI-31]. Hold it for two seconds after the engine comes to a complete stop. The pressure will be released.

WARNING

AVOID BURNS

Hydraulic fluid, tubes, fittings and quick couplers can get hot when running machine and attachments. Be careful when connecting and disconnecting quick couplers.

W-2220-0396

HYDRAULIC CONTROLS (CONT'D)

Auxiliary Hydraulics Button - VARIABLE FLOW

Figure OI-32

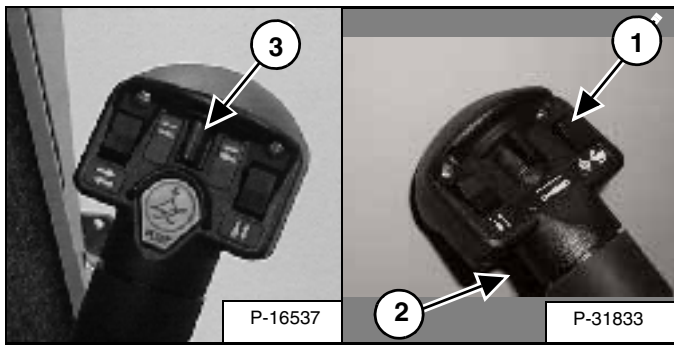

NOTE: The appearance of Joysticks is different than handles shown [Figure OI-32] but hydraulic function is the same.

VARIABLE FLOW allows for slow-to-fast movement of auxiliary functions. If you move the auxiliary switch (Item 1) [Figure OI-32] half way, the auxiliary functions move at approximately one-half speed.

Figure OI-33

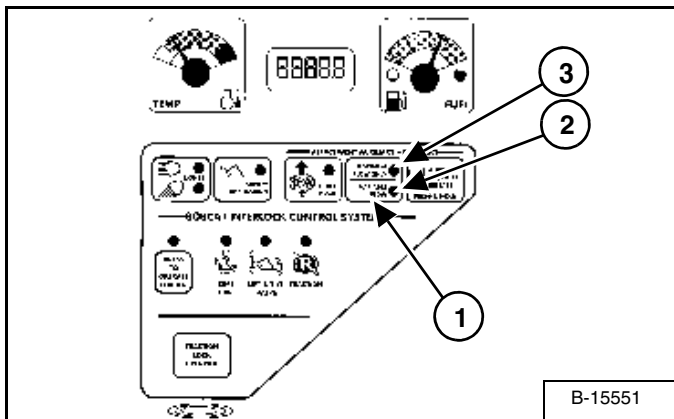

Press the auxiliary hydraulics button (Item 1) [Figure OI-33] once.

The light (Item 2) [Figure OI-33] will be ON.

Auxiliary Hydraulics Button - MAXIMUM FLOW ONLY

MAXIMUM FLOW ONLY allows for fast movement only. If you move the auxiliary switch (Items 1 or 3) [Figure OI-32], the auxiliary functions move at fast speed; release the switch to stop auxiliary functions.

Press the auxiliary hydraulics button (Item 1) [Figure OI-33] a second time.

The light (Item 3) [Figure OI-33] will be ON.

Auxiliary Hydraulics Button - DISENGAGE

To disengage, press the auxiliary hydraulics button (Item 1) [Figure OI-33] a third time.

Both lights (Items 2 & 3) [Figure OI-33] will be OFF.

NOTE: When the operator is seated and raises the seat bar, the Auxiliary Hydraulic System (Front and Rear) will deactivate.

FRONT Auxiliary Hydraulics Operation - VARIABLE FLOW

Press the auxiliary hydraulics button for VARIABLE FLOW.

Push the switch (Item 1) [Figure OI-32] to the right or left to change the fluid flow direction of the front quick couplers. (EXAMPLE: Open and close grapple teeth.)

FRONT Auxiliary Hydraulics Operation - MAXIMUM FLOW

Press the auxiliary hydraulics button for MAXIMUM FLOW ONLY.

Push the switch (Item 1) [Figure OI-32] to the right or left to change the fluid flow direction of the front quick couplers. (EXAMPLE: Open and close grapple teeth.)

FRONT Auxiliary Hydraulics Operation - CONTINUOUS FLOW

After selecting VARIABLE or MAXIMUM FLOW, press the front switch (Item 2) [Figure OI-32] to give the front quick couplers a constant flow of fluid with the female coupler being pressurized. (EXAMPLE: Operate a backhoe.)

REVERSE CONTINUOUS FLOW - To set reverse flow (male coupler pressurized), select VARIABLE or MAXIMUM FLOW, then, while holding the auxiliary switch (Item 1) [Figure OI-32] to the left, press the front switch (Item 2) [Figure OI-32]. Reverse flow can be used only with augers, power rakes, sweepers, tillers, and vibratory rollers.

To release from continuous operation, press the front switch (Item 2) [Figure OI-32] a second time.

HYDRAULIC CONTROLS (CONT'D)

REAR Auxiliary Hydraulics Operation

Figure OI-34



The switches on the left hand lever control the rear auxiliary hydraulics.

Press the auxiliary hydraulics button for **MAXIMUM FLOW** (See Auxiliary Hydraulics Button - **MAXIMUM FLOW ONLY**).

Push the switch (Item 3) [Figure OI-32] to the right or left to change the fluid flow direction to rear quick couplers [Figure OI-34]. (EXAMPLE: Raise and lower rear stabilizers.)

WARNING

Diesel fuel or hydraulic fluid under pressure can penetrate skin or eyes, causing serious injury or death. Fluid leaks under pressure may not be visible. Use a piece of cardboard or wood to find leaks. Do not use your bare hand. Wear safety goggles. If fluid enters skin or eyes, get immediate medical attention from a physician familiar with this injury.

W-2007-0497

Secondary Front Auxiliary Hydraulics (If Equipped)

Figure OI-35

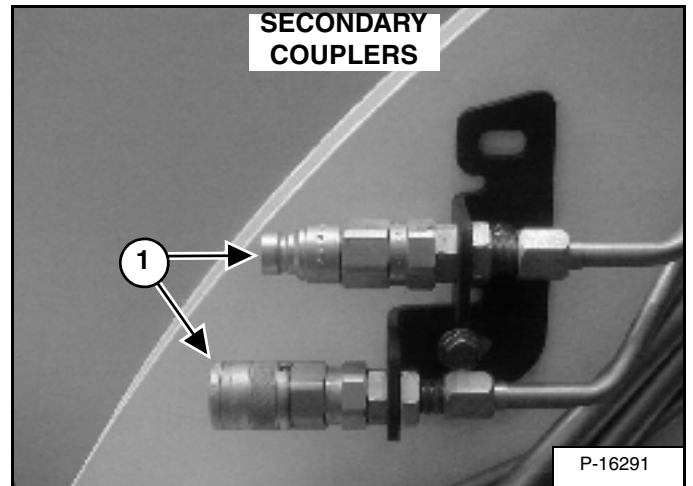

The secondary front auxiliary quick couplers (Item 1) [Figure OI-35] are available as a Field Installed Accessory. These are used when there is a need for additional auxiliary hydraulics (EXAMPLE: Planer side shift).

Connect the attachment to the secondary auxiliary hydraulics (Item 1) [Figure OI-35].

Set the Auxiliary Hydraulic Button for *Variable Flow* or *Maximum Flow Only*. (See Auxiliary Hydraulics Button - **VARIABLE FLOW** on Page OI-20) or (See Auxiliary Hydraulics Button - **MAXIMUM FLOW ONLY** on Page OI-20).

Figure OI-36

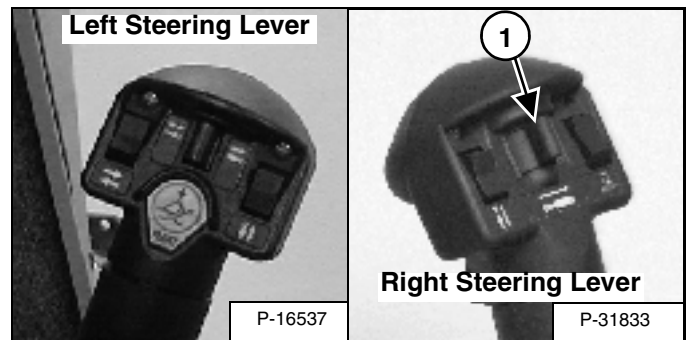

Push switch (Item 1) [Figure OI-36] to the right or left to change fluid flow direction. (EXAMPLE: Side shift on the Planer.)

NOTE: The secondary front auxiliary hydraulics *and* the rear auxiliary hydraulics operate from the same auxiliary section of the control valve. To operate only one of these auxiliary functions, disconnect the other.

HYDRAULIC CONTROLS (CONT'D)

High-Flow Hydraulics Operation (If Equipped)

Figure OI-37

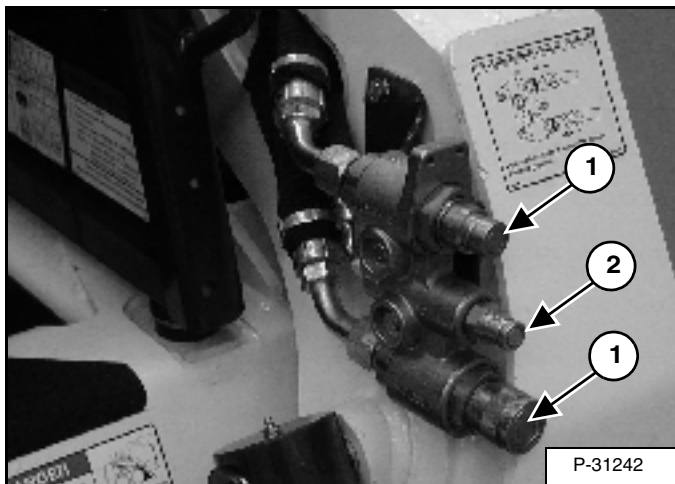

The High-Flow function provides additional flow to the system to operate an attachment which requires more hydraulic flow (EXAMPLE: Planer).

Connect the attachment to the quick couplers (Item 1) [Figure OI-37].

Some attachments may have a case drain which needs to be connected to the small quick coupler (Item 2) [Figure OI-37].

Figure OI-38

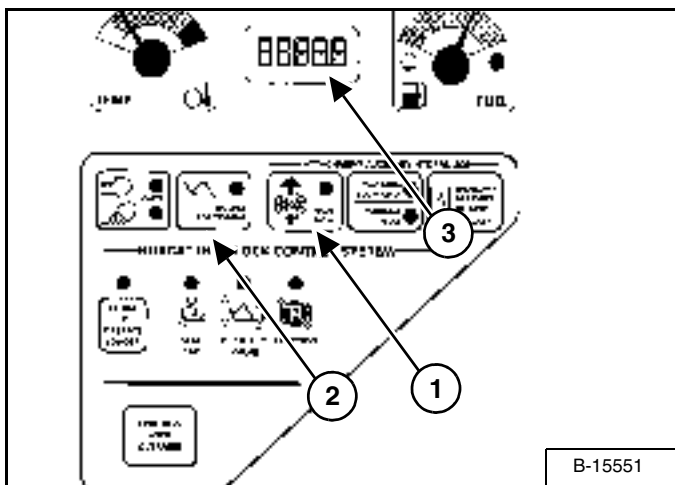

Press the HIGH FLOW button (Item 1) [Figure OI-38]. Press again to disengage.

Attachment Control Device (ACD) (If Equipped)

Figure OI-39

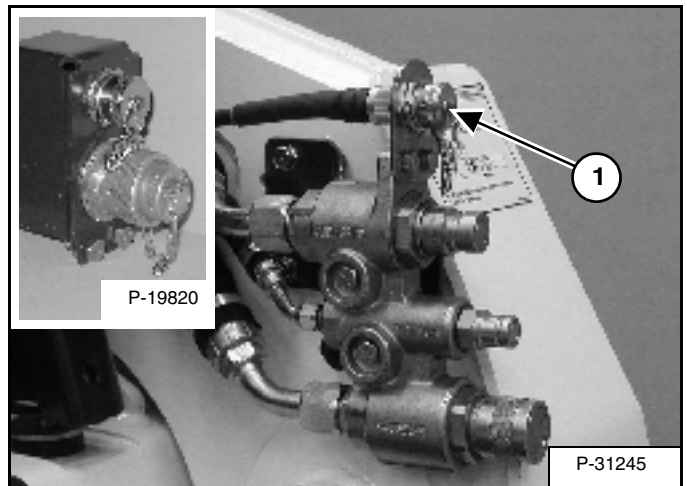

You will need the Dual-Connector (7-pin/14-pin) kit (Inset) [Figure OI-39] to operate early model attachments. The 7 pin connector is shown (Item 1) [Figure OI-39]. See your Bobcat loader dealer.

Figure OI-40

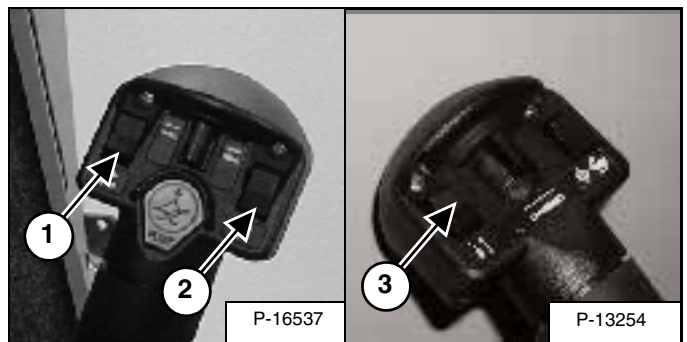

You can use additional switches (Items 1, 2, and 3) [Figure OI-40] on the right and left control handles for functions which control some attachments.

See the appropriate Attachment Operation & Maintenance Manual for control details.

HYDRAULIC CONTROLS (CONT'D)

Bucket Position Valve Operation (If Equipped)

The function of the bucket position valve is to keep the bucket in the same approximate position it is in before you begin raising the lift arms.

Press BUCKET POSITIONING button (Item 2) [Figure OI-38] to engage the bucket position function. (The light will be on.) Press again to disengage.

Bucket Positioning functions only during upward lift cycle.

Figure OI-41

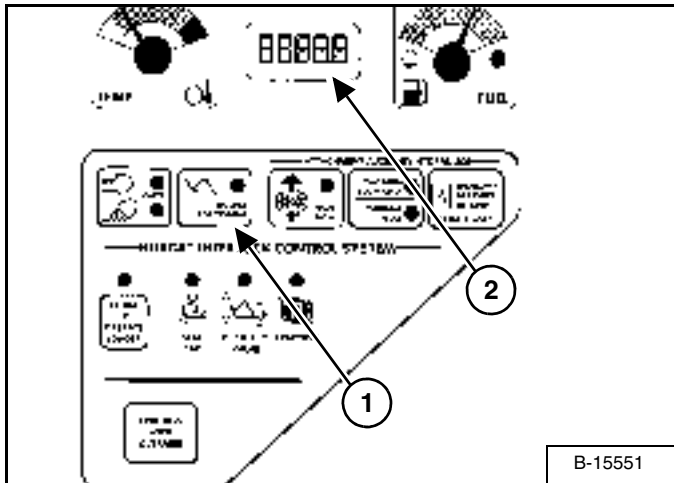

SHUTDOWN FEATURE

Press and hold the BUCKET POSITIONING button (Item 1) [Figure OI-41] for 2 seconds. Shtdn will appear in the HOURMETER / CODE DISPLAY (Item 2) [Figure OI-41]. (Operational Code will also appear.)

PARKING BRAKE

Operation

Figure OI-42

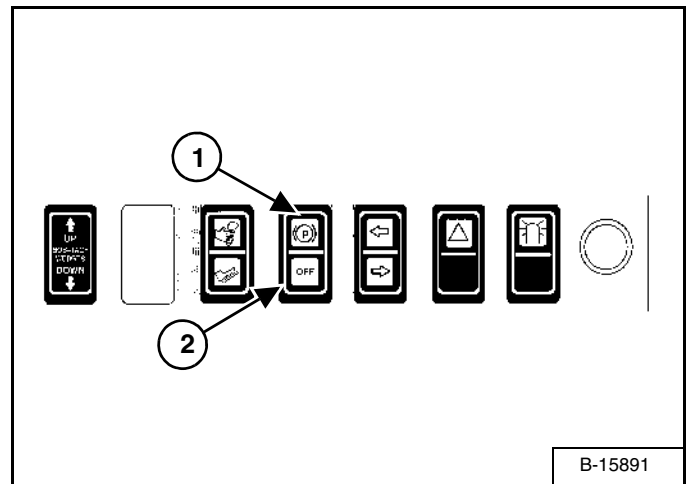

Press the top of the switch (Item 1) [Figure OI-42] to engage the parking brake. The traction drive system will be locked.

Press the bottom of the switch (Item 2) [Figure OI-42] to disengage the parking brake. The traction drive system will be unlocked.

NOTE: The TRACTION light on the left instrument panel will remain OFF until the engine is started, the PRESS TO OPERATE LOADER button is pressed and the parking brake is disengaged.

DAILY INSPECTION

<p>⚠ WARNING</p> <p>AVOID INJURY OR DEATH</p> <ul style="list-style-type: none"> Keep door closed except for service. Keep engine clean of flammable materials. Keep body, loose objects and clothing away from electrical contacts, moving parts, hot parts and exhausts. Do not use loader in areas with explosive dust or gases or with flammable materials near exhaust. Never use ether or starting fluid or alcohol to start with glow plug. Use only starting aids as approved by engine manufacturer. Leaking fluids under pressure can enter skin and cause serious injury. Battery acid can cause severe burns, wear goggles. If acid contacts eyes, skin or clothing, flush well with water. For contact to eyes, flush and get medical attention. Battery makes flammable and explosive gas. Keep area, sparks, flames and ignited tobacco away. For jump start, connect negative cable to loader engine last (never to the battery). After jump start, remove negative connection at the engine first. 	<p>SERVICE CHECKLIST AND SCHEDULE</p> <p>BEFORE THE DAILY STARTUP OF THE LOADER</p> <ul style="list-style-type: none"> ENGINE OIL & FILTER - Check level or add as needed. Do not overfill. Change oil and filter intervals: 50 Hr (Tractor) or Operator's Manual when a 20 Hr or greater of engine hours has been used. ENGINE AIR FILTER - Check condition before and on display. Service any other wear. Do not use earplugs to check air filter. FUEL FILTER - Check for leaks and no fuel pump operation. FUEL INJECTION SYSTEM - Check for leaks and fuel filter. Check coolant level and add if low. Add if required. FUEL FILTER - Remove trapped water. GLIDER LIFT ARMS, LIFT, DRIVE CYLINDERS, BOB-TACH PIVOT & WEDGES, STEERING CYLINDERS (AWD Machines Only) - Lubricate with multi-purpose heavy duty grease. ROTOR FINE TUNE FOR AIR CONTROL SYSTEM (AWD) - Fine tune air. Position engine around 1500 RPM. Adjust air flow as necessary. WHEEL - Check for correct fit and tire. Clean if dirt builds from moving parts. If tire is flat, replace with "RIP" approved tire and inflation. TIRE - Check for pressure. Inflate to MAXIMUM pressure shown on sidewall. GENERAL - Check for loose or broken parts, damaged electrical, natural and operation, loose steel nuts on the suspension, nuts or bolts, damaged or missing electrical components. OPERATOR'S CAB HYDRAULIC FLUID, HOSES AND TUBING - Check fluid level and add if required. Check for leaks and add if needed. Replace as required. FRONT DRIVE TRANSMISSION (CONTINUOUS Wheel Machines Only) - Check fluid level and add if required. REAR DRIVE TRANSMISSION (SPINNING Wheel Machines, BAWD, BAWD or BAWD) - Check for correct operating pressure. WHEEL NUTS/ TRACK DRIVE SPACERS - Check for looseness and tighten as needed. TRACK TENSION (Track Machines Only) - Check tension and adjust as needed. STARTER MOTOR SHOCK ABSORBER MOUNTS - Inspect for damage, if equipped. BATTERY - Check battery for damage, add water, cables, clean cells and electrolyte level. Add distilled water as needed. <p>STARTUP PROCESSES</p> <ul style="list-style-type: none"> STEERING LEVER PIVOTS - Lubricate with 100 weight oil (non-Lubrication). (Tracked) ICE PINS (AWD Machines Only) - Lubricate with multi-purpose 100 weight grease. FRONT DRIVE TRANSMISSION (AWD) - Check for wear or damage. (AWD Machines Only) - Inspect if equipped. REAR DRIVE TRANSMISSION (AWD) - Check for wear or damage. (AWD Machines Only) - Inspect if equipped. OTHER DRIVE BELTS (AWD) - Check for wear, cracks, fraying, and all conditions. If equipped, check for proper fit and tension. Adjust or replace as needed. BOS - Check function of Lift Arm System control. <p>OPERATOR'S CAB</p> <ul style="list-style-type: none"> HYDRAULIC/HYDROSTATIC SYSTEM - Check fluid. Review correct level for unit. EXHAUST SYSTEM - Check for leaks. OPERATOR'S CAB FRONT DRIVE TRANSMISSION - Replace if needed. FRONT DRIVE TRANSMISSION (AWD) - Replace if needed. TRACK TENSION (AWD) - Replace if needed. FRONT DRIVE TRANSMISSION (AWD) - Replace if needed. <p>NOTES:</p> <ul style="list-style-type: none"> Replace alternator sooner if low voltage starting indicator turns on for more than 3 minutes after battery is fully charged. Service of first 20 hours, then as scheduled. See Operator's Manual for more information on specific maintenance procedures and intervals. See applicable service manual for your model. <p>SEE OPERATOR'S & MAINTENANCE MANUAL FOR MORE INFORMATION AND INSTRUCTIONS.</p>	<p>GENERAL LUBRICATION DIAGRAMS</p>
--	--	--

Maintenance work must be done at regular intervals. Failure to do so will result in excessive wear and early failures. The Service Schedule (above) is a guide for correct maintenance of the Bobcat loader. It is located inside the rear door of the loader.

Daily Inspection and Maintenance Checklist

- Engine Oil Level
- Hydraulic/Hydrostatic Fluid Level
- Engine Air Filter, Check System for Damage or Leaks
- Engine Coolant System, Check System for Damage or Leaks
- Operator Cab and Cab Mounting Hardware
- Seat Belt
- Seat Bar and Control Interlocks
- Grease Pivot Pins (Lift Arms, Bob-Tach, Cylinders, Bob-Tach Wedges)
- Tracks, Check for Wear or Damage
- Fuel Filter, Remove Trapped Water
- Loose or Broken Parts, Repair or Replace as Necessary
- Lift Arm Support Device. Replace if Damaged
- Bobcat Interlock Control System (BICS)

WARNING

Operator must have instructions before running the machine. Untrained operators can cause injury or death.

W-2001-0596

NOTE: Fluids such as engine oil, hydraulic fluid, coolant, etc. must be disposed of in an environmentally safe manner. Some regulations require that certain spills and leaks on the ground must be cleaned in a specific manner. See local, state and federal regulations for correct disposal.

PRE-STARTING PROCEDURES

Before Starting The Engine

Figure OI-43



Use the bucket or attachment steps, grab handles and safety treads (on the loader lift arms and frame) to get on and off the loader [Figure OI-43]. Do not jump.

Safety treads are installed on the Bobcat loader to provide a slip resistant surface for getting on and off the loader.

Keep safety treads clean and replace when damaged. Replacement treads are available from your Bobcat dealer.

Read and understand the Operation & Maintenance Manual and the Operator's Handbook (Item 1) [Figure OI-43] before operating the loader.

The Operation & Maintenance Manual and other manuals can be kept in a container (Item 2) [Figure OI-43] provided behind the operator seat.

WARNING

Instructions are necessary before operating or servicing machine. Read and understand the Operation & Maintenance Manual, Handbook and signs (decals) on machine. Follow warnings and instructions in the manuals when making repairs, adjustments or servicing. Check for correct function after adjustments, repairs or service. Untrained operators and failure to follow instructions can cause injury or death.

W-2003-0199

Figure OI-44

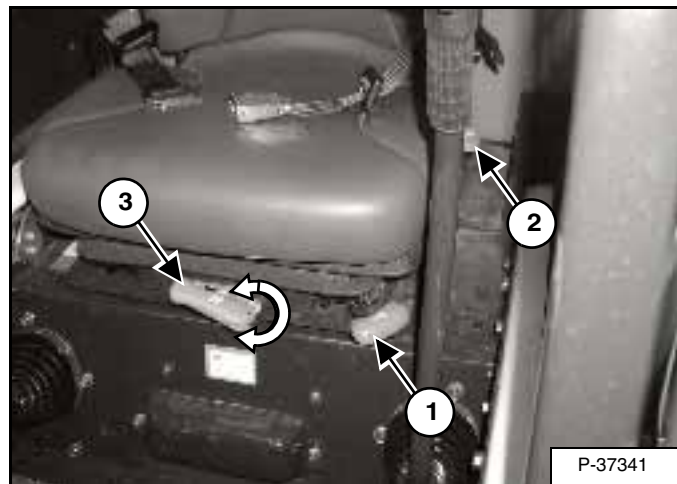

Suspension Seat - Release the lever (Item 1) [Figure OI-44] to adjust the seat distance from the levers and footrests

Release the lever (Item 2) [Figure OI-44] to adjust the angle of the seat back.

Turn the lever (Item 3) [Figure OI-44] to adjust the seat cushion for weight of the operator.

PRE-STARTING PROCEDURE (CONT'D)

Before Starting The Engine (Cont'd)

Figure OI-45

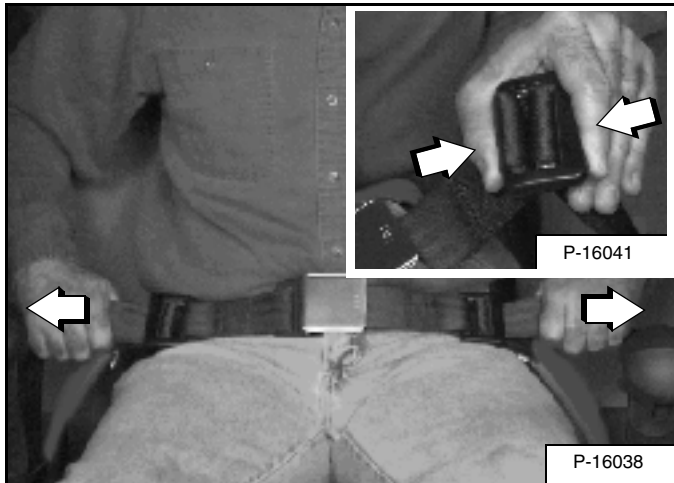

Squeeze both seat belt adjusters to release and lengthen each half of the seat belt [Figure OI-45].

Fasten the seat belt.

Pull the ends of the belt through the belt adjusters so that the seat belt is snug and the buckle is centered between your hips [Figure OI-45].

Figure OI-46

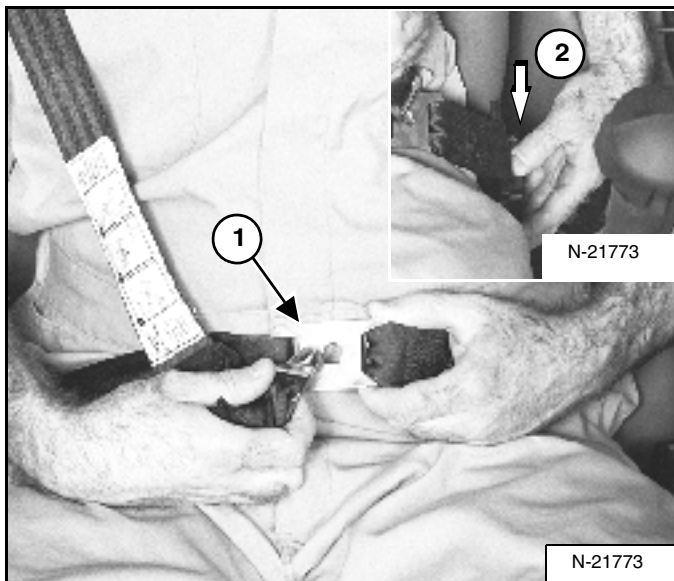

3-Point Restraint - (Option) Connect the shoulder belt to the lap belt (Item 1) [Figure OI-46]. Pull the lap belt across to the left side of the seat (Item 2) [Figure OI-46] and fasten.

The shoulder belt must be positioned over your right shoulder and lap belt over your lower hips [Figure OI-46].

IMPORTANT

Check the seat belt and shoulder belt retractors for correct operation.

Keep retractors clean and replace as necessary.

I-2199-0400

Figure OI-47



Lower the seat bar and engage the parking brake [Figure OI-47].

Put the foot pedals or hand controls in neutral position.

NOTE: Keep your hands on the steering levers and your feet on the foot pedals (or footrests) while operating the loader.

! WARNING

AVOID INJURY OR DEATH

When operating the machine:

- Keep the seat belt fastened snugly.
- The seat bar must be lowered.

Keep your feet on the pedal controls or footrests and hands on steering levers.

W-2261-0799

STARTING THE ENGINE (STANDARD PANEL, KEY SWITCH)

Starting Procedure

! WARNING

AVOID INJURY OR DEATH

- Engines can have hot parts and hot exhaust gas. Keep flammable material away.
- Do not use machines in atmosphere containing explosive gas.

W-2051-1086

Perform the PRE-STARTING PROCEDURE, (See PRE-STARTING PROCEDURES on Page OI-25).

Figure OI-48



Set the engine speed control to the 1/2 speed position [Figure OI-48].

Figure OI-49

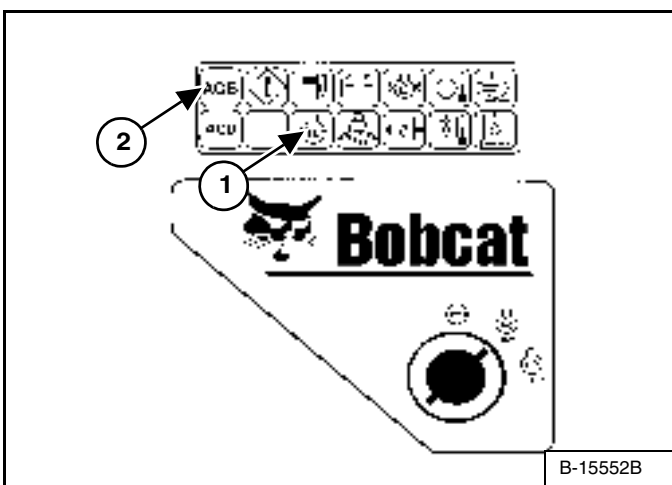

Turn the key switch to RUN [Figure OI-49]. The indicator lights on the right instrument panel [Figure OI-49] will come ON briefly and the Instrument Panel/monitoring system will do a self test.

If the temperature is cold, the intake air heater will automatically cycle. The Icon light (Item 1) [Figure OI-49] will be ON and the cycle time remaining will show in the hour meter.

When the Icon light goes OFF, turn the key switch to START [Figure OI-49].

NOTE: If equipped, make sure both hand controls (ACS) or Joysticks (SJC) are in the neutral position before starting the engine. Do not move the levers or joysticks from the neutral position when turning the key to RUN or START [Figure OI-49].

If controls are moved:

a. The neutral position for the hydraulic valve spool and hand control may not be correctly calibrated. This can result in slight movement of the lift or tilt hydraulic cylinders when the hand control lever is returned to the neutral position after start-up.

OR

b. ACS indicator light (Item 2) [Figure OI-49] on right instrument panel will be ON.

If either condition occurs, return key to STOP. Put the controls in neutral position and re-start engine.

Release the key when the engine starts. It will return to the RUN position.

STARTING THE ENGINE (STD. PANEL, KEY SWITCH) (CONT'D)

Starting Procedure (Cont'd)

Figure OI-50

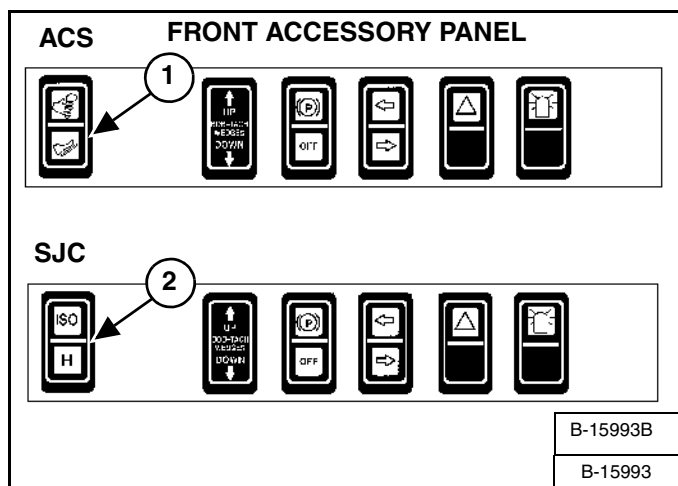

(ACS) Select hand control or foot pedal operation (Item 1)
[Figure OI-50].

OR

(SJC) Select 'ISO' or 'H' Control Pattern (Item 2)
[Figure OI-50].

Figure OI-51

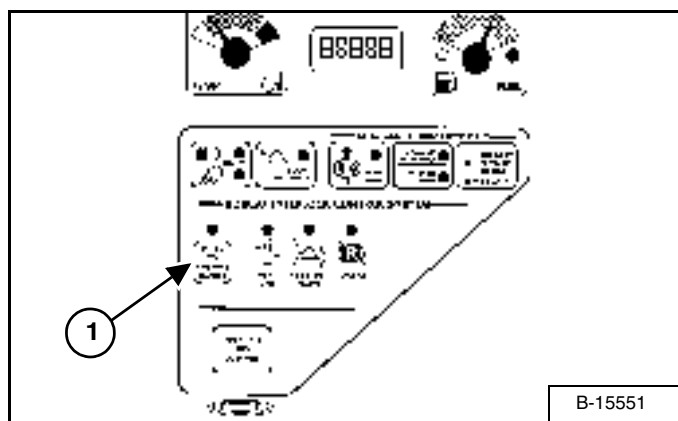

Press the PRESS TO OPERATE LOADER Button (Item 1)
[Figure OI-51] to activate the BICS system and to perform
hydraulic and loader functions. (See Cold Temperature
Starting on Page OI-30.)

NOTE: (SJC) The pending mode will flash which will indicate PRESS TO OPERATE LOADER is required. The light will flash when key is ON and continue to flash until the PRESS TO OPERATE LOADER button is pressed and thereafter it will light solid. If the mode (ISO/H) is changed while driving, the active mode will be solid and the pending mode will flash. When operation of the machine is returned to neutral, the active mode will then turn off and the pending mode will continue to flash until the PRESS TO OPERATE LOADER button is pressed.

STARTING THE ENGINE (DELUXE PANEL, KEYLESS START)

Starting Procedure

! WARNING

AVOID INJURY OR DEATH

- Engines can have hot parts and hot exhaust gas. Keep flammable material away.
- Do not use machines in atmosphere containing explosive gas.

W-2051-1086

Perform the PRE-STARTING PROCEDURE, (See PRE-STARTING PROCEDURES on Page OI-25).

Figure OI-52

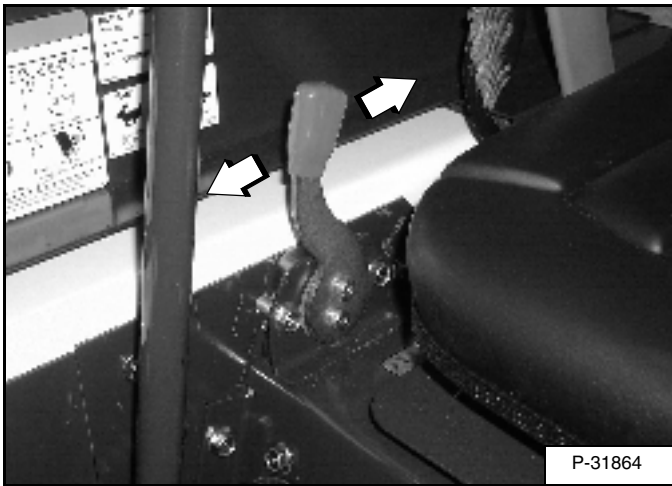

Set the engine speed control at the 1/2 speed position [Figure OI-52].

NOTE: Loaders with Deluxe Instrument Panel have a permanent, randomly generated Master Password set at the factory. Your loader will be assigned an Owner Password. Your dealer will provide you with this password. Change the password to one that you will easily remember to prevent unauthorized use of your loader. (See DELUXE INSTRUMENT PANEL SETUP on Page SA-9.) Keep your password in a safe place for future needs.

Figure OI-53

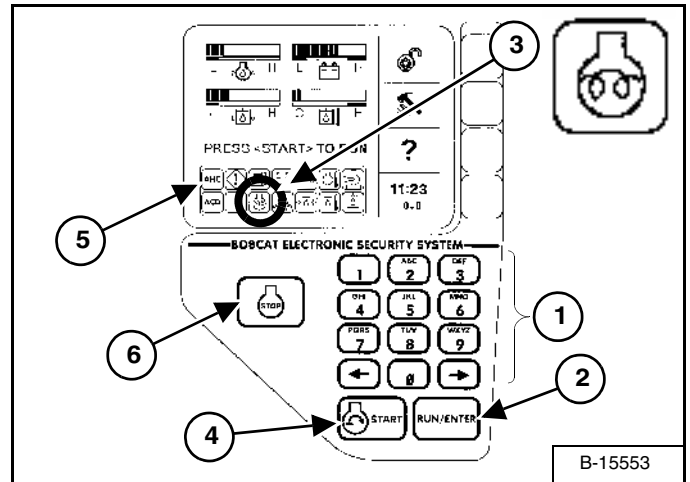

Use the numeric keypad (Item 1) [Figure OI-53] to enter the password, then press the RUN / ENTER Button (Item 2) [Figure OI-53].

If the temperature is cold, the intake air heater will automatically cycle and the Icon (Item 3) [Figure OI-53] will be ON.

When the Icon light goes OFF, press the START Button (Item 4) [Figure OI-53]. Release the button when the engine starts.

NOTE: If equipped, make sure both hand controls (ACS) or Joysticks (SJC) are in the neutral position before starting the engine. Do not move the levers or joysticks from the neutral position when attempting to start the engine.

If controls are moved:

- a. The neutral position for the hydraulic valve spool and hand control may not be correctly calibrated. This can result in slight movement of the lift or tilt hydraulic cylinders when the hand control lever is returned to the neutral position after start-up.

OR

- b. ACS indicator light (Item 5) [Figure OI-53] on right instrument panel will be ON.

If either condition occurs, return key to STOP. Put the controls in neutral position and re-start the engine.

STARTING THE ENGINE (DELUXE PANEL, KEYLESS START (CONT'D))

Starting Procedure (Cont'd)

Figure OI-54

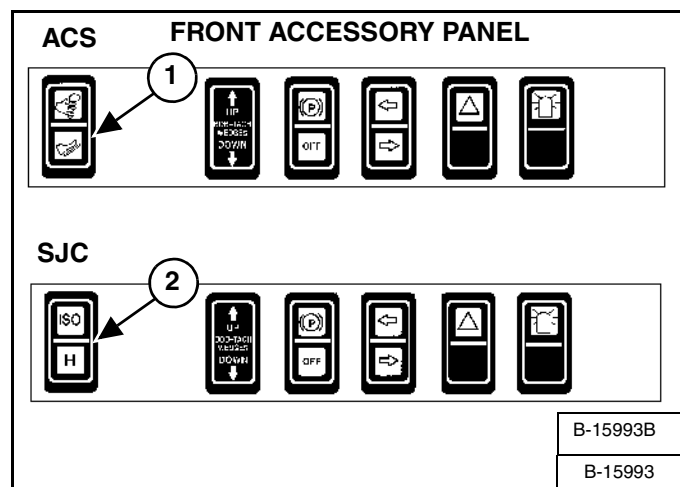

(ACS) Select hand control or foot pedal operation (Item 1) [Figure OI-54].

OR

(SJC) Select 'ISO' or 'H' Control Pattern (Item 2) [Figure OI-54].

Figure OI-55

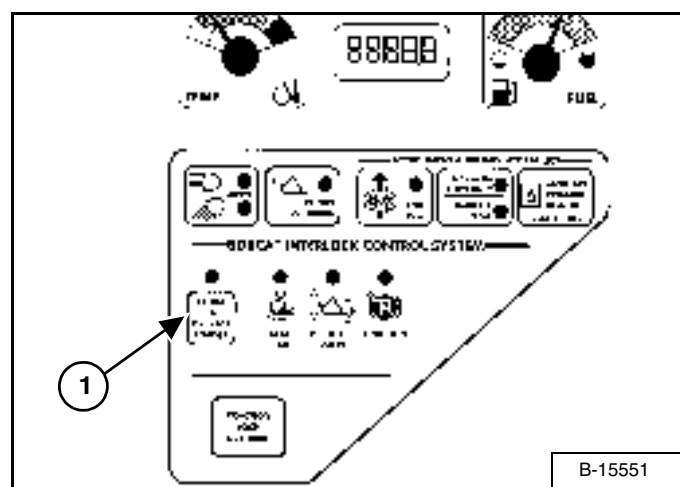

Press the PRESS TO OPERATE LOADER Button (Item 1) [Figure OI-55] to activate the BICS system and to perform hydraulic and loader functions. (See also Cold Temperature Starting).

NOTE: (SJC) The pending mode will flash which will indicate PRESS TO OPERATE LOADER is required. The light will flash when key is ON and continue to flash until the PRESS TO OPERATE LOADER button is pressed and thereafter it will light solid. If the mode (ISO/H) is changed while driving, the active mode will be solid and the pending mode will flash. When operation of the machine is returned to neutral, the active mode will then turn off and the pending mode will continue to flash until the PRESS TO OPERATE LOADER button is pressed.

Cold Temperature Starting

If the temperature is below freezing, perform the following to make starting the engine easier:

- Replace the engine oil with the correct type and viscosity for the anticipated starting temperature. (See ENGINE LUBRICATION SYSTEM on Page PM-21).
- Make sure the battery is fully charged.
- Install an engine heater, available from your Bobcat loader dealer.

NOTE: The LCD of the Deluxe Panel may not be immediately visible when the temperature is below -26 degrees C (-15 degrees F). It may take 30 seconds to several minutes for the Display Panel to warm up. All systems remain monitored even when the display is off.

WARMING THE HYDRAULIC / HYDROSTATIC SYSTEM

Warming Procedure

IMPORTANT

When the temperature is below -30°C (-20°F), hydrostatic oil must be warmed before starting. The hydrostatic system will not get enough oil at low temperatures and will be damaged. Park the machine in an area where the temperature will be above -18°C (0°F) if possible.

I-2007-1285

Let the engine run at least 5 minutes to warm the engine and hydrostatic fluid before operating the loader.

Figure OI-56

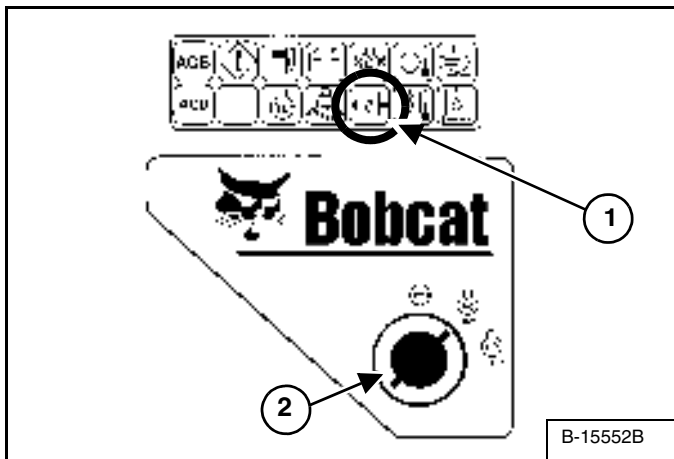
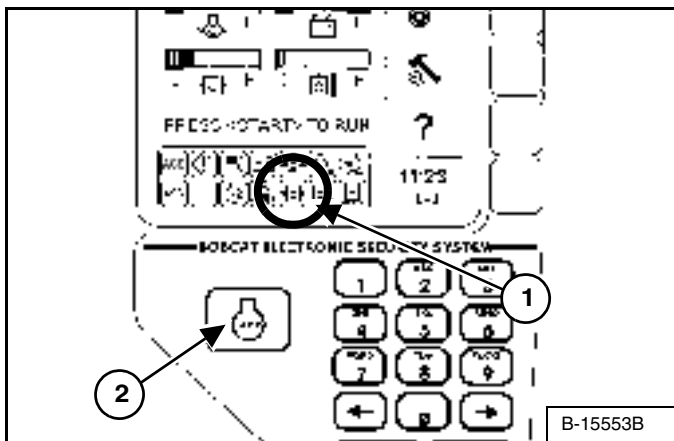

Figure OI-57



If the Fluid Pressure Icon (Item 1) [Figure OI-56] (Standard Panel) or [Figure OI-57] (Deluxe Panel) comes ON when operating the loader (cold), more warm up time is needed.

STOPPING THE ENGINE

Stopping Procedure

Figure OI-58

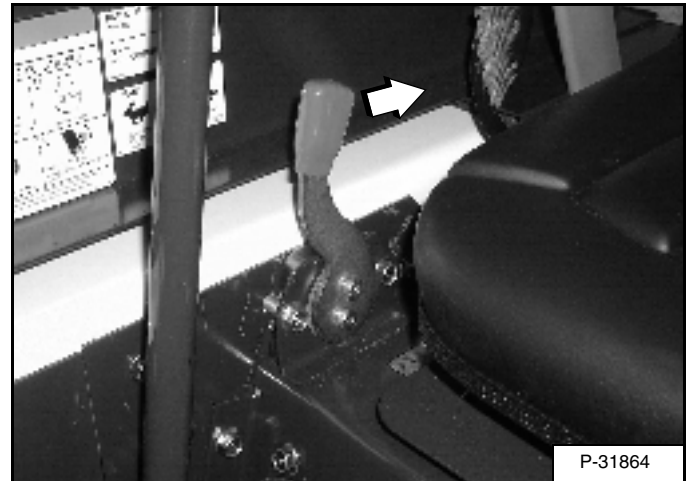

Pull the engine speed control fully backward [Figure OI-58] to decrease the engine speed.

Let the engine run at idle speed for 5 minutes to let the turbocharger cool before stopping the engine.

IMPORTANT

After a full load operation, allow the engine to run at idle speed for 5 minutes before stopping the engine.

Failure to do so can result in premature failure of the turbocharger.

I-2214-0402

Turn the key switch [Figure OI-56] to the STOP position (Standard Panel) or press the STOP Button [Figure OI-57] (Deluxe Panel).

MONITORING THE DISPLAY PANEL

Figure OI-59

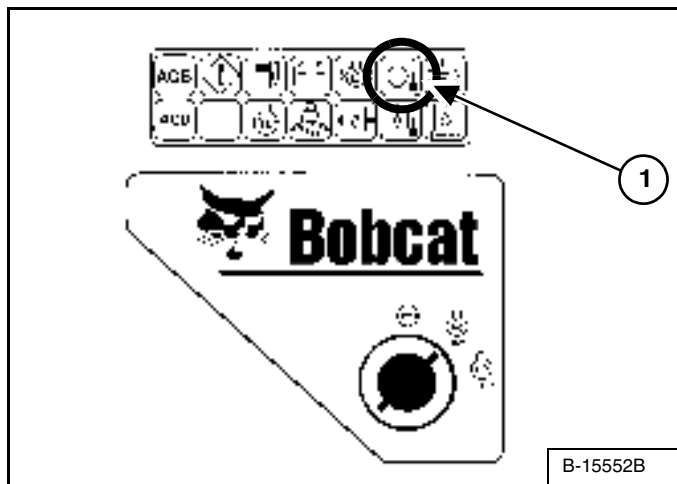
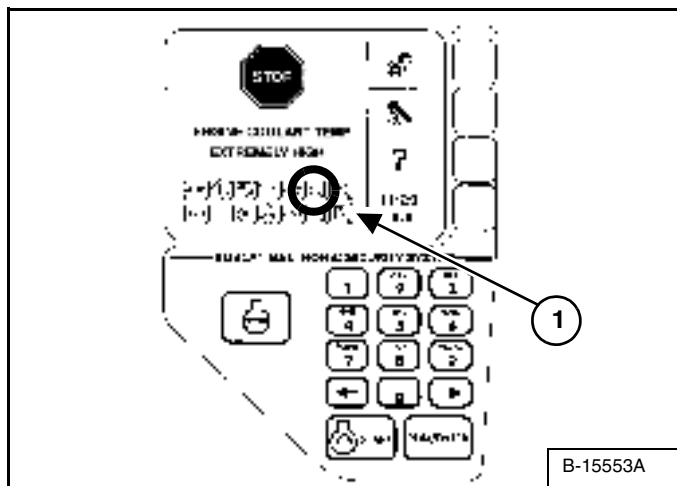

Figure OI-60



After the engine is running, frequently monitor the right instrument panel [Figure OI-59] (Standard Panel) and [Figure OI-60] (Deluxe Panel) for error conditions.

The associated icon will be ON if there is an error condition.

EXAMPLE: Engine Coolant Temperature is High

Standard Panel

The Engine Temperature Icon (Item 1) [Figure OI-59] will be ON.

Press and hold LIGHTS Button for 2 seconds. One of the following SERVICE CODES will be displayed.

- 08-10 Engine Coolant Temperature High
- 08-11 Engine Coolant Temperature Very High

Deluxe Panel

The Engine Temperature Icon (Item 2) [Figure OI-60] will be ON.

The SERVICE CODE will be in the hourmeter/code display (See left instrument panel).

In addition, the Deluxe Panel display screen will describe the extreme condition that can cause damage to the engine or loader systems [Figure OI-60].

WARNING and SHUTDOWN

When a WARNING condition exists, the associated Icon light will come ON and there will be 3 beeps from the alarm. Be aware that, if this condition is allowed to continue, there may be damage to the engine or loader hydraulic systems.

When a SHUTDOWN condition exists, the associated Icon light will come ON and there will be a continuous beep from the alarm and the monitoring system will automatically stop the engine in 10 seconds. The engine can be restarted to move or relocate the loader.

The SHUTDOWN feature is associated with the following Icons:

- General Warning
- Engine Oil Pressure
- Engine Coolant Temperature
- Hydraulic Oil Temperature
- Hydrostatic Charge Pressure

Whenever **STOP** appears on the display screen, lower the lift arms all the way, put the attachment flat on the ground and stop the engine to prevent damage to the engine or loader systems.

ATTACHMENTS AND BUCKETS

Selecting The Correct Bucket

NOTE: Warranty is void if non-approved attachments are used on the Bobcat loader.

WARNING

Never use attachments or buckets which are not approved by Bobcat Company. Buckets and attachments for safe loads of specified densities are approved for each model. Unapproved attachments can cause injury or death.

W-2052-0500

The dealer can identify, for each model loader, the attachments and buckets approved by Bobcat. The buckets and attachments are approved for Rated Operating Capacity and for secure fastening to the Bob-Tach.

The Rated Operating Capacity for this loader is shown on a decal in the operator cab. (See Fluid Capacities on Page SPEC-6.)

The Rated Operating Capacity is determined by using a standard dirt bucket, and material of normal density, such as dirt or dry gravel. If longer buckets are used, the load center moves forward and reduces the Rated Operating Capacity. If very dense material is loaded, the volume must be reduced to prevent overloading.

Figure OI-61

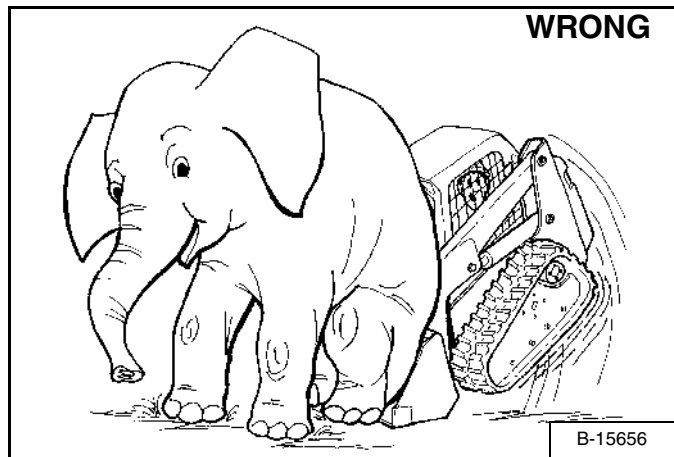

Exceeding the Rated Operating Capacity [Figure OI-61] can cause the following problems:

- Steering the loader may be difficult.
- Tracks will wear faster.
- There will be a loss of stability.
- The life of the Bobcat loader will be reduced.

Use the correct bucket size for the type and density of material being handled. For safe handling of materials and avoiding machine damage, the attachment (or bucket) should handle a full load without going over the Rated Operating Capacity for the loader. Partial loads make steering more difficult.

ATTACHMENTS AND BUCKETS (CONT'D)

Pallet Forks

Figure OI-62

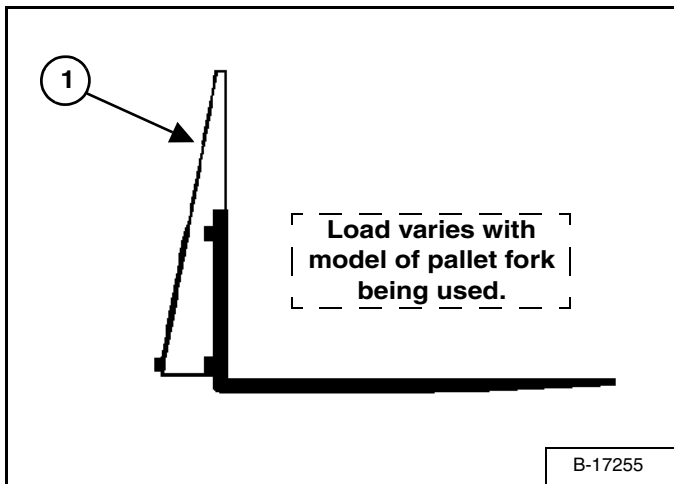

If a pallet fork attachment is used, the load center moves forward and reduces the Rated Operating Capacity.

The maximum load to be carried when using a pallet fork is shown on a decal located on the pallet fork frame (Item 1) [Figure OI-62].

WARNING

AVOID INJURY OR DEATH

Do not exceed rated operating capacity. Excessive load can cause tipping or loss of control.

W-2053-0887

See your Bobcat Dealer for more information about pallet fork inspection, maintenance and replacement. See your Bobcat loader dealer for Rated Operating Capacity when using a pallet fork and for other available attachments.

Hand Lever Bob-Tach - Installing The Bucket Or Attachment

The Bob-Tach is used for fast changing of buckets and attachments. See the appropriate Attachment Operation & Maintenance Manual to install other attachments.

Figure OI-63

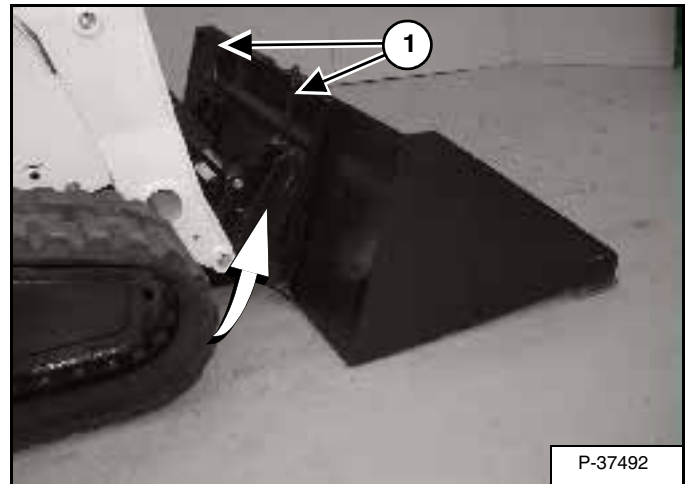

Pull the Bob-Tach levers all the way up (Item 1) [Figure OI-63].

Enter the loader and perform the PRE-STARTING PROCEDURE (See PRE-STARTING PROCEDURES on Page OI-25).

Lower the lift arms and tilt the Bob-Tach forward.

Drive the loader forward until the top edge of the Bob-Tach is completely under the top flange of the bucket [Figure OI-63] (or other attachment). Be sure the Bob-Tach levers do not hit the bucket.

Figure OI-64

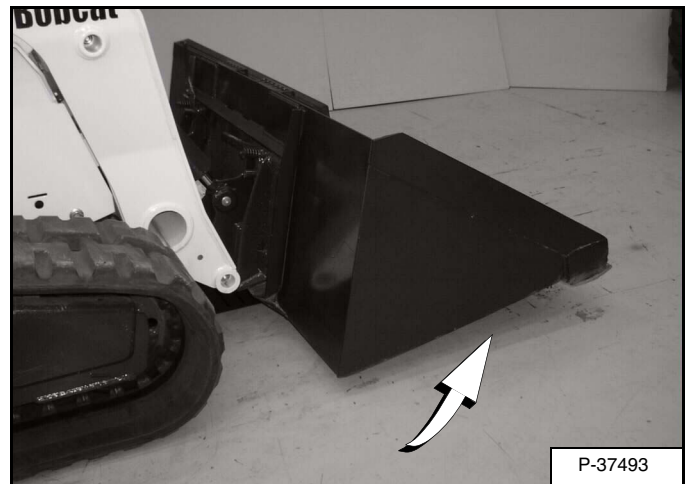

Tilt the Bob-Tach backward until the cutting edge of the bucket (or other attachment) is slightly off the ground [Figure OI-64].

Stop the engine and exit the loader.

ATTACHMENTS AND BUCKETS (CONT'D)

Hand Lever Bob-Tach - Installing The Bucket Or Attachment (Cont'd)

! WARNING

Before you leave the operator's seat:

- Lower the lift arms, put the attachment flat on the ground.
- Stop the engine.
- Engage the parking brake.
- Raise seat bar
- *(Foot Pedal Controls Only)* Move pedals until both lock.
- *(Advanced Control System (ACS))* Move the hydraulic controls to the **NEUTRAL POSITION** to make sure that both lift and tilt functions are deactivated.

The seat bar system must deactivate the lift and tilt control functions when the seat bar is up. Service the system if hand controls do not deactivate.

- *(Selectable Joystick Control - SJC)* Move the joysticks to the **NEUTRAL POSITION** to make sure that travel and hydraulic functions are deactivated.

The seat bar system must deactivate these functions when the seat bar is up. Service the system if controls do not deactivate.

W-2463-0603

Figure OI-66

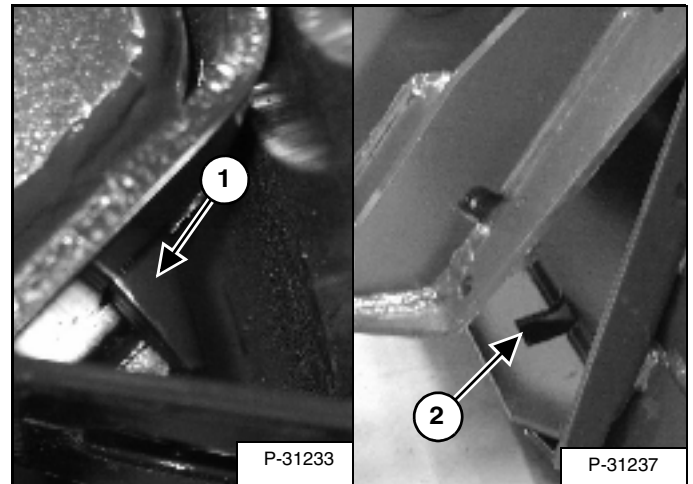

The wedges (Item 1) [Figure OI-66] must extend through the holes (Item 2) [Figure OI-66] in the mounting frame of the bucket (or other attachment), securely fastening the bucket to the Bob-Tach.

! WARNING

Bob-Tach wedges must extend through the holes in attachment. Levers must be fully down and locked. Failure to secure wedges can allow attachment to come off and cause injury or death.

W-2102-0588

Figure OI-65

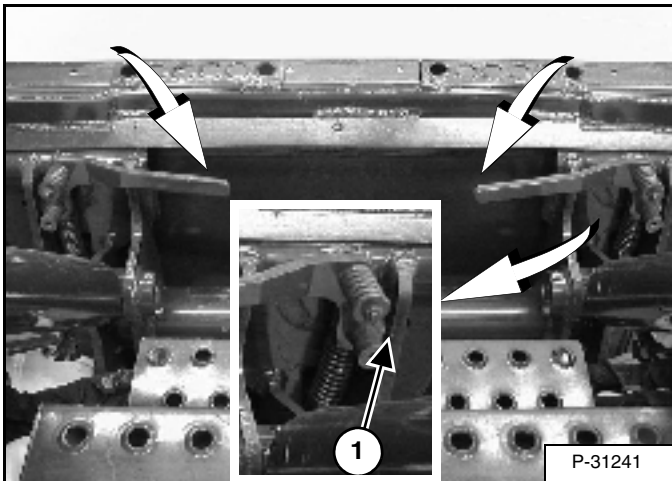

Push down on the Bob-Tach levers until they are fully engaged in the locked position (Item 1) [Figure OI-65] (wedges fully extended).

ATTACHMENTS AND BUCKETS (CONT'D)

Hand Lever Bob-Tach - Removing The Bucket Or Attachment

Lower the lift arms and put the attachment flat on the ground.

Raise the seat bar, unfasten the seat belt, set the parking brake and exit the loader.

If the attachment is hydraulically controlled, lower or close the hydraulic equipment. You may need to release hydraulic pressure before disconnecting the quick couplers (See also Releasing Hydraulic Pressure (Loader and Attachment) on Page OI-19).

! WARNING

Before you leave the operator's seat:

- Lower the lift arms, put the attachment flat on the ground.
- Stop the engine.
- Engage the parking brake.
- Raise seat bar
- *(Foot Pedal Controls)* Move pedals until both lock.
- *(Advanced Control System (ACS))* Move the hydraulic controls to the NEUTRAL POSITION to make sure that both lift and tilt functions are deactivated.

The seat bar system must deactivate the lift and tilt control functions when the seat bar is up. Service the system if hand controls do not deactivate.

- *(Selectable Joystick Control - SJC)* Move the joysticks to the NEUTRAL POSITION to make sure that travel and hydraulic functions are deactivated.

The seat bar system must deactivate these functions when the seat bar is up. Service the system if controls do not deactivate.

W-2463-0603

Figure OI-67

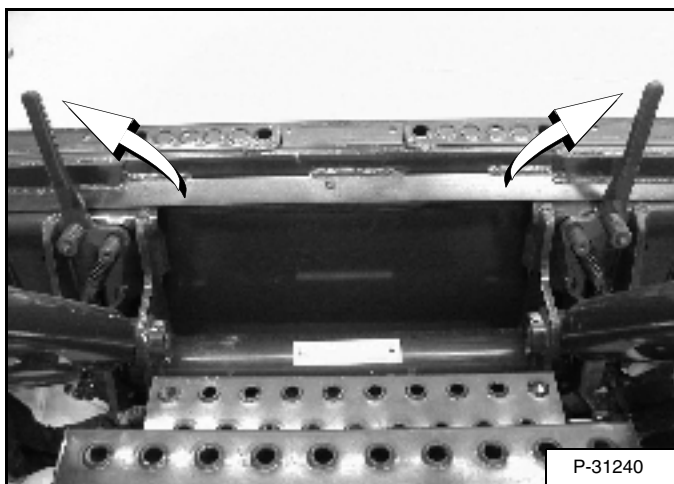

Pull the Bob-Tach levers [Figure OI-67] all the way up.

! WARNING

Bob-Tach levers have spring tension. Hold lever tightly and release slowly. Failure to obey warning can cause injury.

W-2054-1285

Enter the loader.

Perform the PRE-STARTING PROCEDURE (See PRE-STARTING PROCEDURES on Page OI-25).

Start the engine and release the parking brake.

Be sure the lift arms are all the way down. Tilt the Bob-Tach forward.

Figure OI-68

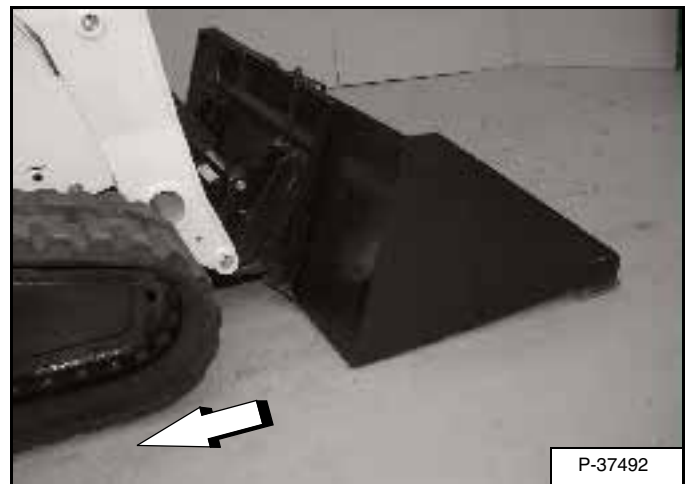

Move the loader backward, away from the bucket or attachment [Figure OI-68].

ATTACHMENTS AND BUCKETS (CONT'D)

Power Bob-Tach - Installing The Bucket Or Attachment

The Bob-Tach is used for fast changing of buckets and attachments. See the appropriate Attachment Operation & Maintenance Manual to install other attachments.

Perform the PRE-STARTING PROCEDURE (See also PRE-STARTING PROCEDURES on Page OI-25).

Lower the lift arms and tilt the Bob-Tach forward.

Figure OI-69

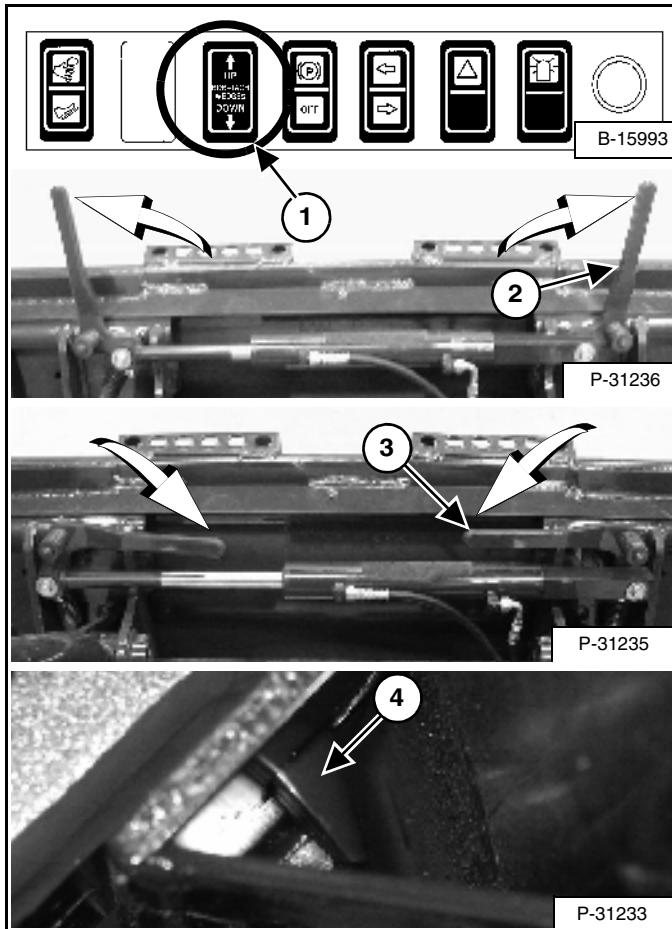

Push and hold BOB-TACH “WEDGES UP” switch (Item 1) [Figure OI-69] (Front Accessory Panel) until levers (Item 2) are in unlocked position (wedges fully raised).

NOTE: The Power Bob-Tach system has continuous pressurized oil to keep the wedges in the engaged position and prevent attachment disengagement. Because the wedges can slowly lower, the operator may need to re-activate the switch (WEDGES UP) when installing an attachment to be sure both wedges are fully raised before installing the attachment.

Figure OI-70

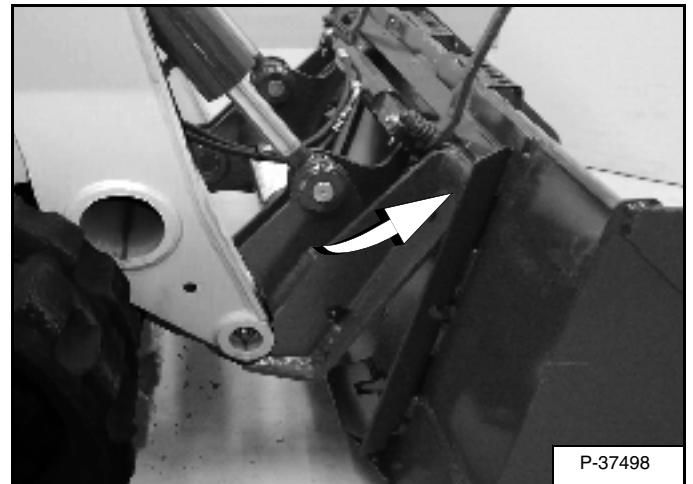

Drive the loader forward until the top edge of the Bob-Tach is completely under the top flange of the bucket [Figure OI-70] (or other attachment).

Figure OI-71

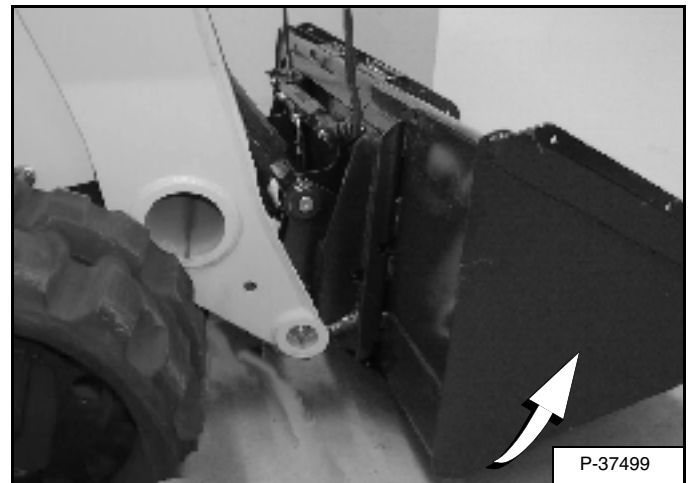

Tilt the Bob-Tach backward until the cutting edge of the bucket (or other attachment) is slightly off the ground [Figure OI-71].

Push and hold BOB-TACH “WEDGES DOWN” switch (Item 3) (Front Accessory Panel) [Figure OI-69] until levers (Item 3) are fully engaged in the locked position (wedges fully engaged).

The wedges (Item 4) [Figure OI-69] must extend through the holes in the mounting frame of the bucket (or other attachment), securely fastening the bucket to the Bob-Tach.

ATTACHMENTS AND BUCKETS (CONT'D)

Power Bob-Tach - Removing The Bucket Or Attachment

! WARNING

Bob-Tach wedges must extend through the holes in attachment. Levers must be fully down and locked. Failure to secure wedges can allow attachment to come off and cause injury or death.

W-2102-0588

Lower the lift arms and put the attachment flat on the ground.

If the attachment is hydraulically controlled, lower or close the hydraulic equipment before disconnecting the quick couplers (See also Releasing Hydraulic Pressure (Loader and Attachment) on Page OI-19).

! WARNING

Before you leave the operator's seat:

- Lower the lift arms, put the attachment flat on the ground.
- Stop the engine.
- Engage the parking brake.
- Raise seat bar
- *(Foot Pedal Controls)* Move pedals until both lock.
- *(Advanced Control System - ACS)* Move the hydraulic controls to the NEUTRAL POSITION to make sure that both lift and tilt functions are deactivated.

The seat bar system must deactivate the lift and tilt control functions when the seat bar is up. Service the system if controls do not deactivate.

- *(Selectable Joystick Control - SJC)* Move the joysticks to the NEUTRAL POSITION to make sure that travel and hydraulic functions are deactivated.

The seat bar system must deactivate these functions when the seat bar is up. Service the system if controls do not deactivate.

W-2463-0603

Figure OI-72

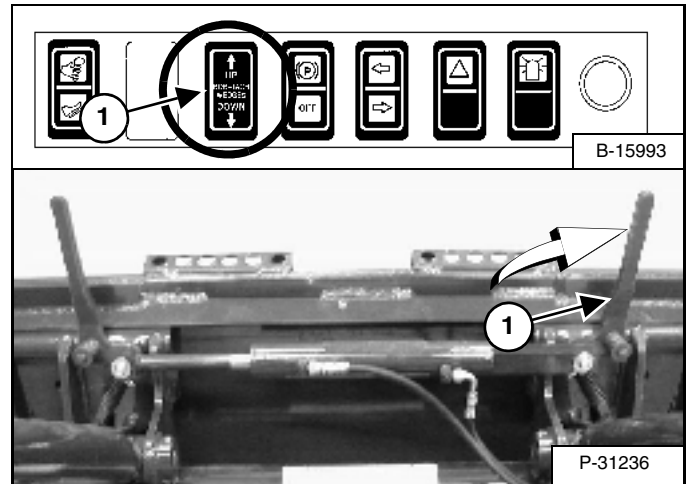

Push and hold the BOB-TACH "WEDGES UP" Switch (Front Accessory Panel) [Figure OI-72] until the wedges are fully raised.

Tilt the Bob-Tach forward.

Figure OI-73

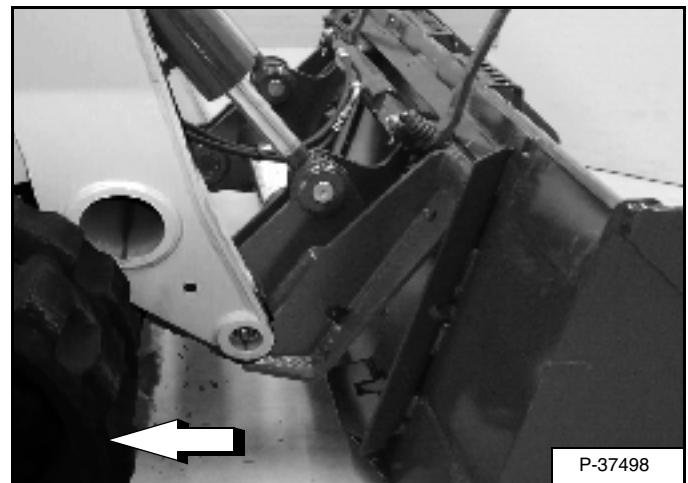

Move the loader backward, away from the bucket or attachment [Figure OI-73].

NOTE: The Power Bob-Tach system has continuous pressurized oil to keep the wedges in the engaged position and prevent attachment disengagement. Because the wedges can slowly lower, the operator may need to re-activate the switch (WEDGES UP) when installing an attachment to be sure both wedges are fully raised before installing the attachment.

OPERATING PROCEDURE

Operating With A Full Bucket

When operating on a public road or highway, always follow local regulations. For example: Slow Moving Vehicle Sign or direction signals may be required.

Always warm the engine and hydrostatic system before operating the loader.

IMPORTANT

Machines warmed up with moderate engine speed and light load have longer life.

I-2015-0284

Operate the loader with engine at full speed for maximum horsepower. Move the steering levers only a small amount to operate the loader slowly.

New operators must operate the loader in an open area without bystanders. Operate the controls until the loader can be handled at an efficient and safe rate for all conditions of the work area.

Figure OI-74

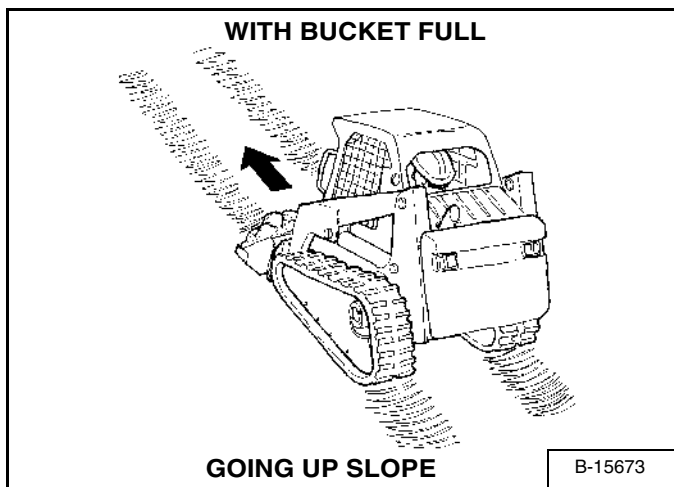
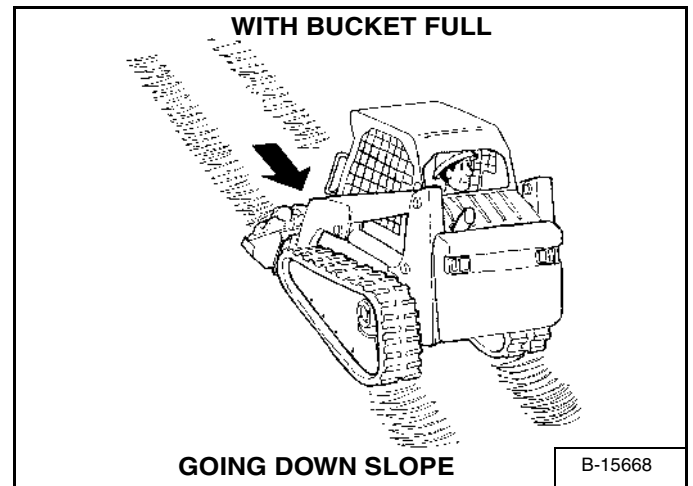

Figure OI-75



With a full bucket, go up or down the slope with the heavy end toward the top of the slope [Figure OI-74] and [Figure OI-75].

OPERATING PROCEDURE (CONT'D)

Operating With An Empty Bucket

Figure OI-76

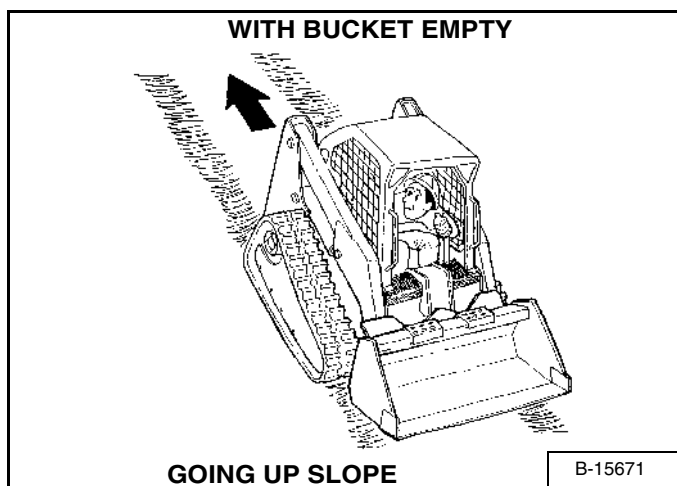
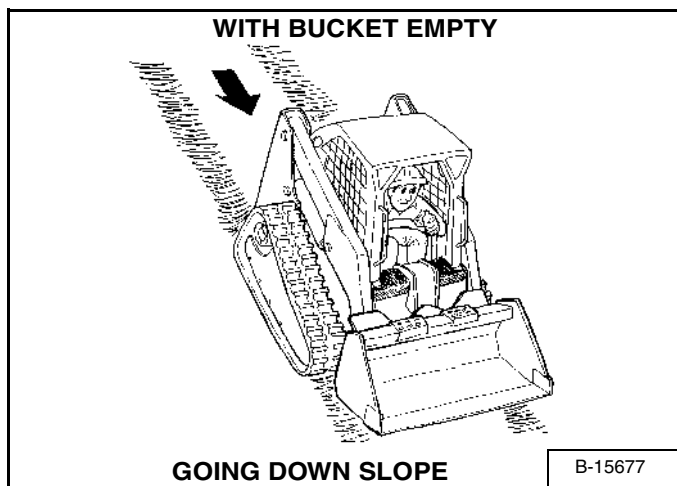

Figure OI-77



With an empty bucket, go down or up the slope with the heavy end toward the top of the slope [Figure OI-76] and [Figure OI-77].

Raise the bucket only high enough to avoid obstructions on rough ground.

WARNING

AVOID INJURY OR DEATH

- Keep the lift arms as low as possible.
- Do not travel or turn with the lift arms up.
- Turn on level ground.
- Go up and down slopes, not across them.
- Keep the heavy end of the machine uphill.
- Do not overload the machine.

Failure to obey warnings can cause the machine to tip or roll over and cause injury or death.

W-2018-1187

OPERATING PROCEDURE (CONT'D)

Compact Track Loader Operating Tips

Figure OI-78

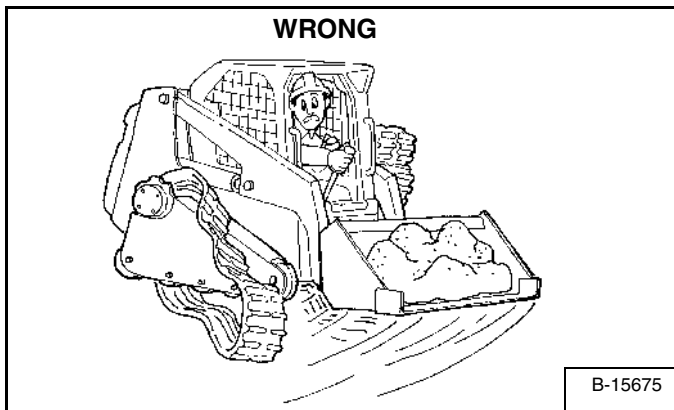

Correct track tension is important. If the tracks are too loose, they can easily derail. If they are too tight, they will wear faster and cause increased stress on the complete track carriage system.

Use a gradual turn (one lever farther forward than the other) instead of a fast turn (one steering lever forward, one backward) on asphalt or concrete surfaces to prevent reduced track life or derailing of tracks [Figure OI-78].

Figure OI-79

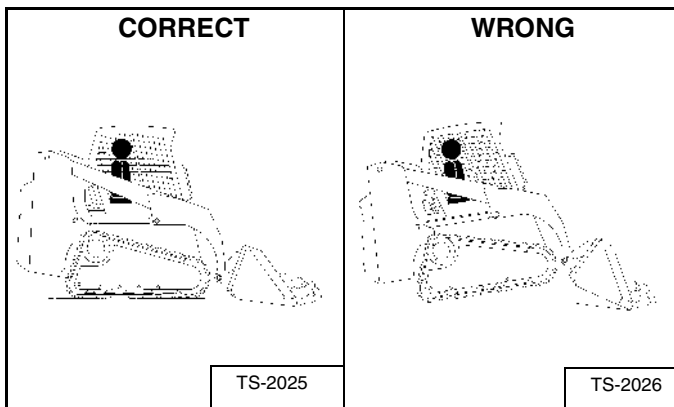

Keep the full length of the tracks in contact with the ground [Figure OI-79] for best traction. Raising the front end of the tracks off the ground [Figure OI-79] will reduce traction and cause increased track wear.

Figure OI-80

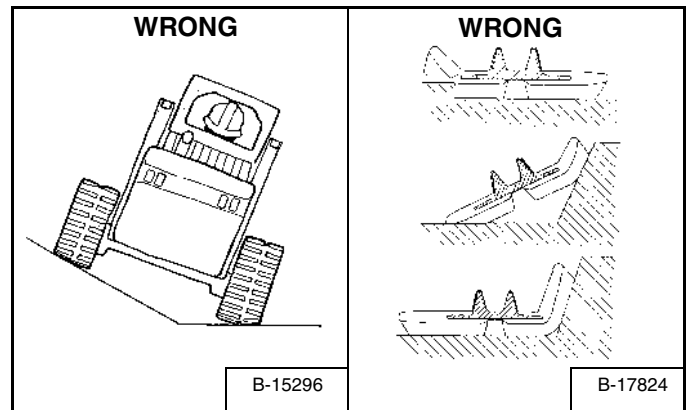

Go directly up or down a slope, not across the slope to prevent tracks from derailing.

Avoid operating the loader with one track on a slope and the other on flat ground [Figure OI-80] or with the edge of the track turned up against a curb or mound [Figure OI-80]. This can cause the tracks to derail, cracks in the edge of the tracks or cracks at the edges of the embedded metal.

Figure OI-81

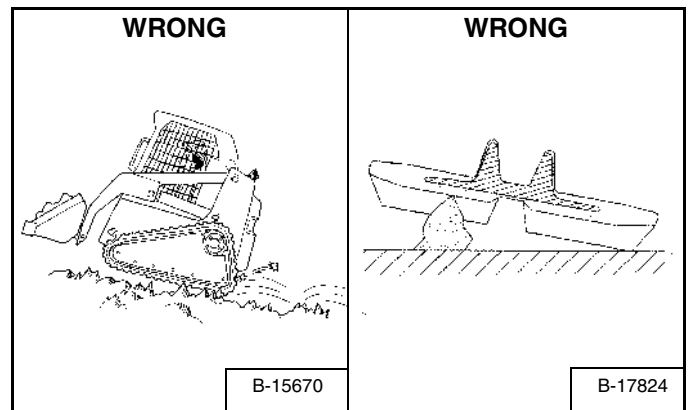

Avoid operating or turning on sharp objects such as jagged rocks or broken concrete. This will cause cuts on the lug surfaces of the tracks [Figure OI-81].

OPERATING PROCEDURE (CONT'D)

Foot Pedal Machines

Filling The Bucket:

Figure OI-82

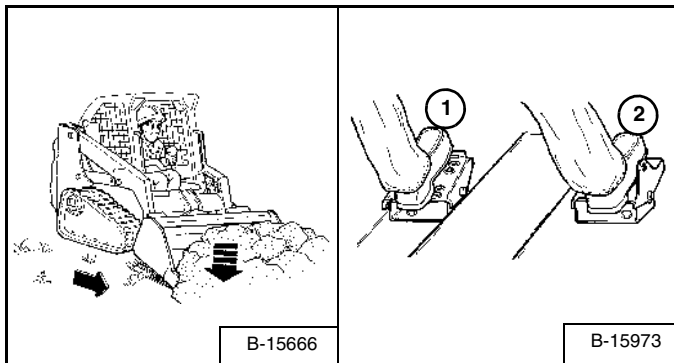
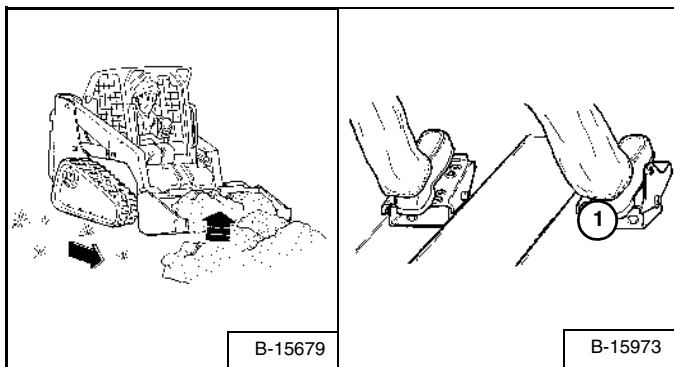

Figure OI-83



Lower the lift arms all the way (Item 1) [Figure OI-82].

Tilt the bucket forward (Item 2) [Figure OI-82] until the cutting edge of the bucket is on the ground.

Drive slowly forward into the material. Tilt the bucket backward (Item 1) [Figure OI-83] all the way when the bucket is full.

Drive backward away from the material.

! WARNING

Load, unload and turn on flat level ground. Do not exceed rated operating capacity shown on sign (decal) in cab. Failure to obey warnings can cause the machine to tip or roll over and cause injury or death.

W-2056-1187

Emptying The Bucket:

Figure OI-84

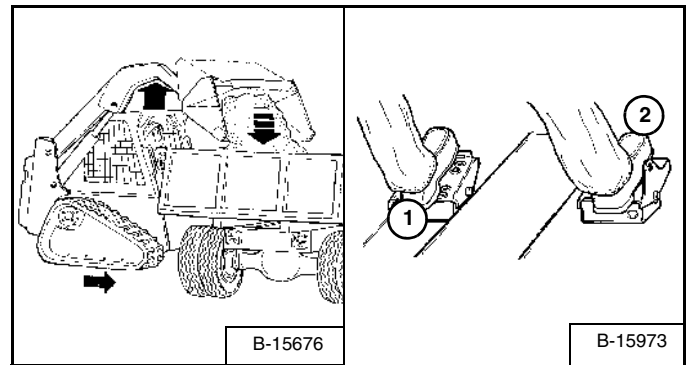

Keep the bucket low when moving to the area where you want to empty the bucket.

Raise the lift arms (Item 1) [Figure OI-84]. Level the bucket (Item 2) [Figure OI-84] while raising the lift arms to help prevent material from falling off the back of the bucket.

Drive forward slowly until the bucket is over the top of the truck box or bin.

Empty the bucket (Item 2) [Figure OI-84]. If all the material is near the side of the truck or bin, use the bucket tilt to move it to the other side.

! WARNING

Never dump over an obstruction, such as a post, that can enter the operator cab. The machine could tip forward and cause injury or death.

W-2057-0694

OPERATING PROCEDURE (CONT'D)

Foot Pedal Machines (Cont'd)

Leveling The Ground (Using Float Position):

Figure OI-85

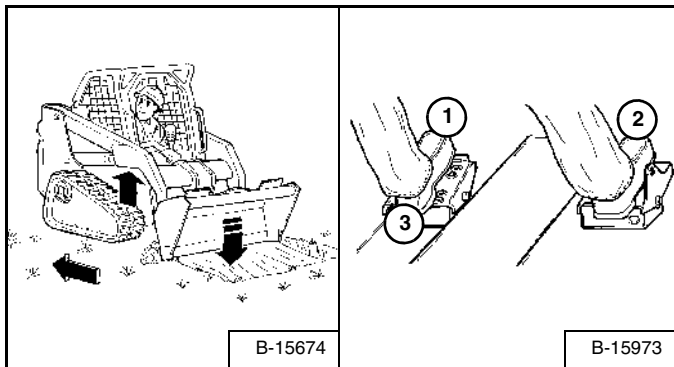

Put the lift arms in *float* position by pushing the pedal all the way forward (Item 1) [Figure OI-85] until the pedal is locked in the forward position.

Tilt the bucket forward (Item 2) [Figure OI-85] to change the position of the cutting edge of the bucket.

With the bucket tilted farther forward, there is more force on the cutting edge and more loose material can be moved.

Drive backward to level loose material.

Push the bottom of the lift pedal (Item 3) [Figure OI-85] to unlock the float position.

IMPORTANT

Never drive forward when the hydraulic control for lift arms is in float position.

I-2005-1285

Digging A Hole

Figure OI-86

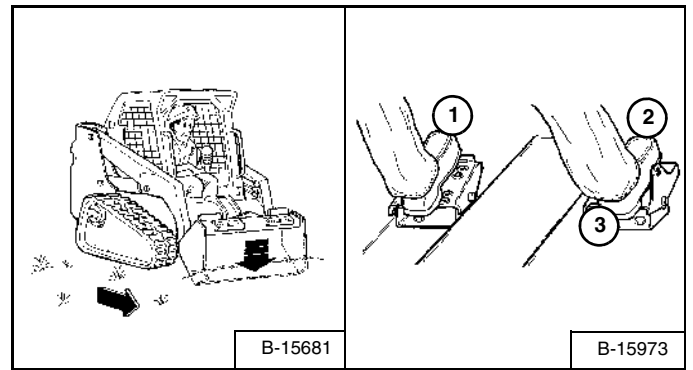

Lower the lift arms all the way (Item 1) [Figure OI-86]. Put the cutting edge of the bucket on the ground (Item 2) [Figure OI-86].

Drive forward slowly and continue to tilt the bucket down (Item 2) [Figure OI-86] until it enters the ground.

Raise the cutting edge a small amount (Item 3) [Figure OI-86] to increase traction and keep an even digging depth. Continue to drive forward until the bucket is full. When the ground is hard, raise and lower the cutting edge of the bucket (Items 2 & 3) [Figure OI-86] while driving forward slowly.

Tilt the bucket backward (Item 3) [Figure OI-86] as far as it will go when the bucket is full.

Filling The Hole

Figure OI-87

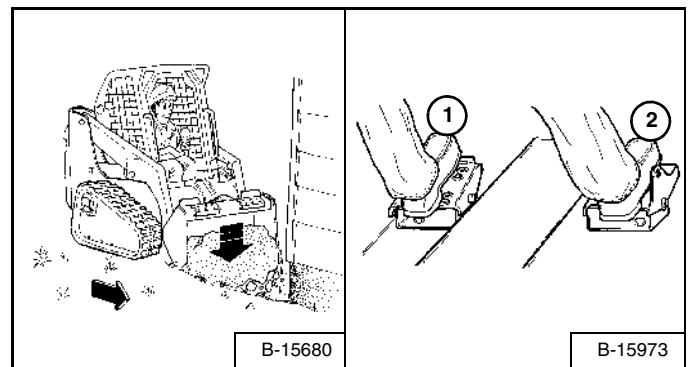

Lower the lift arms (Item 1) [Figure OI-87] and put the cutting edge of the bucket on the ground (Item 2) [Figure OI-87]. Drive forward to the edge of the hole to push the material into the hole.

Tilt the bucket forward (Item 2) [Figure OI-87] as soon as it is past the edge of the hole.

If necessary, raise the lift arms to empty the bucket.

OPERATING PROCEDURE (CONT'D)

Hand Control Machines (Includes ACS and SJC with H-Pattern Selected)

Filling The Bucket:

Figure OI-88

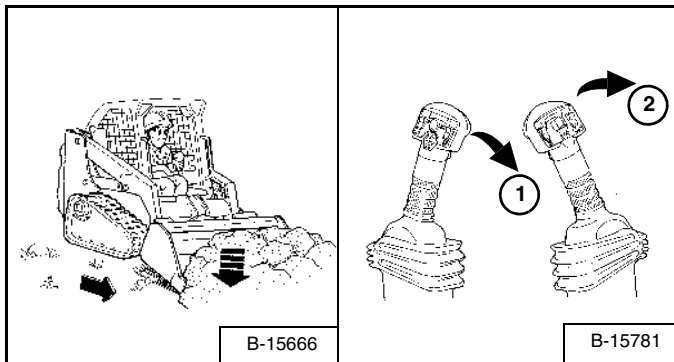
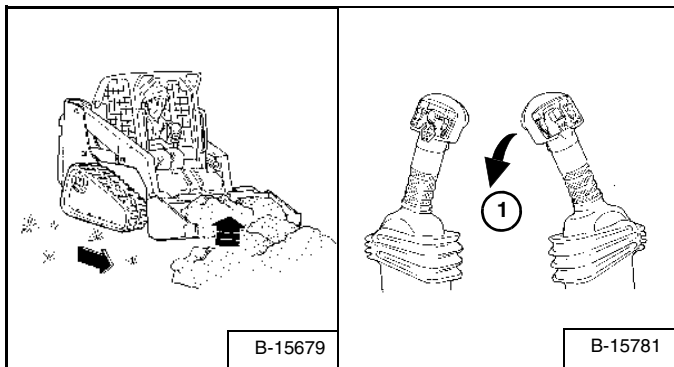

Figure OI-89



Lower the lift arms all the way (Item 1) [Figure OI-88].

Tilt the bucket forward (Item 2) [Figure OI-88] until the cutting edge of the bucket is on the ground.

Drive slowly forward into the material. Tilt the bucket backward (Item 1) [Figure OI-89] all the way when the bucket is full.

Drive backward away from the material.

! WARNING

Load, unload and turn on flat level ground. Do not exceed rated operating capacity shown on sign (decal) in cab. Failure to obey warnings can cause the machine to tip or roll over and cause injury or death.

W-2056-1187

Emptying The Bucket:

Figure OI-90

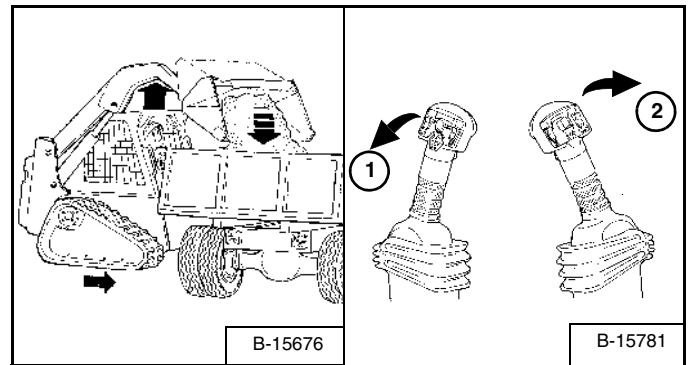

Keep the bucket low when moving to the area where you want to empty the bucket.

Raise the lift arms (Item 1) [Figure OI-90]. Level the bucket (Item 2) [Figure OI-90] while raising the lift arms to help prevent material from falling off the back of the bucket.

Drive forward slowly until the bucket is over the top of the truck box or bin.

Empty the bucket (Item 2) [Figure OI-90]. If all material is near the side of the truck or bin, use the bucket tilt to move it to the other side.

! WARNING

Never dump over an obstruction, such as a post, that can enter the operator cab. The machine could tip forward and cause injury or death.

W-2057-0694

OPERATING PROCEDURE (CONT'D)

Hand Control Machines (Includes ACS and SJC with H-Pattern Selected) (Cont'd)

Leveling The Ground (Using Float Position):

Figure OI-91

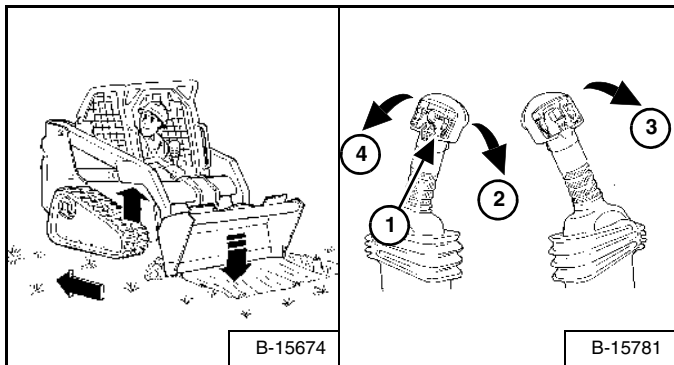

Press and hold the float button (Item 1) [Figure OI-91] while the lever is in neutral. While lowering the lift arms (Item 2) [Figure OI-91], release the float button.

Tilt the bucket forward (Item 3) [Figure OI-91] to change the position of the cutting edge of the bucket.

With the bucket tilted farther forward, there is more force on the cutting edge and more loose material can be moved.

Drive backward to level loose material.

To disengage float, press the float button again or raise the lift arms (Item 4) [Figure OI-91].

IMPORTANT

Never drive forward when the hydraulic control for lift arms is in float position.

I-2005-1285

Digging A Hole

Figure OI-92

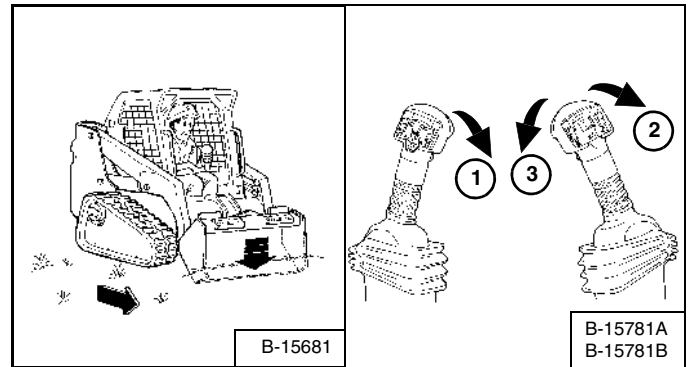

Lower the lift arms all the way (Item 1) [Figure OI-92]. Tilt the bucket forward (Item 2) [Figure OI-92] until the cutting edge of the bucket is on the ground.

Drive forward slowly and continue to tilt the bucket down (Item 2) [Figure OI-92] until it enters the ground.

Tilt the bucket backward a small amount (Item 3) [Figure OI-92] to increase traction and keep an even digging depth. Continue to drive forward until the bucket is full. When the ground is hard, raise and lower the cutting edge (Items 1 & 2) [Figure OI-92] while driving forward.

Tilt the bucket backward (Item 2) [Figure OI-92] as far as it will go when the bucket is full.

Filling The Hole

Figure OI-93

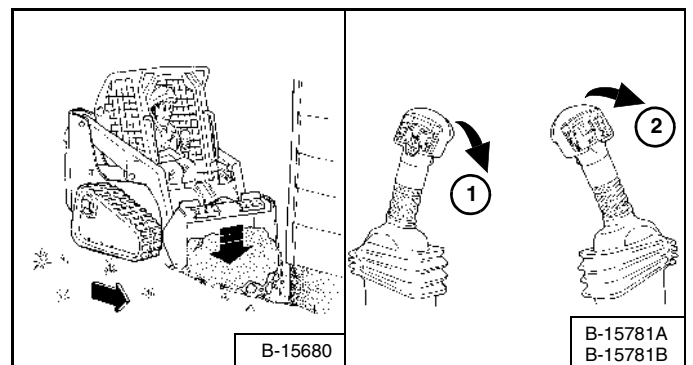

Lower the lift arms (Item 1) [Figure OI-93] and put the cutting edge of the bucket on the ground (Item 2) [Figure OI-93]. Drive forward to the edge of the hole to push the material into the hole.

Tilt the bucket forward (Item 2) [Figure OI-93] as soon as it is past the edge of the hole.

If necessary, raise the lift arms to empty the bucket.

OPERATING PROCEDURE (CONT'D)

Selectable Joystick Control (SJC) with 'ISO' Pattern Selected

Filling The Bucket:

Figure OI-94

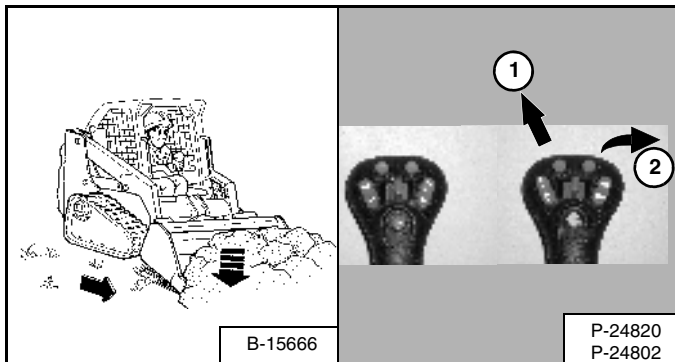
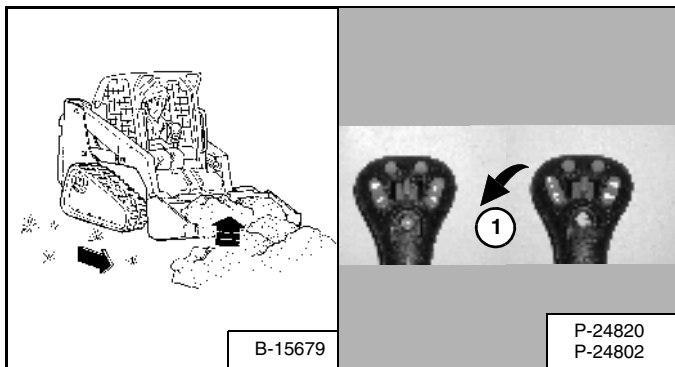

Figure OI-95



Lower the lift arms all the way (Item 1) [Figure OI-94].

Tilt the bucket forward (Item 2) [Figure OI-94] until the cutting edge of the bucket is on the ground.

Drive slowly forward into the material. Tilt the bucket backward (Item 1) [Figure OI-95] all the way when the bucket is full.

Drive backward away from the material.

! WARNING

Load, unload and turn on flat level ground. Do not exceed rated operating capacity shown on sign (decal) in cab. Failure to obey warnings can cause the machine to tip or roll over and cause injury or death.

W-2056-1187

Emptying The Bucket:

Figure OI-96

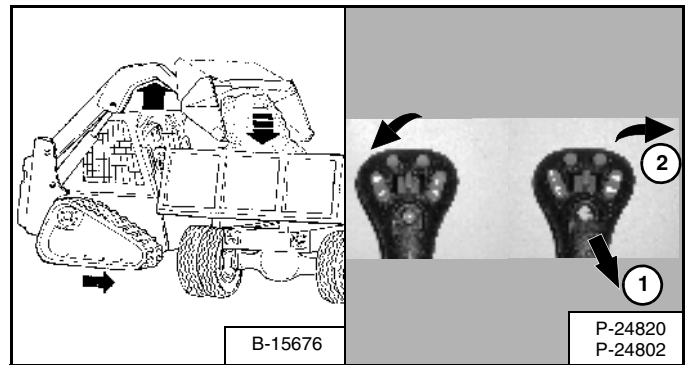

Keep the bucket low when moving to the area where you want to empty the bucket.

Raise the lift arms (Item 1) [Figure OI-96]. Level the bucket (Item 2) [Figure OI-96] while raising the lift arms to help prevent material from falling off the back of the bucket.

Drive forward slowly until the bucket is over the top of the truck box or bin.

Empty the bucket (Item 2) [Figure OI-96]. If all material is near the side of the truck or bin, use the bucket tilt to move it to the other side.

! WARNING

Never dump over an obstruction, such as a post, that can enter the operator cab. The machine could tip forward and cause injury or death.

W-2057-0694

OPERATING PROCEDURE (CONT'D)

Selectable Joystick Control (SJC) with 'ISO' Pattern Selected (Cont'd)

Leveling The Ground (Using Float Position):

Figure OI-97

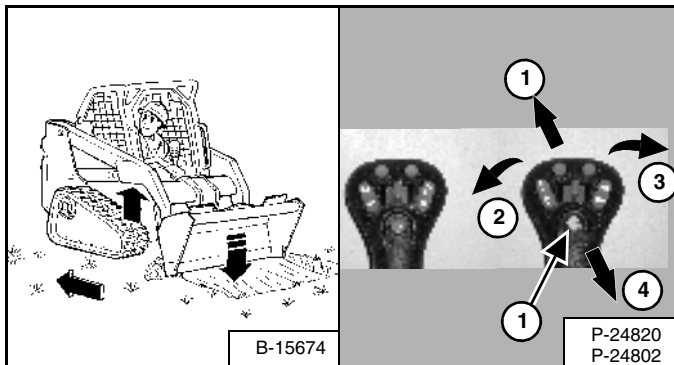

Press and hold the float button (Item 1) [Figure OI-97] while the joystick is in neutral. While lowering the lift arms (Item 2) [Figure OI-97], release the float button.

Tilt the bucket forward (Item 3) [Figure OI-97] to change the position of the cutting edge of the bucket.

With the bucket tilted farther forward, there is more force on the cutting edge and more loose material can be moved.

Drive backward to level loose material.

To disengage, press the float button again or raise the lift arms (Item 4) [Figure OI-97].

IMPORTANT

Never drive forward when the hydraulic control for lift arms is in float position.

I-2005-1285

Digging A Hole

Figure OI-98

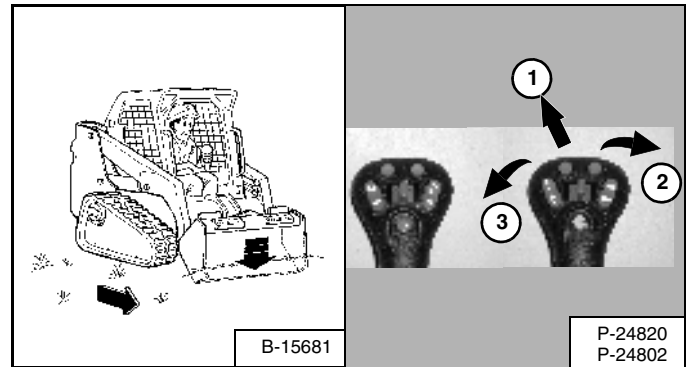

Lower the lift arms all the way (Item 1) [Figure OI-98]. Put the cutting edge of the bucket on the ground (Item 2) [Figure OI-98].

Drive forward slowly and continue to tilt the bucket down (Item 2) [Figure OI-98] until it enters the ground.

Raise the cutting edge a small amount (Item 3) [Figure OI-98] to increase traction and keep an even digging depth. Continue to drive forward until the bucket is full. When the ground is hard, raise and lower the cutting edge (Items 2 & 3) [Figure OI-98] while driving forward.

Tilt the bucket backward (Item 3) [Figure OI-98] as far as it will go when the bucket is full.

Filling The Hole

Figure OI-99

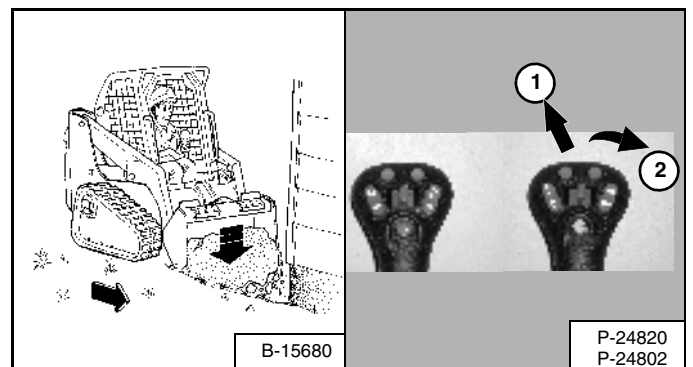

Lower the lift arms (Item 1) [Figure OI-99] and put the cutting edge of the bucket on the ground (Item 2) [Figure OI-99]. Drive forward to the edge of the hole to push the material into the hole.

Tilt the bucket forward (Item 2) [Figure OI-99] as soon as it is past the edge of the hole.

If necessary, raise the lift arms to empty the bucket.

PARKING THE BOBCAT LOADER

Parking Procedure

Stop the Bobcat loader on level ground.

Figure OI-100

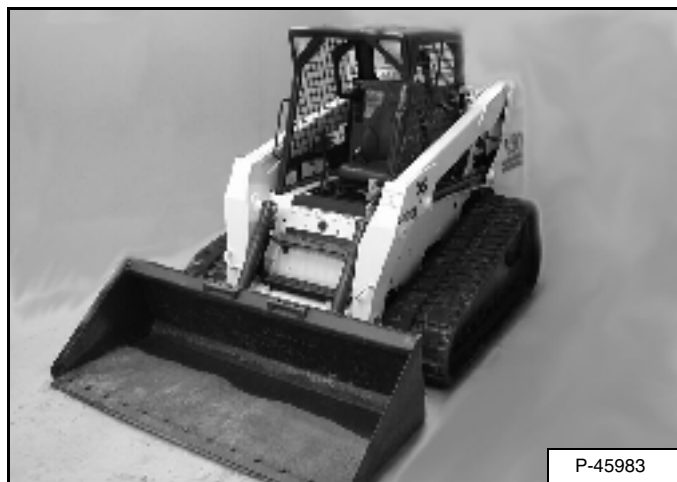

Lower the lift arms fully and put the attachment flat on the ground [Figure OI-100].

Pull the engine speed control lever fully backward to decrease the engine speed.

Let the engine run at idle speed for several minutes to let the turbocharger cool before stopping the engine.

Turn the key switch to the STOP position (*Standard Panel*) or press the STOP Button (*Deluxe Panel*).

WARNING

Before you leave the operator's seat:

- Lower the lift arms, put the attachment flat on the ground.
- Stop the engine.
- Engage the parking brake.
- Raise seat bar
- (*Foot Pedal Controls Only*) Move pedals until both lock.

(Advanced Control System (ACS)) Move the hydraulic controls to the NEUTRAL POSITION to make sure that both lift and tilt functions are deactivated. The seat bar system must deactivate the lift and tilt control functions when the seat bar is up. Service the system if hand controls do not deactivate.

- (*Selectable Joystick Control - SJC*) Move the joysticks to the NEUTRAL POSITION to make sure that travel and hydraulic functions are deactivated.

The seat bar system must deactivate these functions when the seat bar is up. Service the system if controls do not deactivate.

W-2463-0603

Engage the parking brake.

Lift the seat bar and make sure the lift and tilt functions are deactivated.

Unbuckle the seat belt.

Remove the key from the switch (*Standard Panel*) to prevent operation of the loader by unauthorized personnel.

TRANSPORTING THE BOBCAT LOADER

Loading Onto Transport Vehicle

WARNING

Adequately designed ramps of sufficient strength are needed to support the weight of the machine when loading onto a transport vehicle. Wood ramps can break and cause personal injury.

W-2058-0494

Be sure the transport and towing vehicles are of adequate size and capacity (See Fluid Capacities on Page SPEC-6), for weight of loader.

Figure OI-101



A loader with an empty bucket or no attachment must be loaded backward onto the transport vehicle [Figure OI-101].

The rear of the trailer must be blocked or supported (Item 1) [Figure OI-101] when loading or unloading the loader to prevent the front end of the trailer from raising up.

Fastening To Transport Vehicle

Figure OI-102

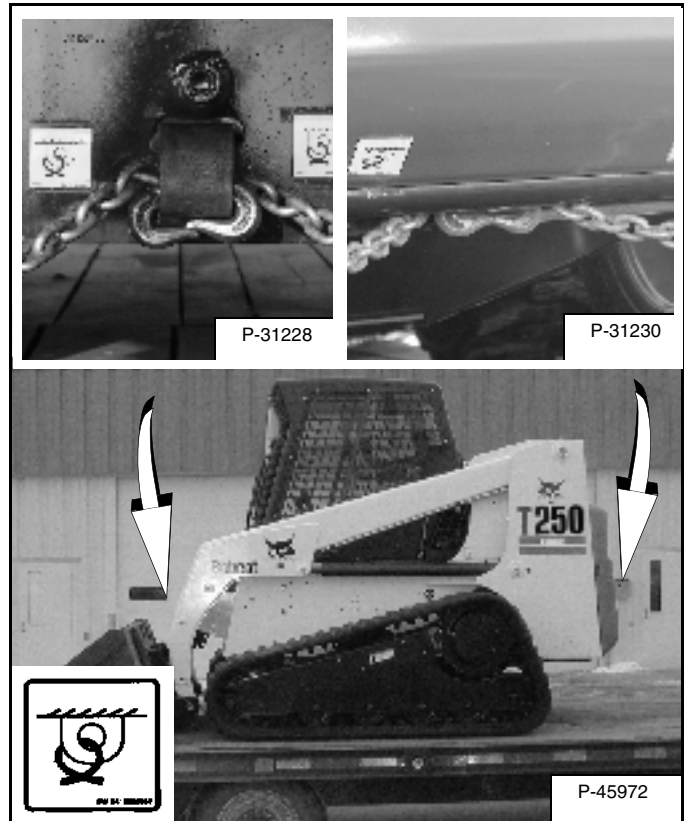

Use the following procedure to fasten the Bobcat loader to the transport vehicle to prevent the loader from moving during sudden stops or when going up or down slopes [Figure OI-102].

- Lower the bucket or attachment to the floor.
- Stop the engine.
- Engage the parking brake.
- Install chains at the front and rear loader tie down positions [Figure OI-102].
- Fasten each end of the chain to the transport vehicle.

TOWING THE LOADER

Towing Procedure

The track loader has a Spring Applied Pressure Release (SAPR) brake system. Because of this type of brake, along with the weight and design of the track loader, there is not a recommended towing procedure.

To prevent damage to the loaders hydrostatic system, the loader must be moved only a short distance at slow speed. (Example: Moving the loader onto a transport vehicle.)

The towing chain (or cable) must be rated at 1 & 1/2 times the weight of the loader (See loader specifications (T250) on Page SPEC-3).

Move the Bobcat loader at 2 MPH (3,2 km/hr) or less for not more than 25 feet (7,6 meters).

LIFTING THE LOADER

Single Point Lift

! WARNING

AVOID INJURY OR DEATH

- Before lifting, check fasteners on single point lift and operator cab.
- Assemble front cab fasteners as shown in this manual.
- Never allow riders in the cab or bystanders within 5 meters while lifting the machine.

W-2007-0497

The loader can be lifted with the Single Point Lift which is available as a kit from your Bobcat loader dealer.

Figure OI-103

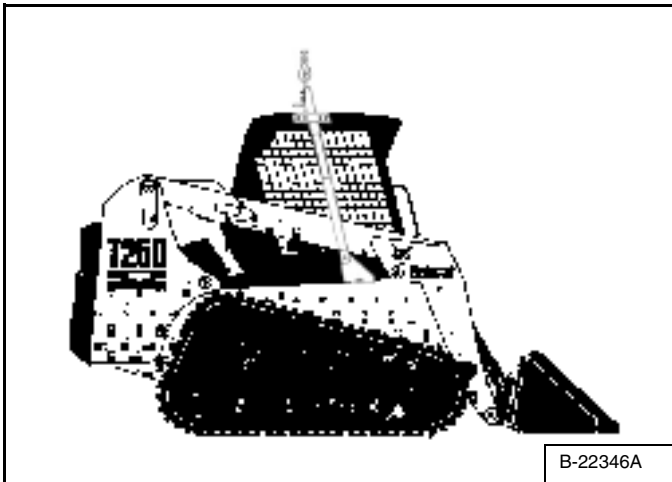

Install the kit as explained in the Instructions with the kit and attach lift as shown [Figure OI-103].

The Single Point Lift, supplied by Bobcat, is designed to lift and support the Bobcat loader without affecting roll over and falling object protection features of the operator cab.

Four Point Lift

! WARNING

AVOID INJURY OR DEATH

- Before lifting, check fasteners on four point lift.
- Never allow riders in the cab or bystanders within 5 meters while lift the machine.

W-2160-0694

The loader can be lifted with the Four Point Lift which is available as a kit from your Bobcat loader dealer. The backhoe mounting kit must also be installed to provide lift points at the front of the loader.

Figure OI-104

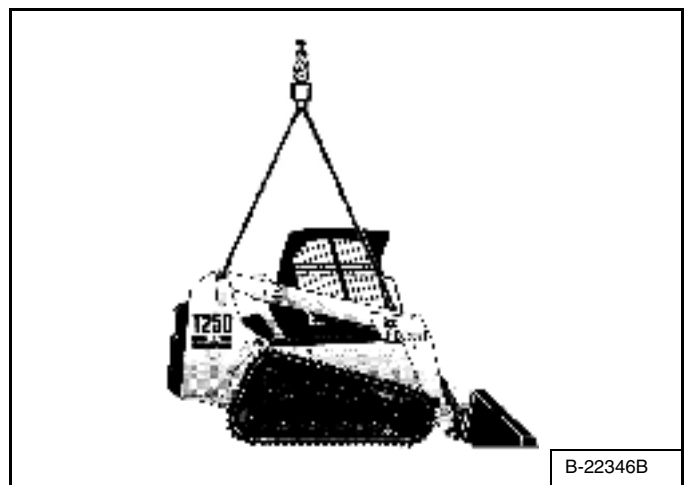

Attach cables or chains to lift eyes [Figure OI-104].



Bobcat®

PREVENTIVE MAINTENANCE

AIR CLEANER SERVICE	PM-18
Replacing Filter Elements	PM-18
ALTERNATOR BELT	PM-31
Adjusting the Air Conditioner Belt	PM-31
Adjusting The Alternator Belt	PM-31
BOB-TACH (HAND LEVER)	PM-34
Inspection And Maintenance	PM-34
BOB-TACH (POWER) (OPTION)	PM-35
Inspection And Maintenance	PM-35
BOBCAT INTERLOCK CONTROL SYSTEM (BICS)	PM-13
Inspecting Deactivation Of Lift And Tilt Functions (ACS and SJC)	PM-13
Inspecting Deactivation Of The Auxiliary Hydraulics System (Engine STOPPED - Key ON)	PM-13
Inspecting The BICS Controller (Engine Stopped - Key ON)	PM-13
Inspecting The Lift Arm By-Pass Control	PM-13
Inspecting The Seat Bar Sensor (Engine RUNNING)	PM-13
Inspecting The Traction Lock (Engine RUNNING)	PM-13
DRIVE BELT	PM-30
Adjusting The Drive Belt	PM-30
Replacing The Drive Belt	PM-30
ELECTRICAL SYSTEM	PM-23
Cleaning Battery And Terminals	PM-23
Description	PM-23
Fuse Location	PM-23
Removing And Installing The Battery	PM-26
Using A Booster Battery (Jump Starting)	PM-24
ENGINE COOLING SYSTEM	PM-22
Cleaning The Cooling System	PM-22
ENGINE LUBRICATION SYSTEM	PM-21
Checking Engine Oil	PM-21
Replacing The Oil And Filter	PM-21
FAN GEARBOX	PM-30
Checking And Maintaining	PM-30
FUEL SYSTEM	PM-19
Filling The Fuel Tank	PM-19
Fuel Filter	PM-20
Fuel Specifications	PM-19
Removing Air From The Fuel System	PM-20

**PREVENTIVE
MAINTENANCE**

PREVENTIVE MAINTENANCE (CONT'D)

HEATING SYSTEM.....	PM-17
Cleaning And Maintenance	PM-17
HYDRAULIC / HYDROSTATIC SYSTEM.....	PM-27
Breather Cap	PM-29
Checking And Adding Fluid	PM-27
Replacing Hydraulic Fluid and Case Drain Filters	PM-28
Replacing Hydraulic/Hydrostatic Filter.....	PM-27
HYDROSTATIC MOTOR CARRIER OIL	PM-30
Removing And Replacing Oil.....	PM-30
LIFT ARM SUPPORT DEVICE	PM-6
Disengaging The Lift Arm Support Device	PM-7
Engaging The Lift Arm Support Device	PM-6
LUBRICATING THE BOBCAT LOADER.....	PM-32
Lubrication Locations.....	PM-32
OPERATOR CAB	PM-8
Cab Door Sensor (If Equipped)	PM-9
Description.....	PM-8
Emergency Exit	PM-10
Lowering The Operator Cab	PM-9
Raising The Operator Cab.....	PM-8
PIVOT PINS	PM-33
Inspection And Maintenance	PM-33
REAR DOOR	PM-16
Adjusting The Rear Door	PM-16
Opening And Closing The Rear Door.....	PM-16
REAR GRILL.....	PM-17
SEAT BAR RESTRAINT SYSTEM	PM-12
Inspecting The Seat Bar	PM-12
Maintaining The Seat Bar	PM-12
SEAT BELT	PM-11
Inspection and Maintenance.....	PM-11
SERVICE SCHEDULE.....	PM-5
Chart.....	PM-5
TRACK ROLLER AND IDLER LUBRICATION.....	PM-30
TRACK TENSION	PM-14
Adjusting Track Tension.....	PM-14

MAINTENANCE SAFETY

! WARNING

Instructions are necessary before operating or servicing machine. Read and understand the Operation & Maintenance Manual, Handbook and signs (decals) on machine. Follow warnings and instructions in the manuals when making repairs, adjustments or servicing. Check for correct function after adjustments, repairs or service. Untrained operators and failure to follow instructions can cause injury or death.

W-2003-0903

! Safety Alert Symbol: This symbol with a warning statement, means: "Warning, be alert! Your safety is involved!" Carefully read the message that follows.

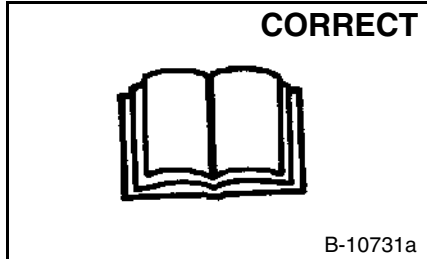

! Never service the Bobcat® Skid Steer Loader without instructions.

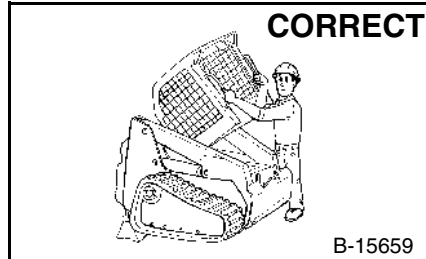

! Use the correct procedure to lift or lower operator cab.

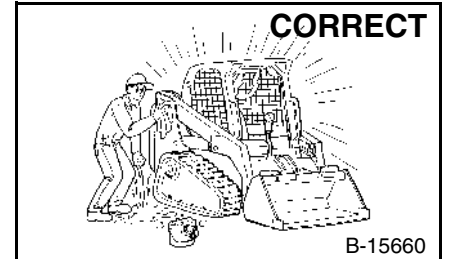

! Cleaning and maintenance are required daily.

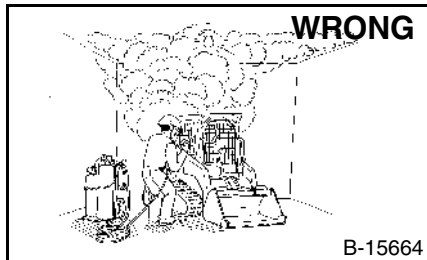

- ! Have good ventilation when welding or grinding painted parts.**
- ! Wear dust mask when grinding painted parts. Toxic dust and gas can be produced.**
- ! Avoid exhaust fume leaks which can kill without warning. Exhaust system must be tightly sealed.**

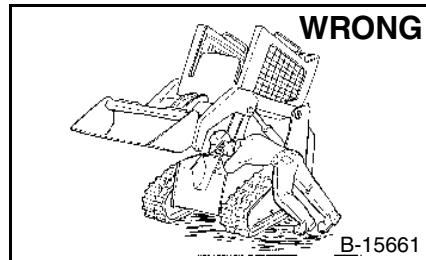

! Disconnecting or loosening any hydraulic tubeline, hose, fitting, component or a part failure can cause lift arms to drop. Do not go under lift arms when raised unless supported by an approved lift arm support device. Replace it if damaged.

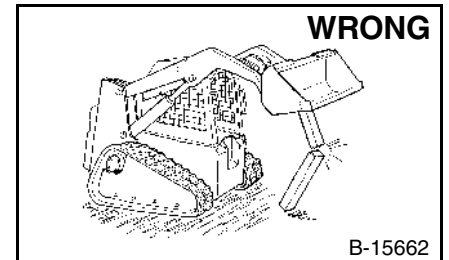

- ! Never work on loader with lift arms up unless lift arms are held by an approved lift arm support device. Replace if damaged.**
- ! Never modify equipment or add attachments not approved by Bobcat Company.**

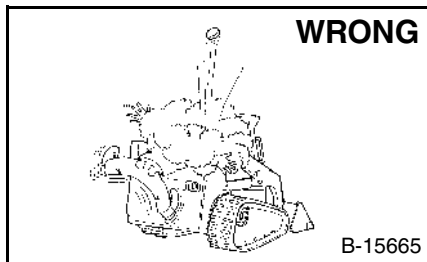

- ! Stop, cool and clean engine of flammable materials before checking fluids.**
- ! Never service or adjust loader with the engine running unless instructed to do so in the manual.**
- ! Avoid contact with leaking hydraulic fluid or diesel fuel under pressure. It can penetrate the skin or eyes.**
- ! Never fill fuel tank with engine running, while smoking or when near open flame.**

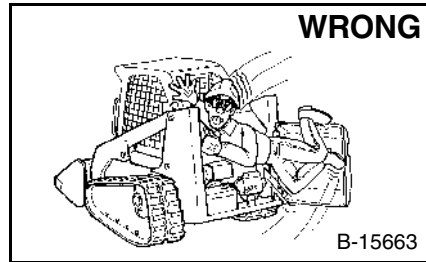

- ! Keep body, jewelry and clothing away from moving parts, electrical contact, hot parts and exhaust.**
- ! Wear eye protection to guard from battery acid, compressed springs, fluids under pressure and flying debris when engines are running or tools are used. Use eye protection approved for type of welding.**
- ! Keep rear door closed except for service. Close and latch door before operating the loader.**

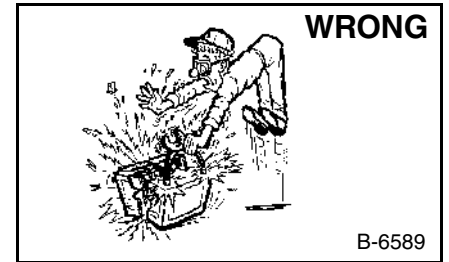

- ! Lead-acid batteries produce flammable and explosive gases.**
- ! Keep arcs, sparks, flames and lighted tobacco away from batteries.**
- ! Batteries contain acid which burns eyes or skin on contact. Wear protective clothing. If acid contacts body, flush well with water. For eye contact flush well and get immediate medical attention.**

MSW09-0903

Maintenance procedures which are given in the Operation & Maintenance Manual can be performed by the owner/operator without any specific technical training. Maintenance procedures which are **not** in the Operation & Maintenance Manual must be performed **ONLY BY QUALIFIED BOBCAT SERVICE PERSONNEL**. Always use genuine Bobcat replacement parts. The Service Safety Training Course is available from your Bobcat dealer.



Bobcat®

SERVICE SCHEDULE

Chart

Maintenance work must be done at regular intervals. Failure to do so will result in excessive wear and early failures. The service schedule is a guide for correct maintenance of the Bobcat loader.

 WARNING	<p>Instructions are necessary before operating or servicing machine. Read and understand the Operation & Maintenance Manual, Handbook and signs (decals) on machine. Follow warnings and instructions in the manuals when making repairs, adjustments or servicing. Check for correct function after adjustments, repairs or service. Untrained operators and failure to follow instructions can cause injury or death.</p>
W-2003-0903	

SERVICE SCHEDULE		HOURS					
ITEM	SERVICE REQUIRED	8-10	50	100	■ 250	■ 500	■ 1000
Engine Oil	Check the oil level and add as needed. Do not overfill.						
Engine Air Filter and Air System	Check display panel. Service only when required. Check for leaks and damaged components.						
Engine Cooling System	Clean debris from oil cooler, radiator & grill. Check coolant level COLD and add premixed coolant as needed.						
Fuel Filter	Remove the trapped water.						
Lift Arms, Cylinders, Bob-Tach Pivot Pins and Wedges	Lubricate with multi-purpose lithium based grease.						
Seat Bar, Control Interlocks, Seat Belt, Seat Belt Retractors	Check the condition of seat belt. Clean or replace seat belt retractors as needed. Check the seat bar and control interlocks for correct operation. Clean dirt and debris from moving parts.						
Bobcat Interlock Control System (BICS™)	Check that four BICS™ indicator lights and functions are activated. See details in this Manual.						
Safety Signs and Safety Treads	Check for damaged signs (decals) and safety treads. Replace any signs or safety treads that are damaged or worn.						
Operator Cab	Check the fastening bolts, washers and nuts. Check the condition of the cab.						
Indicators and Lights	Check for correct operation of all indicators and lights.						
Heater and A/C Filters (If Equipped)	Clean or replace filters as needed.						
Hydraulic Fluid, Hoses and Tubelines	Check fluid level and add as needed. Check for damage and leaks. Repair or replace as needed.						
Tracks	Check for damaged or worn tracks and correct tension.	☐					
Track Sprocket Bolts	Check torque. Tighten as needed. See procedure in this manual.		*				
Foot Pedals or Hand Controls or Joysticks, and Steering Levers	Check for correct operation. Repair or adjust as needed.						
Parking Brake	Check operation.						
Spark Arrestor Muffler	Clean the spark chamber.						
Battery	Check cables, connections and electrolyte level. Add distilled water as needed.						
Steering Lever Pivots	Grease fittings.						
Fuel Filter	Replace filter element.						
Engine/Hydro. Drive Belt	Check for wear or damage. Check idler arm stop.		○				
Fan Drive Gearbox	Check gear lube level. Add as needed.						
Alternator Belt & A / C Belt (If Equipped)	Check condition and tension. Adjust or replace as needed.						
Bobcat Interlock Control System (BICS™)	Check the function of the lift arm by-pass control.						
Engine Oil and Filter	Replace oil and filter. Use CD or better grade oil and Bobcat filter.		*				
Hydraulic/Hydrostatic Filter, Reservoir Breather Cap	Replace the hydrostatic filter, steering valve filter and the reservoir breather cap.		▼				
Hydrostatic Motor Carrier	Replace oil with high performance synthetic oil P/N 6682546.						
Hydraulic Reservoir	Replace the fluid.						
Case Drain Filters	Replace the filters.						
Coolant	Replace the coolant	Every 2 years					
Engine Valves	Adjust the engine valves.					+	

- Or every 12 months.
- ☐ Check every 8-10 hours for the first 24 hours. Then at 50 hour intervals.
- * Check after the first 50 hours of operation only.
- Inspect the new belt after first 50 hours.
- * First oil and filter change must occur at 50 hours; 500 hours thereafter.
- ▼ Replace filter element after the first 50 hours and when the transmission warning light comes ON.
- + First valve adjustment must occur at 500 hours; 1000 hours thereafter.

LIFT ARM SUPPORT DEVICE

Maintenance and service work can be done with the lift arms lowered. If the lift arms are raised, use the following procedures to engage and disengage an approved lift arm support device.

Engaging The Lift Arm Support Device

⚠ WARNING

Never work on a machine with the lift arms up unless the lift arms are secured by an approved lift arm support device. Failure to use an approved lift arm support device can allow the lift arms or attachment to fall and cause injury or death.

W-2059-0598

⚠ WARNING

Service lift arm support device if damaged or if parts are missing. Using a damaged lift arm support or with missing parts can cause lift arms to drop causing injury or death.

W-2271-1197

Figure PM-1

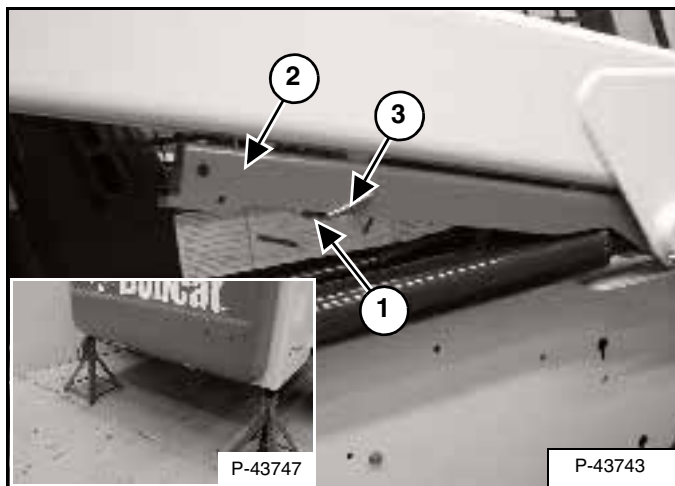

Put jackstands under the rear corners of the loader frame (Inset) [Figure PM-1].

Disconnect the spring from the lift arm support device retaining pin (Item 1) [Figure PM-1]. Support the lift arm support device (Item 2) [Figure PM-1] with your hand and remove the retaining pin (Item 3) [Figure PM-1].

Figure PM-2

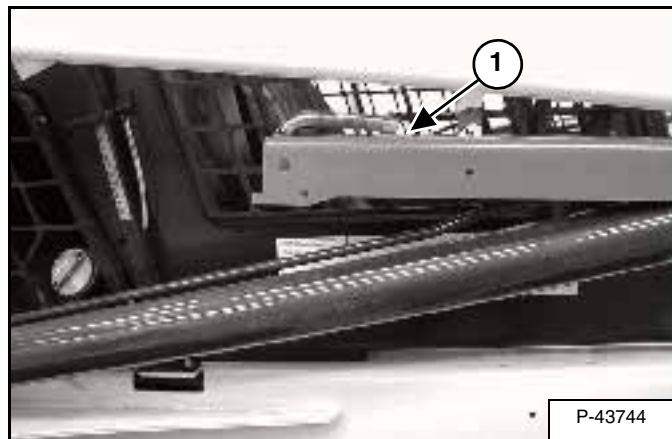

Lower the lift arm support device to the top of the lift cylinder. Hook the free end of the spring (Item 1) [Figure PM-2] to the lift arm support device so there will be no interference with the support device engagement.

Sit in the operator's seat, fasten the seat belt and lower the seat bar. Start the engine.

Figure PM-3

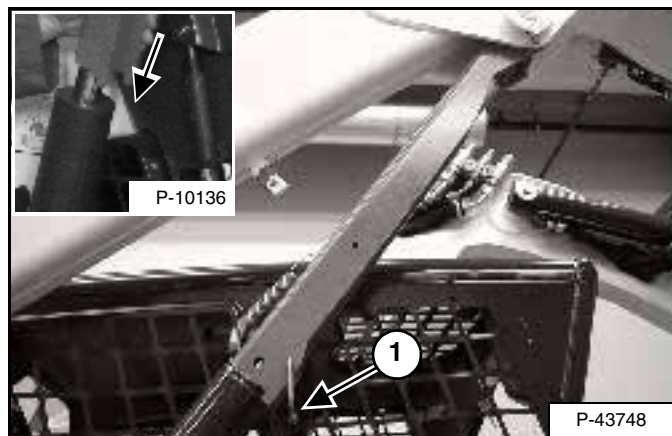

Raise the lift arms until the lift arm support device drops onto the lift cylinder rod (Inset) [Figure PM-3]

Lower the lift arms slowly until the support device is held between the lift arm and the lift cylinder. Stop the engine. Raise the seat bar and move both pedals until both pedals lock.

Install pin (Item 1) [Figure PM-3] into the rear of the lift arm support device below the cylinder rod.

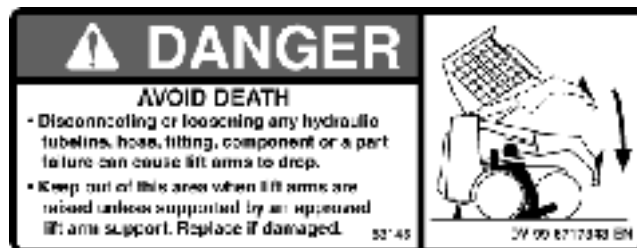

LIFT ARM SUPPORT DEVICE (CONT'D)

Disengaging The Lift Arm Support Device

Remove the pin from the lift arm support device.

Figure PM-4

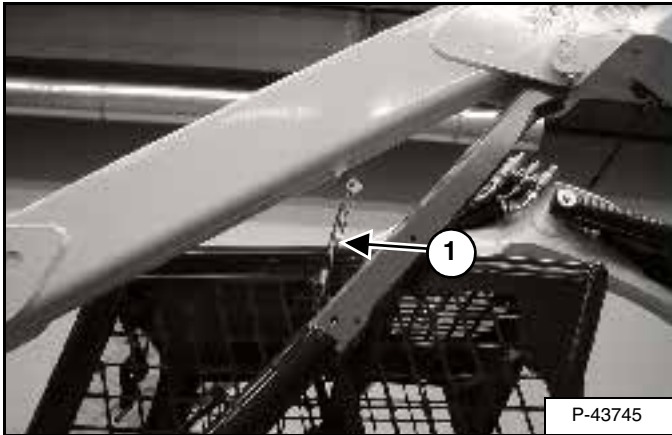

Connect the spring (Item 1) [Figure PM-4] from the lift arm support device to the bracket below the lift arms.

Sit in the operator's seat fasten the seat belt and lower the seat bar. Start the engine.

Figure PM-5



Raise the lift arms a small amount. The spring will lift the support device off the lift cylinder rod [Figure PM-5]. Lower the lift arms. Stop the engine.

Raise the seat bar, disconnect the seat belt, move pedals until both pedals lock and exit the cab.

Disconnect the spring from the bracket.

Raise the support device into storage position and insert pin through lift arm support device and bracket. (See LIFT ARM SUPPORT DEVICE on Page PM-6.)

Remove the jackstands.

OPERATOR CAB

Description

The Bobcat loader has an operator cab (ROPS and FOPS) as standard equipment to protect the operator from rollover and falling objects. Check with your dealer if the operator cab has been damaged. The seat belt must be worn for roll over protection.

ROPS / FOPS - Roll Over Protective Structure per SAE J1040 and ISO 3471, and Falling Object Protective Structure per SAE J1043 and ISO 3449, Level I. Level II is available.

Level I - Protection from falling bricks, small concrete blocks, and hand tools encountered in operations such as highway maintenance, landscaping, and other construction sites.

Level II - Protection from falling trees, rocks: for machines involved in site clearing, overhead demolition or forestry.

Raising The Operator Cab

Always stop the engine before raising or lowering the cab.

Stop the loader on a level surface. Lower the lift arms. If the lift arms must be up while raising the operator cab, install the lift arm support device. (See LIFT ARM SUPPORT DEVICE.)

Figure PM-6



Install jackstands under the rear of the loader frame [Figure PM-6].

Figure PM-7

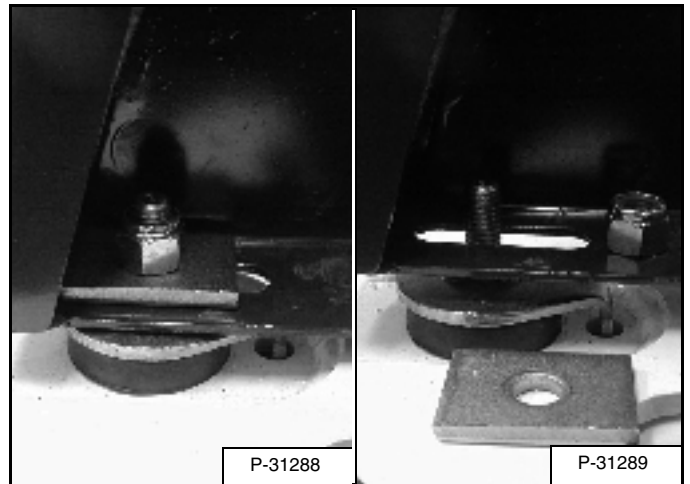

Remove the nuts and plates [Figure PM-7] (both sides) at the front corners of the cab.

Figure PM-8



Lift on the grab handles and bottom of the operator cab [Figure PM-8] slowly until the cab is all the way up and the latching mechanism engages.

Advanced Control System (ACS)



OPERATOR CAB (CONT'D)

Lowering The Operator Cab

Always stop the engine before raising or lowering the cab.

NOTE: Make sure the seat bar is fully raised or lowered when lowering the cab. Always use the grab handles to lower the cab.

Figure PM-9

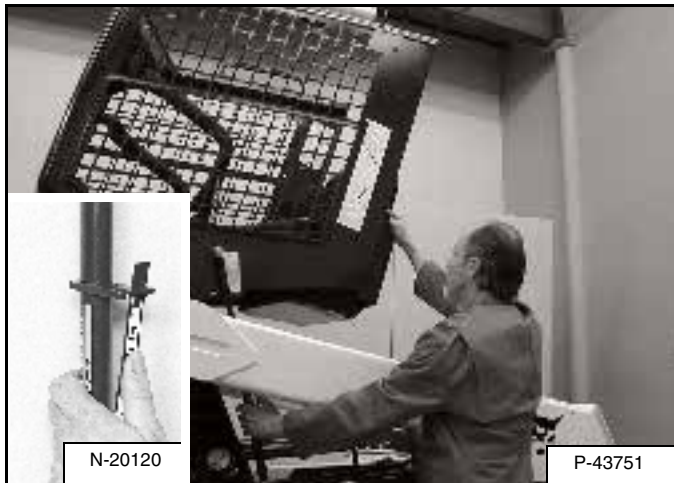

Pull down on the bottom of the operator cab until it stops at the latching mechanism [Figure PM-9].

NOTE: The weight of the cab increases when equipped with options and accessories such as cab door, heater, air conditioning, etc. In these cases, the cab may need to be raised slightly from the latch to be able to release the latch.

Support the cab and release the latching mechanism (Inset) [Figure PM-9]. Remove your hand from latching mechanism when the cab is past the latch stop. Use both hands to lower the cab all the way.

WARNING

PINCH POINT CAN CAUSE INJURY
Remove your hand from the latching mechanism when the cab is past the latch stop.

W-2458-0803

Figure PM-10

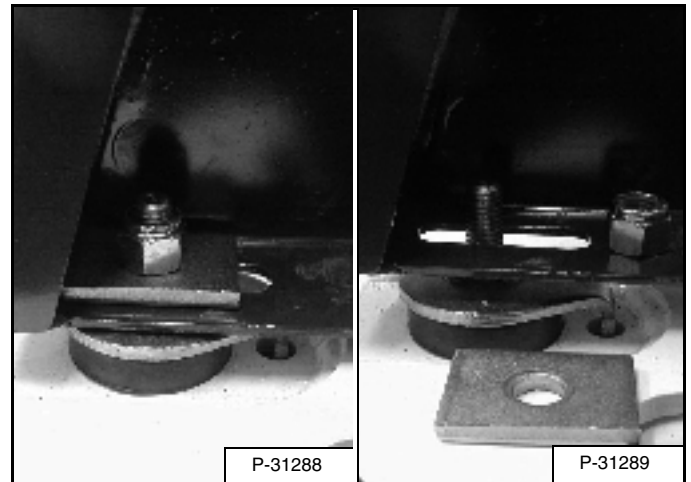

Install the plates and nuts (both sides) [Figure PM-10].

Tighten the nuts to 54-68 Nm torque.

Cab Door Sensor (If Equipped)

Figure PM-11

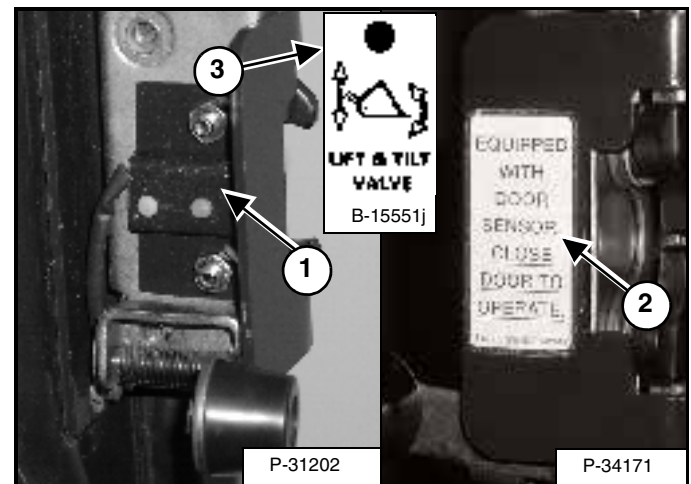

The cab door (option) has a sensor (Item 1) [Figure PM-11] installed which deactivates the lift and tilt valves when the door is open.

A decal is located on the latch mechanism (Item 2) [Figure PM-11].

The LIFT & TILT VALVE light (Item 3) [Figure PM-11] will be ON when the door is closed and the PRESS TO OPERATE LOADER Button is pressed.

OPERATOR CAB (CONT'D)

Emergency Exit

The front opening on the operator cab and rear window provide exits.

Rear Window (If Equipped)

Figure PM-12

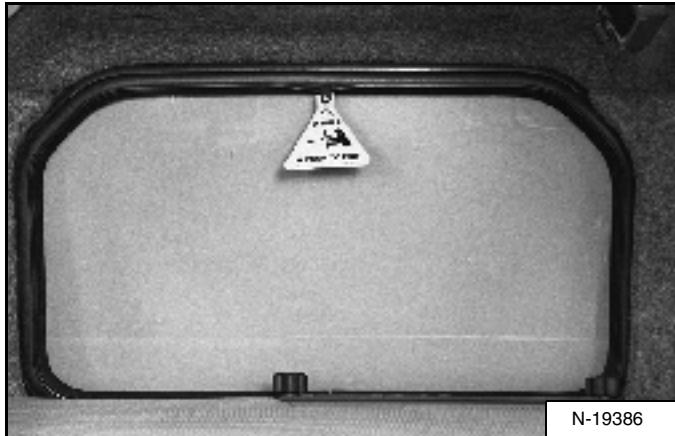

Pull on the tag [Figure PM-12] on the top of the rear window to remove the rubber cord.

Push the rear window out of the rear of the operator cab.

Figure PM-13



Exit through the rear of the operator cab [Figure PM-13].

WARNING

Never modify operator cab by welding, grinding, drilling holes or adding attachments unless instructed to do so by Bobcat. Changes to the cab can cause loss of operator protection from rollover and falling objects, and result in injury or death.

W-2069-1299

Front Door (If Equipped)

Figure PM-14

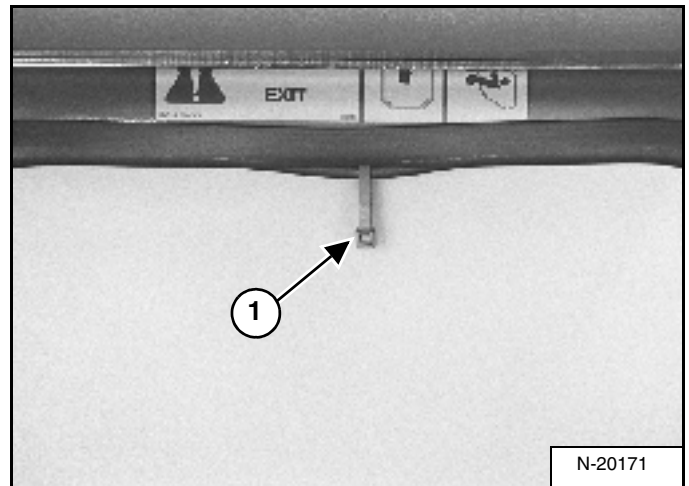

NOTE: When an Operator Cab Enclosure Kit is installed, the window of the front door can be used as an emergency exit [Figure PM-15].

Pull the plastic loop at the top of the window in the front door to remove the rubber cord (Item 1) [Figure PM-14].

Figure PM-15

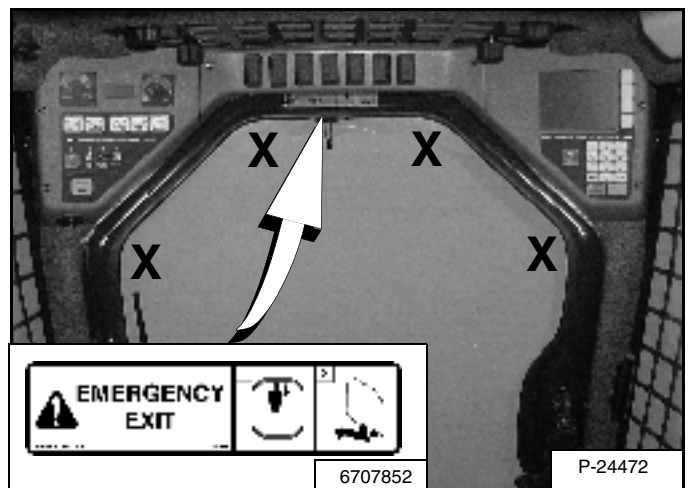

Push the window out with your foot [Figure PM-15] at any corner (X) of the window.

Exit through the front door.

SEAT BELT

Inspection and Maintenance

WARNING

Failure to properly inspect and maintain seat belt can cause serious injury or death in the event of an accident.

The entire seat belt system must be replaced if the machine has been involved in an accident or if any part has been damaged.

W-2466-0703

Check the seat belt daily for correct function.

Inspect the seat belt system thoroughly at least once each year or more often if the machine is exposed to severe environmental conditions or applications.

Any seat belt system that shows cuts, fraying, extreme or unusual wear, significant discolorations due to ultraviolet (UV) exposure, dusty/dirty conditions, abrasion to the seat belt webbing, or damage to the buckle, latch plate, retractor (if equipped), hardware or any other obvious problem should be replaced immediately.

1. Check the webbing. If the system is equipped with a retractor, pull the webbing completely out and inspect the full length of the webbing. Look for cuts, wear, fraying, dirt and stiffness.
2. Check the buckle and latch for correct operation. Make sure latch plate is not excessively worn, deformed or buckle is not damaged or casing broken.
3. Check the retractor web storage device (if equipped) by extending webbing to determine if it looks correct and that it spools out and retracts webbing correctly.
4. Check webbing in areas exposed to ultraviolet (UV) rays from the sun or extreme dust or dirt. If the original color of the webbing in these areas is extremely faded and / or the webbing is packed with dirt, the webbing strength may have deteriorated.

See your Bobcat dealer for seat belt system replacement parts for your machine.

Figure PM-16

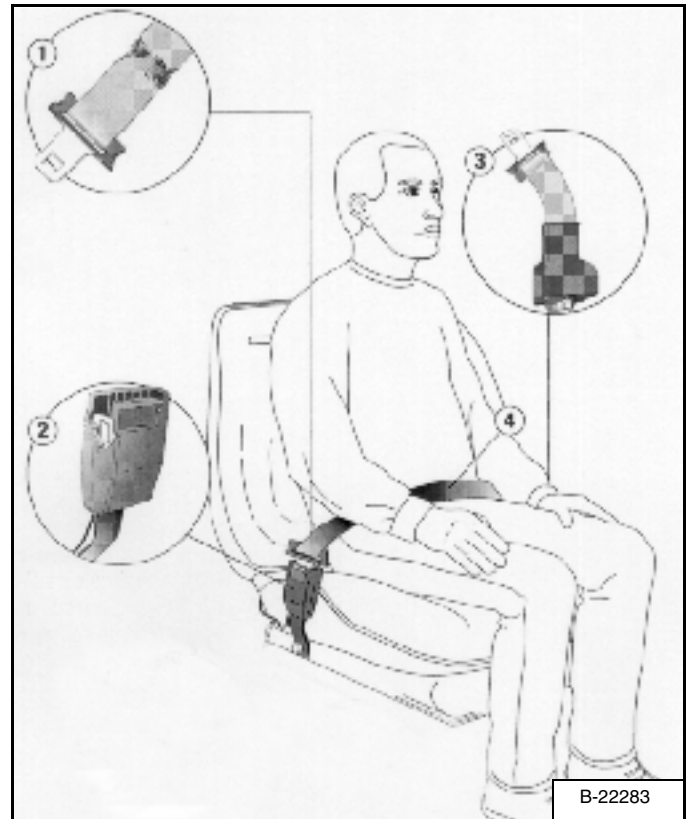

SEAT BAR RESTRAINT SYSTEM

The seat bar restraint system has a pivoting seat bar with arm rests.

The operator controls the use of the seat bar. The seat bar in the down position helps to keep the operator in the seat.

Models with foot pedals have hydraulic valve spool interlocks for the lift and tilt functions. The spool interlocks require the operator to lower the seat bar in order to operate the foot pedal controls.

When the seat bar is down, the PRESS TO OPERATE LOADER Button is activated and the engine is running, the lift, tilt and traction drive functions can be operated.

When the seat bar is up, the lift and tilt control pedals are locked when returned to the NEUTRAL position.

Models with the Advanced Control System (ACS) have mechanical interlocks for the handles and pedals. The interlocks for the handles and pedals require the operator to lower the seat bar in order to operate the controls.

When the seat bar is down, the PRESS TO OPERATE LOADER button is activated and the engine is running, the lift, tilt and traction drive functions can be operated using the selected controls (handles, or foot pedals).

When the seat bar is up, the handles and pedals are locked when returned to the NEUTRAL position.

Models with Selectable Joystick Control (SJC) have electrical deactivation of joystick functions. Activation of functions require the operator to lower the seat bar.

When the seat bar is down, the PRESS TO OPERATE LOADER button is activated and the engine is running, the lift, tilt and traction drive functions can be operated.

When the seat bar is up, the joystick functions are deactivated even though the joystick does not mechanically lock.

Inspecting The Seat Bar

Sit in the seat and fasten the seat belt. Engage the parking brake. Pull the seat bar all the way down. Start the engine. Press the PRESS TO OPERATE LOADER Button.

Operate the hydraulic controls to check that both the lift and tilt functions operate correctly. Raise the lift arms until the attachment is about 600 mm off the ground.

Raise the seat bar. Move the hydraulic controls. Pedals and handles (if equipped) must be firmly locked in the NEUTRAL position (except joysticks). There must be no motion of the lift arms or tilt (attachment) when the controls are moved.

Lower the seat bar, press the PRESS TO OPERATE LOADER Button, lower the lift arms. Operate the lift control. While the lift arms are going up, raise the seat bar. The lift arms must stop.

Lower the seat bar, press the PRESS TO OPERATE LOADER Button, lower the lift arms and put the attachment flat on the ground. Stop the engine. Raise the seat bar. Operate the foot pedals and handles (if equipped) to be sure they are firmly locked in the NEUTRAL position (except joysticks).

Maintaining The Seat Bar

(See SERVICE SCHEDULE on Page PM-5) and on the loader for correct service interval.

Figure PM-17

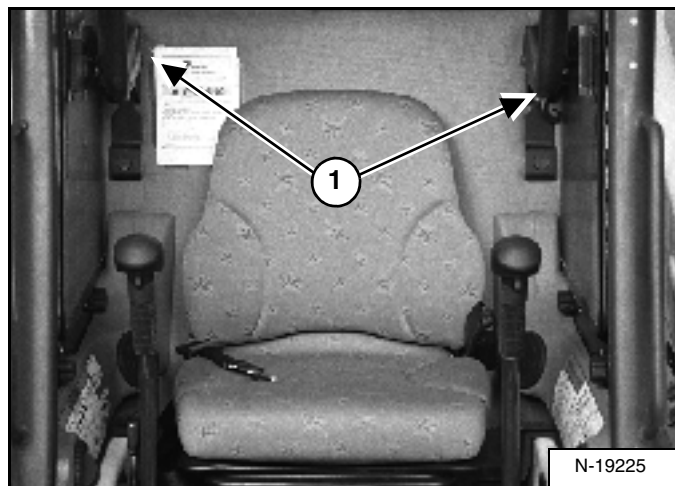

Use compressed air to clean any debris or dirt from the pivot parts (Item 1) [Figure PM-17]. Do not lubricate. Inspect all mounting hardware. The correct bolt torque is 35 Nm.

If the seat bar system does not function correctly, replace parts that are worn or damaged. Use only genuine Bobcat replacement parts.



The seat bar system must deactivate the lift and tilt control functions when the seat bar is up. Service the system if hydraulic controls do not deactivate.

W-2465-0703

BOBCAT INTERLOCK CONTROL SYSTEM (BICS)

Inspecting The BICS Controller (Engine Stopped - Key ON)

Figure PM-18

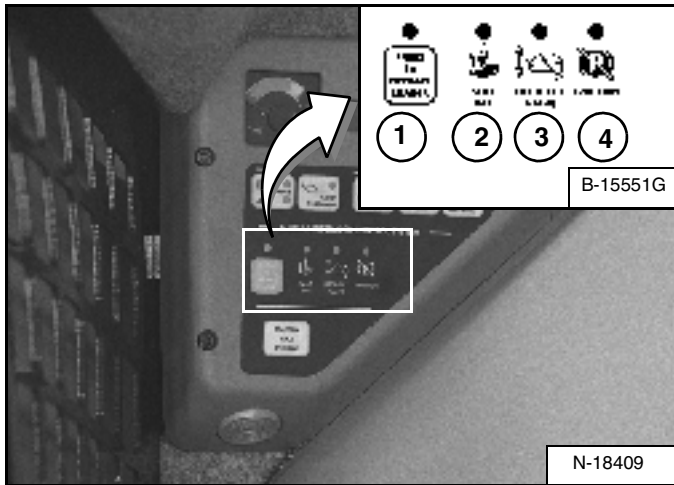

1. Sit in operator's seat. Turn key ON. (*Standard Panel*), press RUN/ENTER Button (*Deluxe Panel*), lower seat bar and disengage parking brake. Press the PRESS TO OPERATE LOADER Button. Three BICS lights (Items 1, 2 & 3) [PRESS TO OPERATE LOADER, SEAT BAR, AND LIFT & TILT VALVE] on left instrument panel should be ON [Figure PM-18].
2. Raise seat bar fully. All four BICS lights (Items 1, 2, 3, and 4) [PRESS TO OPERATE LOADER, SEAT BAR, LIFT & TILT VALVE AND TRACTION*] on left instrument panel should be OFF [Figure PM-18].

NOTE: Record what lights are blinking (if any) and the number of light flashes. (See BICS™ SYSTEM on Page SA-3.)

Inspecting Deactivation Of The Auxiliary Hydraulics System (Engine STOPPED - Key ON)

3. Sit in operator's seat, lower seat bar, and press the PRESS TO OPERATE LOADER Button. Press the auxiliary hydraulics FLOW Button. The auxiliary hydraulics FLOW Button light will come ON. Raise the seat bar. The light should be OFF.

Inspecting The Seat Bar Sensor (Engine RUNNING)

4. Sit in operator's seat, lower seat bar, engage parking brake and fasten seat belt.
5. Start engine and operate at low idle. Press the PRESS TO OPERATE LOADER Button. While raising the lift arms, raise the seat bar fully. The lift arms should stop. Repeat using the tilt function.

Inspecting The Traction Lock (Engine RUNNING)

6. Fasten seat belt, disengage parking brake, press the PRESS TO OPERATE LOADER Button and raise seat bar fully. Move steering levers slowly forward and backward. The TRACTION lock should be engaged. Lower the seat bar. Press the PRESS TO OPERATE LOADER Button.
7. Engage parking brake and move steering levers slowly forward and backward. The TRACTION lock should be engaged.

NOTE: *The TRACTION light on the left instrument panel will remain OFF until the engine is started, the PRESS TO OPERATE LOADER Button is pressed and the parking brake is disengaged.

Inspecting The Lift Arm By-Pass Control

8. Raise the lift arms 2 meters off the ground. Stop engine. Turn lift arm by-pass control knob clockwise 1/4 turn. Pull up and hold lift arm by-pass control knob until lift arms slowly lower.

Inspecting Deactivation Of Lift And Tilt Functions (ACS and SJC)

9. Sit in operator's seat and fasten seat belt. Lower seat bar, start engine and press the PRESS TO OPERATE LOADER Button.
10. Raise lift arms about 2 meters off the ground.
11. Turn key OFF (*Standard Panel*), press STOP Button (*Deluxe Panel*), and wait for the engine to come to a complete stop.
12. Turn key ON (*Standard Panel*), press RUN / ENTER Button (*Deluxe Panel*). Press the PRESS TO OPERATE LOADER Button, move hand control or joystick to lower the lift arms. Lift arms should not lower.
13. Move the control (foot pedal, hand control or joystick) to tilt the bucket (or attachment) forward. The bucket (or attachment) should not tilt forward.

! WARNING

AVOID INJURY OR DEATH

The Bobcat Interlock Control System (BICS™) must deactivate the lift, tilt and traction drive functions. If it does not, contact your dealer for service. DO NOT modify the system.

W-2151-0394

TRACK TENSION

Adjusting Track Tension

Track tension is important for good performance and to prevent the tracks from derailing.

NOTE: The wear of track rollers vary with the working conditions and different types of soil conditions.

Park the loader on a level surface.

Figure PM-19

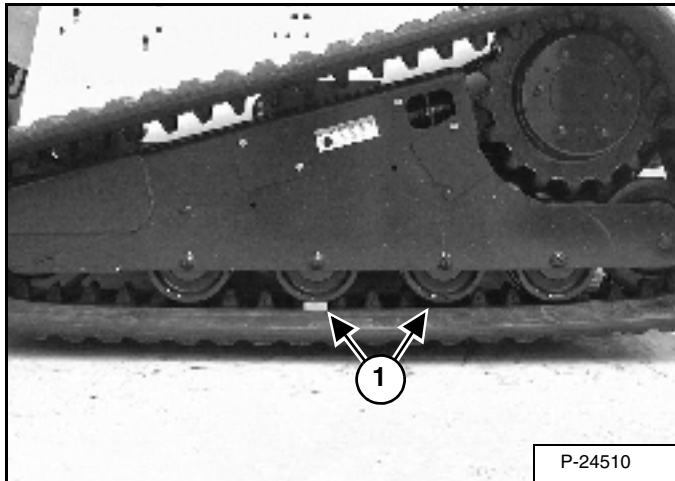

Raise one side of the loader and put jackstands at the front and rear of the loader frame so that the track is about 76 mm off the ground [Figure PM-19]. Lower the loader to the jackstands. Be sure the jackstands do not touch the tracks.

Measure the track sag at either middle track roller (Item 1) [Figure PM-19].

Figure PM-20

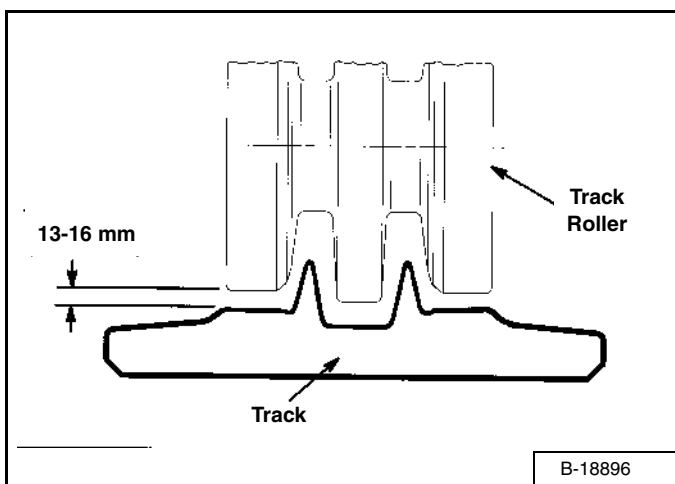

DO NOT put your fingers into the pinch points between the track and the roller. Use a 1/2 to 5/8 inch bolt, dowel or block to check the gap (Item 1) [Figure PM-19], and [Figure PM-20].

! WARNING

AVOID INJURY OR DEATH

Keep fingers and hands out of pinch points when checking the track tension.

W-2142-0189

Figure PM-21

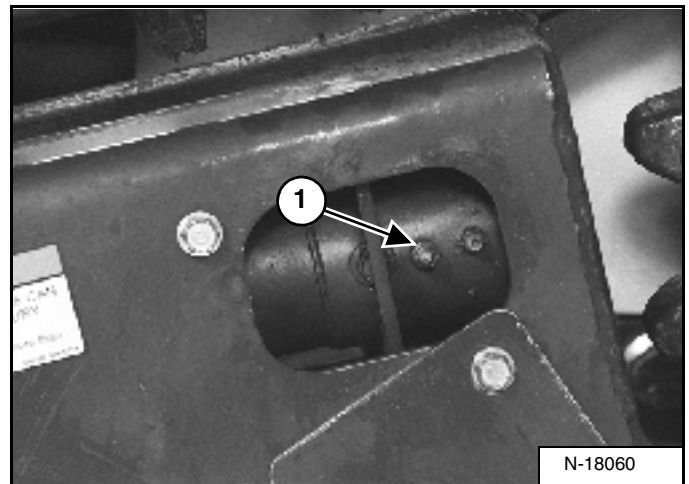

Loosen the cover bolts and turn the cover down [Figure PM-21].

! WARNING

AVOID INJURY OR DEATH

Do not loosen lubricator more than 1 - 1/2 turns.

Do not loosen parts other than the lubricator. Grease is under high pressure.

VM-00-8334739-EN

Increase Track Tension:

Add grease to the adjustment fitting (Item 1) [Figure PM-21] until the track adjustment is correct [Figure PM-19] and [Figure PM-20].

NOTE: Do not remove adjustment fitting unless pressure is released. (See Decrease Track Tension.)

NOTE: If replacement is necessary, always replace adjustment fitting (Item 1) [Figure PM-22] with genuine Bobcat Parts. The fitting is a special fitting designed for high pressure.

TRACK TENSION (CONT'D)

Adjusting Track Tension (Cont'd)

Decrease Track Tension:

Figure PM-22

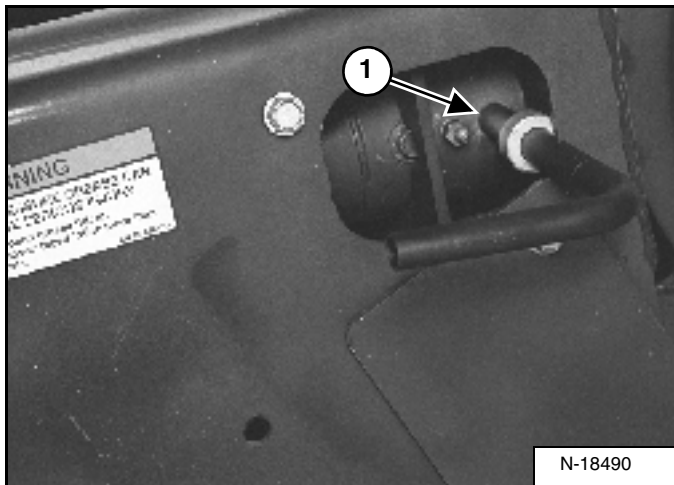

Pressure must be released from the spring and adjustment cylinder to decrease track tension.

Install the bleed tool (MEL-1560) on the bleed fitting (Item 1) [Figure PM-22], adjust and tighten the collar to fit behind the edge of the access hole and the cover.

Figure PM-23

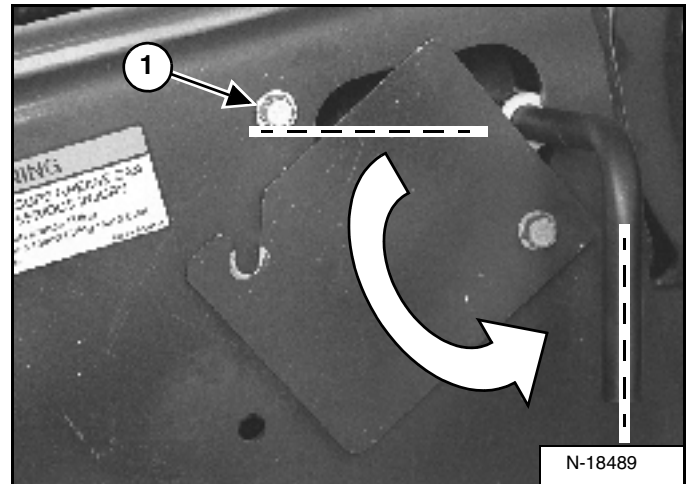

Tighten the cover bolt (Item 1) [Figure PM-23] to secure the tool.

Turn the tool 1/4 turn counterclockwise and let the grease flow into a container. Turn the tool one additional turn to continue to release pressure [Figure PM-23] until the track adjustment is correct [Figure PM-19] and [Figure PM-20].

Raise the loader. Remove the jackstands.

Repeat the procedure for the other track.

Dispose of grease in an environmentally safe manner.

REAR DOOR

Opening And Closing The Rear Door

! WARNING

AVOID INJURY OR DEATH
Never service or adjust the machine when the engine is running unless instructed to do so in the manual.

W-2012-0497

Figure PM-24

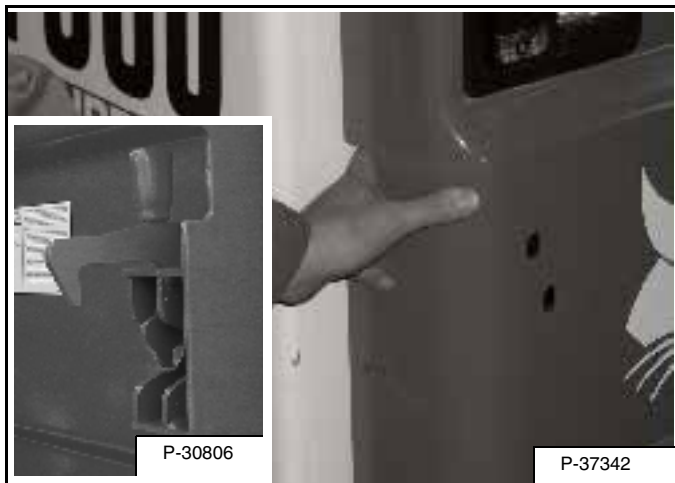

Reach into the slot in the rear door and pull the latch handle [Figure PM-24].

Pull the rear door open.

Figure PM-25

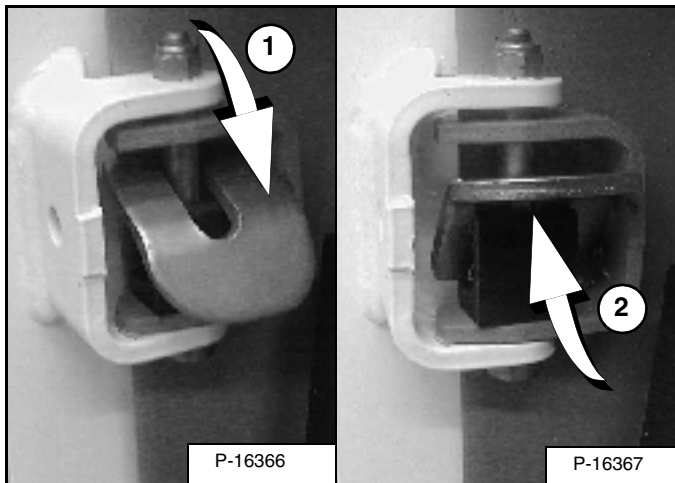

Move the door stop into the engaged position (Item 1) [Figure PM-25] to hold the door in the open position.

Move to disengaged position (Item 2) [Figure PM-25] to allow the door to close.

! WARNING

Keep the rear door closed when operating the machine. Failure to do so could seriously injure a bystander.

W-2020-1285

Adjusting The Rear Door

Figure PM-26

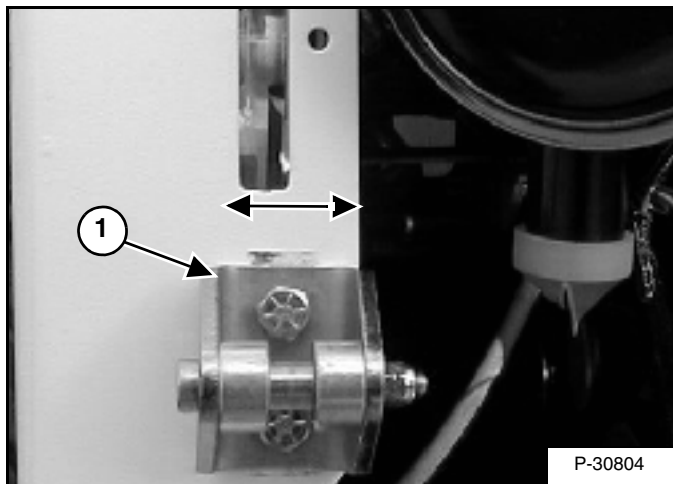

The door latch (Item 1) [Figure PM-26] can be adjusted side to side for alignment with the door latch mechanism.

Close the rear door before operating the loader.

REAR GRILL

Removing

Open the rear door.

Figure PM-27



Lift and pull the rear grill to remove it from the loader [Figure PM-27].

Installing

Insert the tabs into the slots at the front end of the grill. Lower the grill to the frame.

Close the rear door.

HEATING SYSTEM

Cleaning And Maintenance

The heating system requires regular inspection and maintenance. (See SERVICE SCHEDULE on Page PM-5) for intervals.

Filters

Figure PM-28

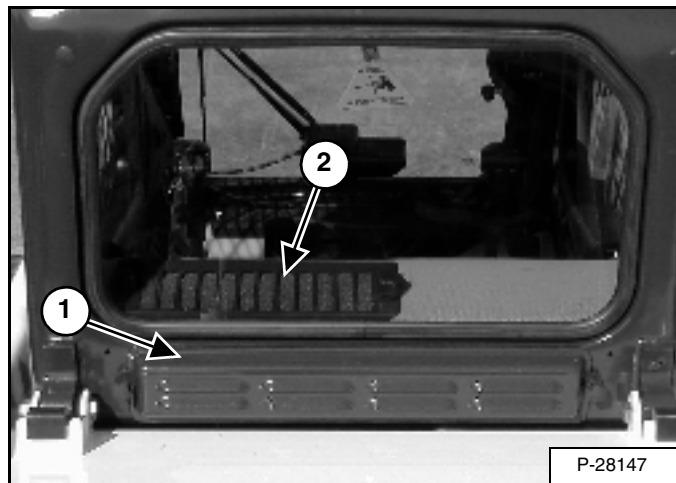

The Fresh Air Filter is located below the rear window of the cab (Item 1) [Figure PM-28].

Remove the knobs and remove the filter housing.

Shake the filter or use low air pressure to remove dirt. The filter can be cleaned several times in this manner then it must be replaced.

Reinstall the filter housing.

The Recirculation Filter is located in front of the rear window inside the cab (Item 2) [Figure PM-28].

Remove the clamping knobs, grill and filter.

Shake the filter or use low air pressure to remove dirt. The filter can be cleaned several times in this manner then it must be replaced.

Troubleshooting

If the fan does not run, check the fuse (See ELECTRICAL SYSTEM on Page PM-23).

AIR CLEANER SERVICE

Replacing Filter Elements

Figure PM-29

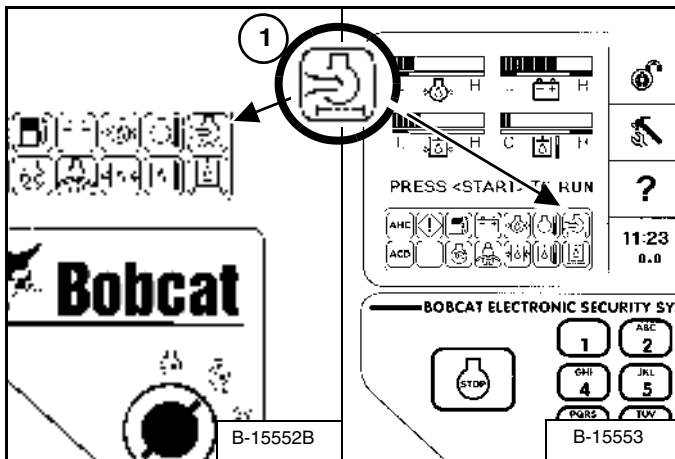

It is important to change the air filter element only when the Air Cleaner Icon in the right panel is ON (Item 1) [Figure PM-29] and you hear three beeps from the alarm.

Replace the inner filter every third time the outer filter is replaced or as indicated.

Figure PM-30

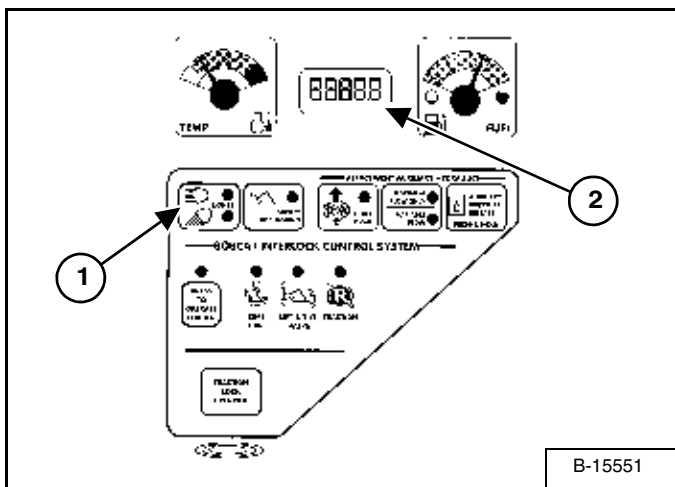

Press and hold the LIGHT Button (Item 1) [Figure PM-30] for two seconds.

If the filter element needs replacement, the CODE [01-17] (Air Filter Plugged) will show in the HOURMETER / CODE DISPLAY (Item 2) [Figure PM-30].

Outer Filter

Figure PM-31

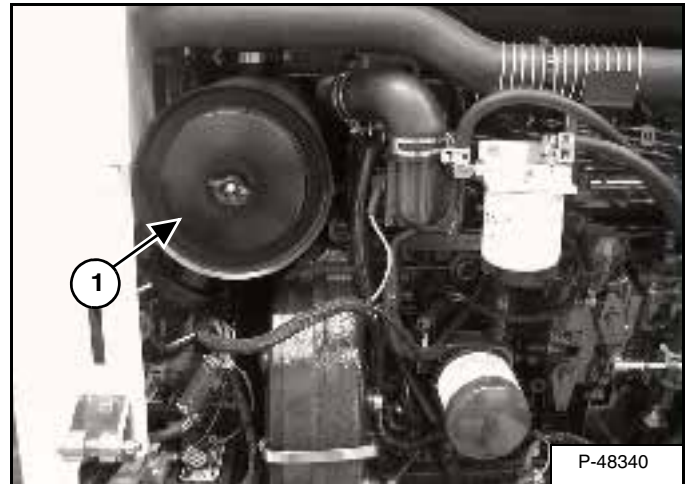

Remove the wing nut and remove the dust cover (Item 1) [Figure PM-31].

Figure PM-32

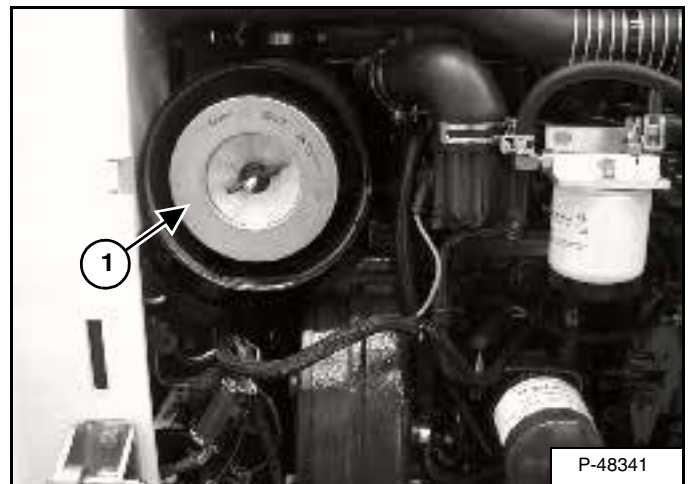

Remove the wing nut and pull the outer filter element (Item 1) [Figure PM-32] out and discard.

NOTE: Make sure all sealing surfaces are free of dirt and debris.

Install new filter. Push all the way in until it contacts the base of the housing. Install wing nut.

Install the dust cover and the wing nut [Figure PM-31].

AIR CLEANER (CONT'D)

Replacing Filter Elements (Cont'd)

Inner Filter

Only replace the inner filter element under the following conditions:

- Replace the inner filter element every *third* time the outer filter is replaced.
- After the outer element has been replaced, start the engine and run at full RPM. If the HOURMETER / CODE DISPLAY shows **[01-17]** (Air Filter Plugged), replace the inner filter element.

Figure PM-33

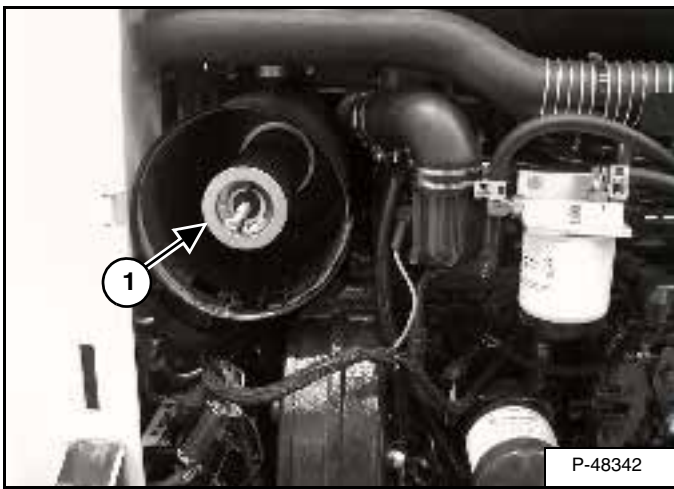

Remove the inner filter element (Item 1) [Figure PM-33].

NOTE: Make sure all sealing surfaces are free of dirt and debris.

Install the new inner element [Figure PM-33].

Install the dust cover and the wing nut.

FUEL SYSTEM

Fuel Specifications

Use only clean, high quality diesel fuel, Grade No. 2 or Grade No. 1.

The following is one suggested blending guideline which should prevent fuel gelling during cold temperatures:

TEMP C (F)	No. 2	No. 1
-9° (+15°)	100%	0%
Down to -29° (-20°)	50%	50%
Below -29° (-20°)	0%	100%

Contact your fuel supplier for local recommendations.

Filling The Fuel Tank



Stop and cool the engine before adding fuel. **NO SMOKING!** Failure to obey warnings can cause an explosion or fire.

W-2063-0887

Open the rear door.

Figure PM-34

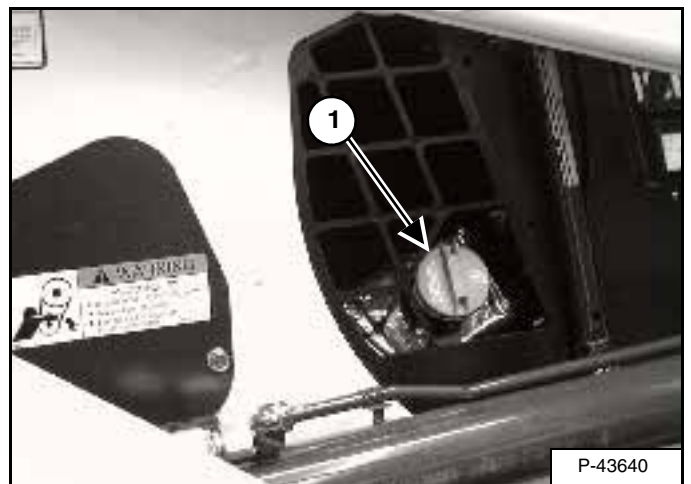

Remove the fill cap (Item 1) [Figure PM-34].

Use a clean, approved safety container to add fuel of the correct specification. Add fuel only in an area that has free movement of air and no open flames or sparks **NO SMOKING.**

Install and tighten the fuel cap (Item 1) [Figure PM-34].

FUEL SYSTEM (CONT'D)

Fuel Filter

For the service interval for removing water from, or replacing the fuel filter (See SERVICE SCHEDULE on Page PM-5).

Figure PM-35

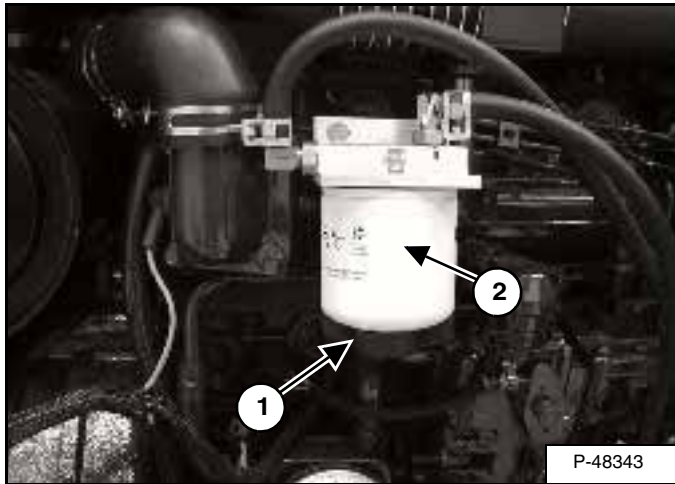

Loosen the drain (Item 1) [Figure PM-35] at the bottom of the filter element to remove water from the filter.

Remove the filter element (Item 2) [Figure PM-35].

Clean the area around the filter housing. Put clean oil on the seal of the new filter element. Install the fuel filter, and hand tighten.

Remove air from the fuel system. (See Removing Air From The Fuel System.)

WARNING

Always clean up spilled fuel or oil. Keep heat, flames, sparks or lighted tobacco away from fuel and oil. Failure to use care around combustibles can cause explosion or fire which can result in injury or death.

W-2103-1285

Removing Air From The Fuel System

After replacing the filter element or when the fuel tank has run out of fuel, the air must be removed from the fuel system before starting the engine.

WARNING

Diesel fuel or hydraulic fluid under pressure can penetrate skin or eyes, causing serious injury or death. Fluid leaks under pressure may not be visible. Use a piece of cardboard or wood to find leaks. Do not use your bare hand. Wear safety goggles. If fluid enters skin or eyes, get immediate medical attention from a physician familiar with this injury.

W-2072-0496

Figure PM-36

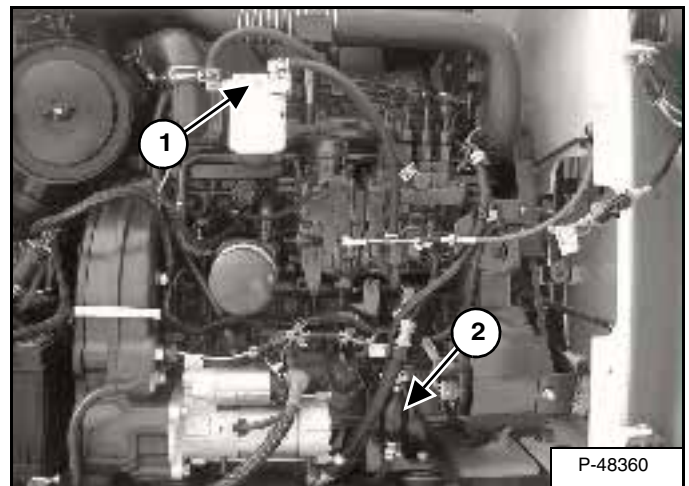

Open the vent (Item 1) [Figure PM-36] on the fuel filter housing.

Squeeze the hand pump (priming bulb) (Item 2) [Figure PM-36] until fuel flows from the vent with no air bubbles.

Close the vent (Item 1) [Figure PM-36].

ENGINE LUBRICATION SYSTEM

Checking Engine Oil

Check the engine oil level every day before starting the engine for the work shift.

Figure PM-37

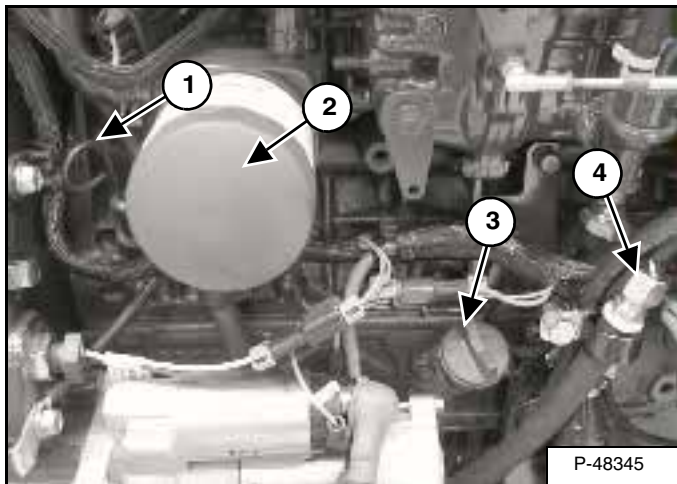

Open the rear door and remove the dipstick (Item 1) [Figure PM-37].

Keep the oil level between the marks on the dipstick.

Figure PM-38

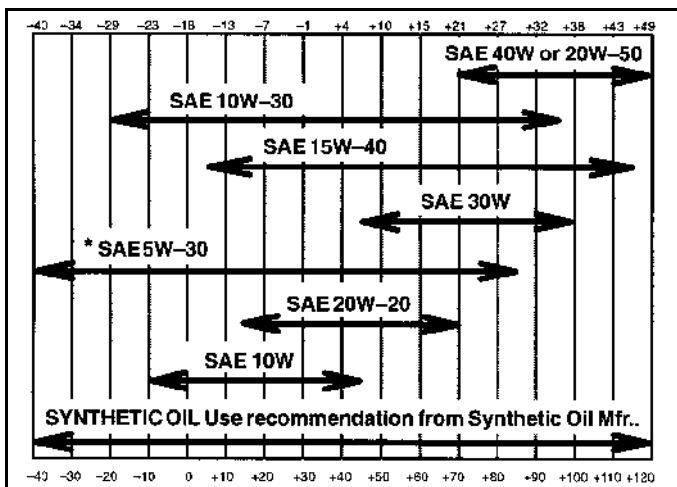

Use good quality motor oil that meets API Service Classification of CD or better [Figure PM-38].

Replacing The Oil And Filter

For the service interval for replacing the engine oil and filter (See SERVICE SCHEDULE on Page PM-5).

Run the engine until it is at operating temperature. Stop the engine.

Open the rear door and remove the drain hose from its storage position (Item 4) [Figure PM-37].

Figure PM-39

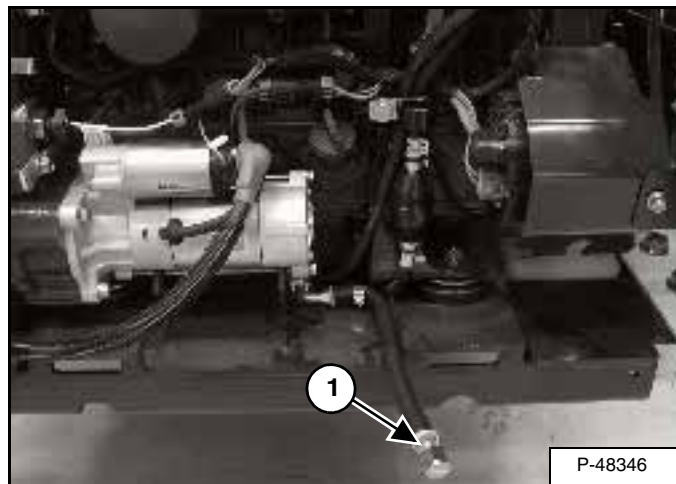

Remove the drain plug (Item 1) [Figure PM-39] and drain the oil into a container and recycle or dispose of used oil in an environmentally safe manner.

Reinstall the drain plug.

Remove the oil filter (Item 2) [Figure PM-37] and clean the filter housing surface.

Use genuine Bobcat filter only.

Put oil on the new filter gasket, install the filter and hand tighten.

Remove the fill cap (Item 3) [Figure PM-37].

Put oil in the engine (See loader specifications (T250) on Page SPEC-3), for the correct quantity.

Start the engine and let it run for several minutes. Stop the engine and check for leaks at the filter.

Remove the dipstick (Item 1) [Figure PM-37] and check the oil level.

Add oil as needed if it is not at the top mark on the dipstick.

Install the dipstick and close the rear door.



Always clean up spilled fuel or oil. Keep heat, flames, sparks or lighted tobacco away from fuel and oil. Failure to use care around combustibles can cause explosion or fire which can result in injury or death.

W-2103-1285

ENGINE COOLING SYSTEM

Cleaning The Cooling System

WARNING

Wear safety glasses to prevent eye injury when any of the following conditions exist:

- When fluids are under pressure.
- Flying debris or loose material is present.
- Engine is running.
- Tools are being used.

W-2019-1285

Check the cooling system every day to prevent overheating, loss of performance or engine damage.

Remove the rear grill. (See REAR GRILL on Page PM-17.)

Figure PM-40

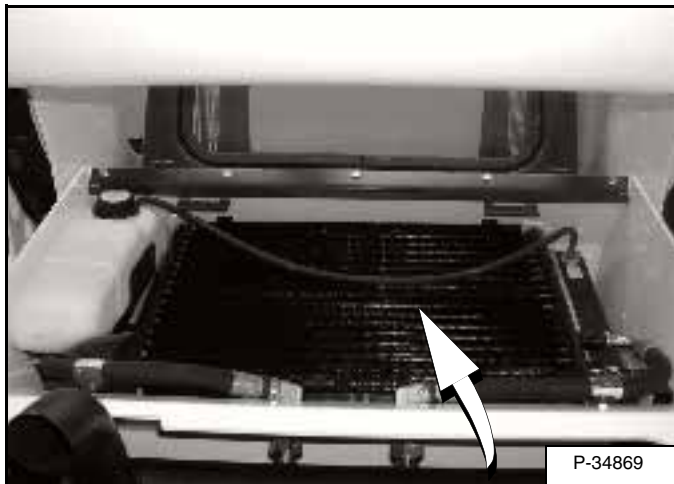

Use air pressure or water pressure to clean the top of the oil cooler [Figure PM-40].

NOTE: Be careful when raising and lowering the oil cooler so that the oil cooler does not fall on the radiator and damage the fins.

Figure PM-41

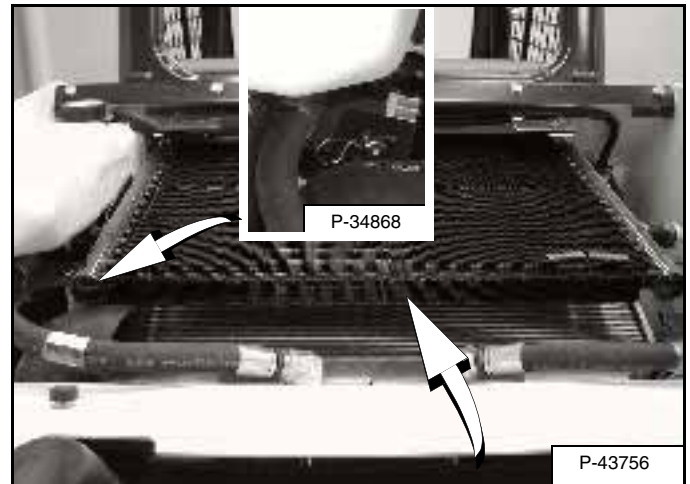

Raise the overflow tank slightly and remove the two fasteners (Inset) [Figure PM-41].

Raise the oil cooler and use air pressure or water pressure to clean the top of the radiator [Figure PM-41].

Lower the oil cooler, install the fasteners and lower the overflow tank.

Check the cooling system for leaks.

Figure PM-42

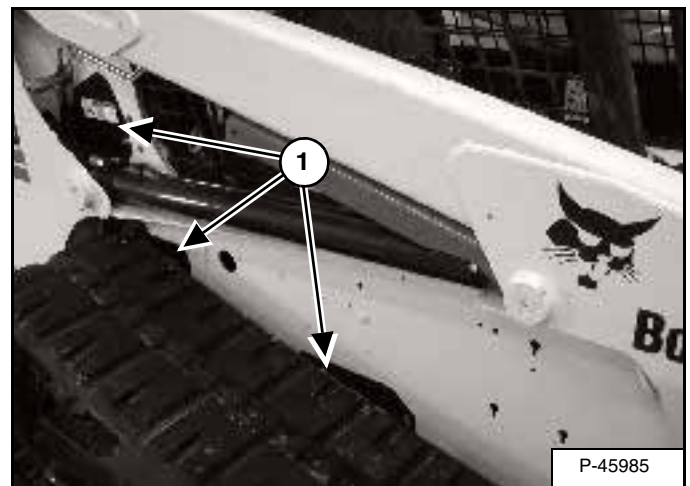

NOTE: All access covers (Item 1) [Figure PM-42] (both sides) must be in place to ensure correct air flow through the oil cooler which will ensure cooling for engine and hydraulic system.

ELECTRICAL SYSTEM

Description

Figure PM-43

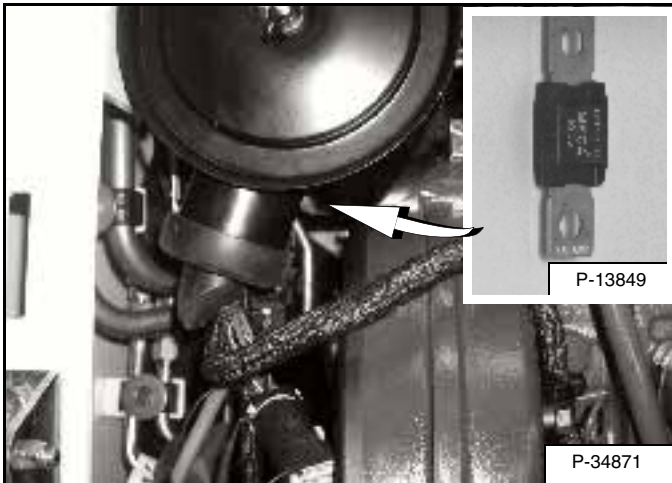

The loader has a 12 volt, negative ground alternator charging system. The electrical system is protected by fuses located in the cab on the steering control panel, and a 100 amp master fuse [Figure PM-43] in the engine compartment on the left side of the engine, under the air cleaner. The fuses will protect the electrical system when there is an electrical overload. The reason for the overload must be found before starting the engine again.

Cleaning Battery And Terminals

Figure PM-44

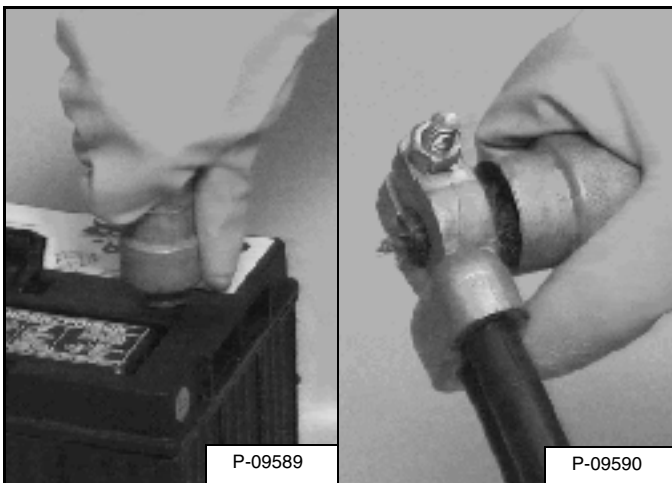

The battery cables must be clean and tight [Figure PM-44]. Check electrolyte level in the battery. Add distilled water as needed. Remove acid or corrosion from battery and cables with sodium bicarbonate (baking soda) and water solution.

Put Battery Saver (6664458) or grease on the battery terminals and cable ends to prevent corrosion.

Fuse Location



Batteries contain acid which burns eyes and skin on contact. Wear goggles, protective clothing and rubber gloves to keep acid off body.

In case of acid contact, wash immediately with water. In case of eye contact get prompt medical attention and wash eye with clean, cool water for at least 15 minutes.

If electrolyte is taken internally drink large quantities of water or milk! DO NOT induce vomiting. Get prompt medical attention.

W-2065-1296

Figure PM-45

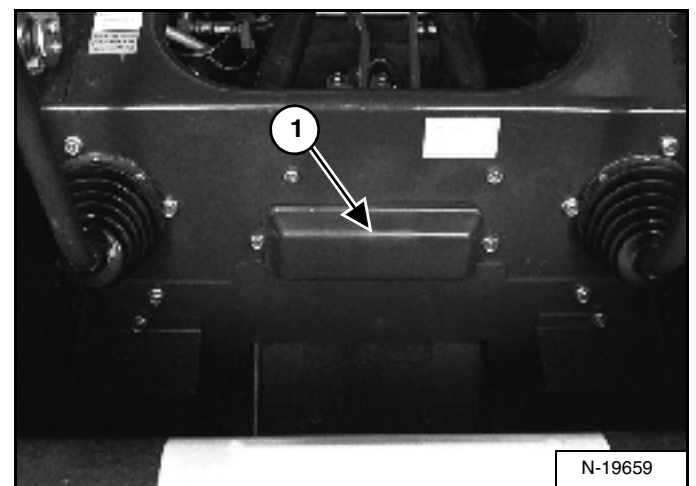

The electrical system is protected from overload by fuses and relays under the fuse panel cover (Item 1) [Figure PM-45]. A decal is inside the cover to show location and amp ratings.

Remove the cover to check or replace the fuses.

ELECTRICAL SYSTEM (CONT'D)

Fuse Location (Cont'd)

Figure PM-46

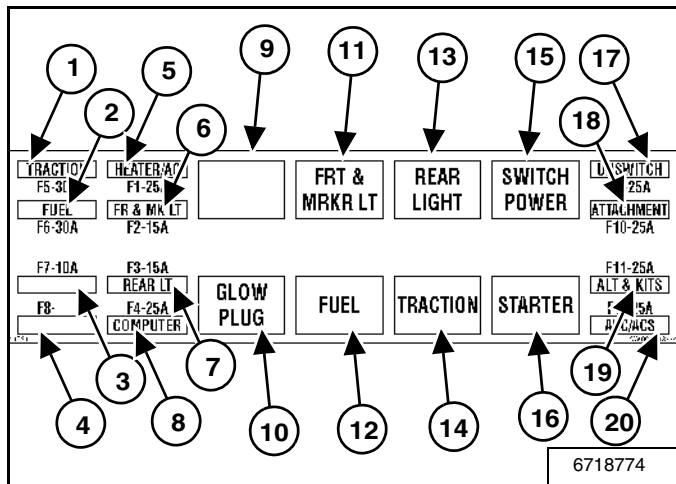

The location and sizes are shown below and in [Figure PM-46].

REF	DESCRIPTION	AMP	REF	DESCRIPTION	AMP
1	Traction	30	11	Front & Marker Lights	R
2	Fuel Shutoff	30	12	Fuel Shutoff	R
3	Not Used	10	13	Rear Lights	R
4	Not Used	--	14	Traction	R
5	Heater & Air Conditioner	25	15	Switch Power	R
6	Front & Marker Lights	15	16	Starter	R
7	Rear Lights	15	17	Unswitched Attach. (Acc. Plug)	25
8	Bobcat Controller	25	18	Switched Attachments	25
9	Not Used	--	19	Alternator & Accessories	25
10	Glow Plugs	R	20	AHC/ACS	25

R = Relay

Using A Booster Battery (Jump Starting)

If it is necessary to use a booster battery to start the engine, BE CAREFUL! There must be one person in the operator's seat and one person to connect and disconnect the battery cables.

The key switch must be OFF (*Standard Panel*) OR the STOP Button must be pressed (*Deluxe Panel*). The booster battery must be 12 volt.



WARNING

Batteries contain acid which burns eyes and skin on contact. Wear goggles, protective clothing and rubber gloves to keep acid off body.

In case of acid contact, wash immediately with water. In case of eye contact get prompt medical attention and wash eye with clean, cool water for at least 15 minutes.

If electrolyte is taken internally drink large quantities of water or milk! DO NOT induce vomiting. Get prompt medical attention.

W-2065-1296



WARNING

Keep arcs, sparks flames and lighted tobacco away from batteries. When jumping from booster battery make final connection (negative) at engine frame.

Do not jump start or charge a frozen or damaged battery. Warm battery to 16°C (60°F) before connecting to a charger. Unplug charger before connecting or disconnecting cables to battery. Never lean over battery while boosting, testing or charging.

Battery gas can explode and cause serious injury.

W-2066-1296

ELECTRICAL SYSTEM (CONT'D)

Using A Booster Battery (Jump Starting) (Cont'd)

Figure PM-47

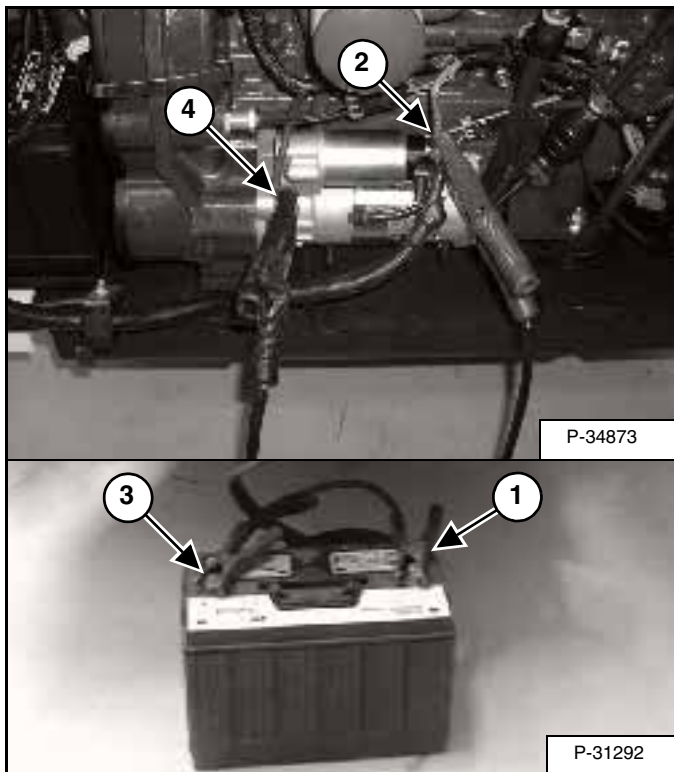

Connect the end of the first cable (Item 1) [Figure PM-47] to the positive (+) terminal of the booster battery. Connect the other end of the same cable (Item 2) [Figure PM-47] to the positive terminal on the loader starter.

Connect the end of the second cable (Item 3) [Figure PM-47] to the negative terminal of the booster battery. Connect the other end of the same cable (Item 4) [Figure PM-47] to the engine.

Keep cables away from moving parts. Start the engine. (See Starting the Engine (Standard Panel, Key Switch) on Page OI-27) and (See Starting the Engine (Deluxe Panel, Keyless Start) on Page OI-29).

After the engine has started, remove the ground (-) cable (Item 4) [Figure PM-47] first. Remove the cable from the positive terminal (Item 2) [Figure PM-47].

IMPORTANT

Damage to the alternator can occur if:

- Engine is operated with battery cables disconnected.
- Battery cables are connected when using a fast charger or when welding on the loader. (Remove both cables from the battery.)
- Extra battery cables (booster cables) are connected wrong.

I-2023-1285

ELECTRICAL SYSTEM (CONT'D)

Removing And Installing The Battery

WARNING

Batteries contain acid which burns eyes and skin on contact. Wear goggles, protective clothing and rubber gloves to keep acid off body.

In case of acid contact, wash immediately with water. In case of eye contact get prompt medical attention and wash eye with clean, cool water for at least 15 minutes.

If electrolyte is taken internally drink large quantities of water or milk! DO NOT induce vomiting. Get prompt medical attention.

W-2065-1296

Open the rear door.

Removing And Installing The Battery (Cont'd)

Figure PM-48

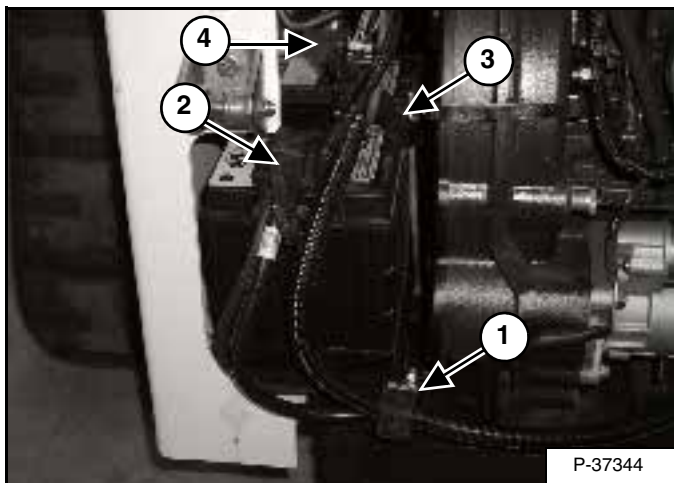

Remove the harness clamp (Item 1) [Figure PM-48].

Disconnect the negative (-) cable (Item 2) [Figure PM-48].

Remove the battery hold down clamp (Item 3) [Figure PM-48].

Disconnect the positive (+) cable (Item 4) [Figure PM-48] from the battery.

Remove the battery from the loader.

Figure PM-49

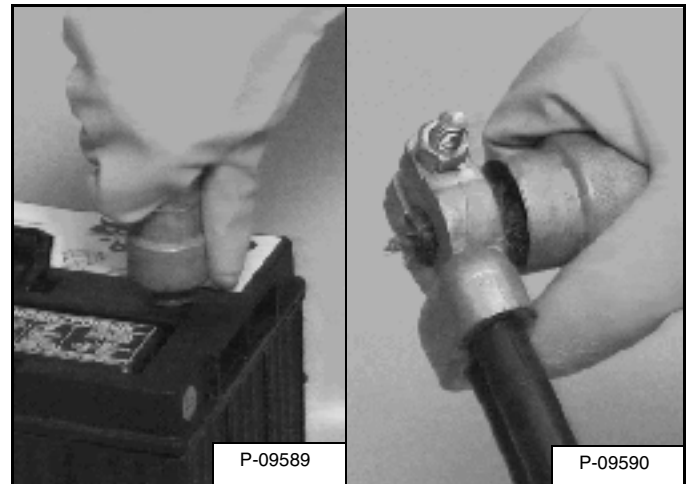

Always clean the battery terminals and cable ends when installing a new or used battery [Figure PM-49].

When installing the battery in the loader, do not touch any metal parts with the battery terminals.

Connect the negative (-) cable last to prevent sparks.

Connect and tighten the battery cables.

Install and tighten the battery hold down.

WARNING

Keep arcs, sparks flames and lighted tobacco away from batteries. When *jumping* from booster battery make final connection (negative) at engine frame.

Do not jump start or charge a frozen or damaged battery. Warm battery to 16°C (60°F) before connecting to a charger. Unplug charger before connecting or disconnecting cables to battery. Never lean over battery while boosting, testing or charging.

Battery gas can explode and cause serious injury.

W-2066-1296

HYDRAULIC / HYDROSTATIC SYSTEM

Checking And Adding Fluid

Use only recommended fluid in the hydraulic system. (See loader specifications (T250) on Page SPEC-3.)

Put the loader on a level surface, lower the lift arms and tilt the Bob-Tach fully back.

Stop the engine.

Figure PM-50

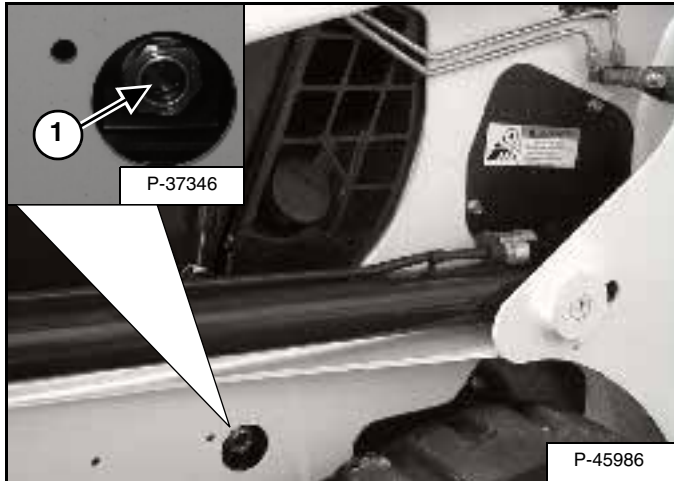

Check the fluid level in sight gauge (Item 1) [Figure PM-50].

Figure PM-51

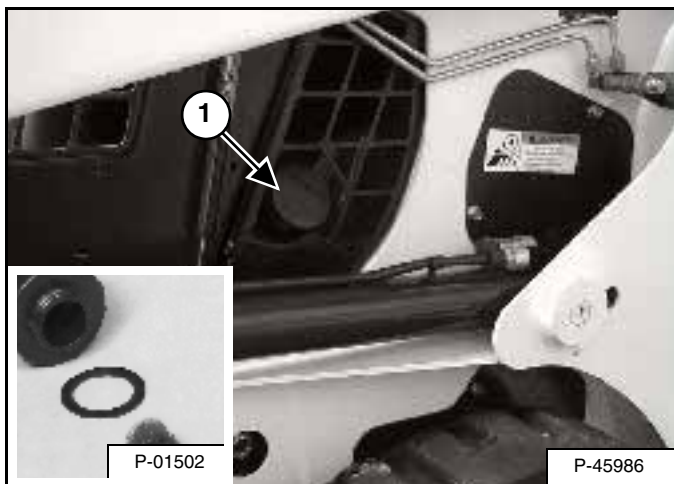

Remove the fill cap (Item 1) [Figure PM-51].

Add fluid as needed to bring the level to the center of the sight gauge.

NOTE: Before installing the fill cap, make sure the rubber gasket is installed on fill cap (Inset) [Figure PM-51].

Install the fill cap [Figure PM-51].

Replacing Hydraulic/Hydrostatic Filter

For the correct service interval (See SERVICE SCHEDULE on Page PM-5).

Raise the operator cab (See Raising The Operator Cab on Page PM-8).

Figure PM-52

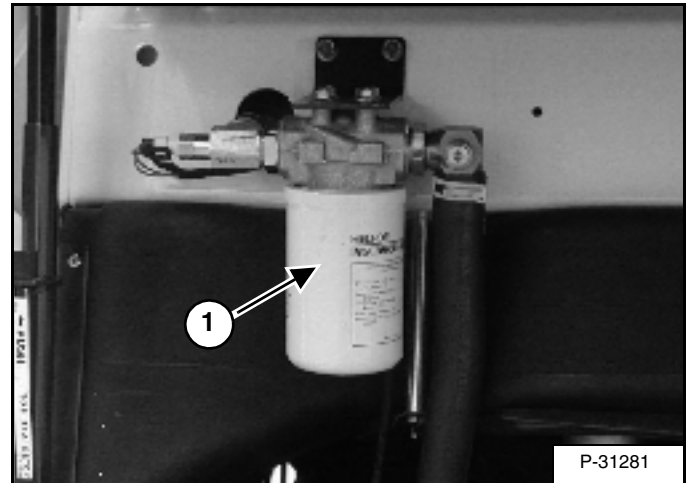

Remove the filter (Item 1) [Figure PM-52].

Clean the surface of the filter housing where the filter seal contacts the housing.

Put clean oil on the seal of the new filter element. Install and hand tighten the filter element.

WARNING

Diesel fuel or hydraulic fluid under pressure can penetrate skin or eyes, causing serious injury or death. Fluid leaks under pressure may not be visible. Use a piece of cardboard or wood to find leaks. Do not use your bare hand. Wear safety goggles. If fluid enters skin or eyes, get immediate medical attention from a physician familiar with this injury.

W-2072-0496

Lower the operator cab (See Lowering The Operator Cab on Page PM-9).

Start the engine and operate the loader hydraulic controls.

Stop the engine and check for leaks at the filter.

HYDRAULIC / HYDROSTATIC SYSTEM (CONT'D)

Replacing Hydraulic/Hydrostatic Filter (Cont'd)

Check the fluid level in the reservoir and add as needed.

WARNING

Always clean up spilled fuel or oil. Keep heat, flames, sparks or lighted tobacco away from fuel and oil. Failure to use care around combustibles can cause explosion or fire which can result in injury or death.

W-2103-1285

Replacing Hydraulic Fluid and Case Drain Filters

For the correct service interval (See SERVICE SCHEDULE on Page PM-5).

Replace the fluid if it becomes contaminated or after major repair.

Always replace the hydraulic/hydrostatic filter (See Replacing Hydraulic/Hydrostatic Filter on Page PM-27) and clean the hydraulic fill screen and the case drain filters whenever the hydraulic fluid is replaced.

Remove the fill cap and raise the operator cab (See Raising The Operator Cab on Page PM-8).

Hydraulic Fill Screen

Figure PM-53

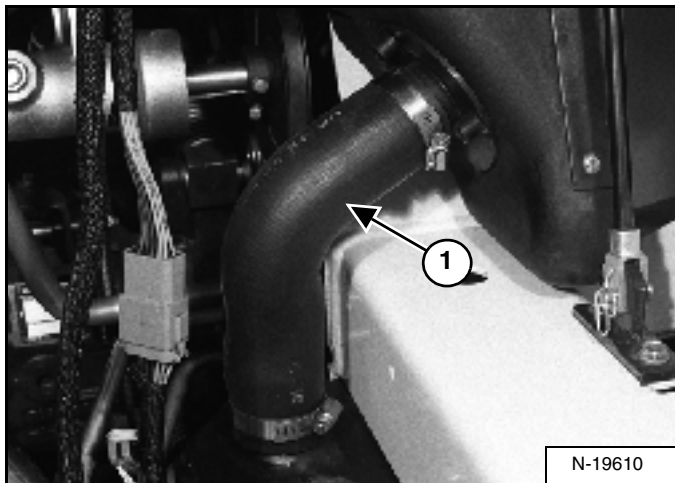

Remove the two hose clamps and remove the hose (Item 1) [Figure PM-53].

Figure PM-54

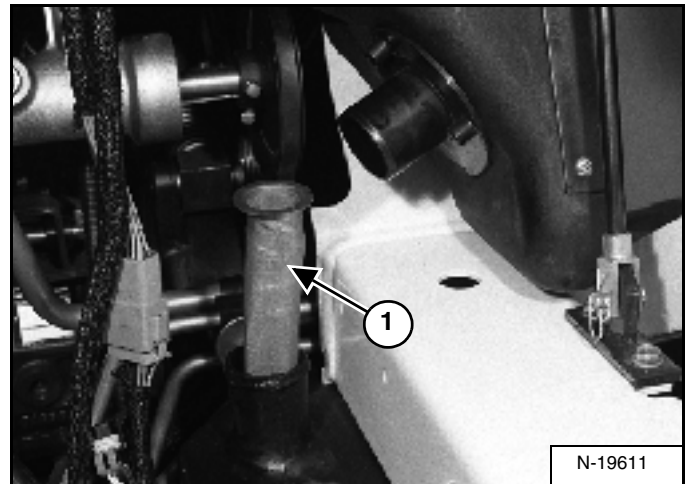

Remove the hydraulic fill screen (Item 1) [Figure PM-54]. Use air pressure to dry the screen.

Install screen, hose and hose clamps.

Figure PM-55

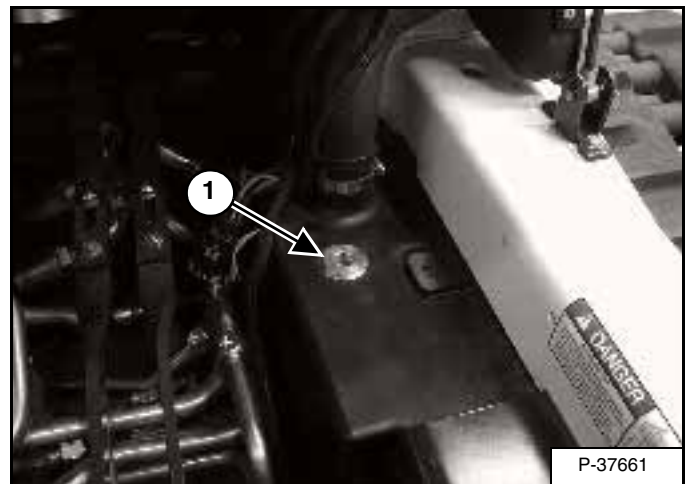

Remove the plug from the top of the reservoir (Item 1) [Figure PM-55]. Use a suction device to remove the fluid.

Recycle or dispose of used fluid in an environmentally safe manner.

WARNING

Always clean up spilled fuel or oil. Keep heat, flames, sparks or lighted tobacco away from fuel and oil. Failure to use care around combustibles can cause explosion or fire which can result in injury or death.

W-2103-1285

HYDRAULIC / HYDROSTATIC SYSTEM (CONT'D)

Replacing Hydraulic Fluid And Case Drain Filters (Cont'd)

Figure PM-56

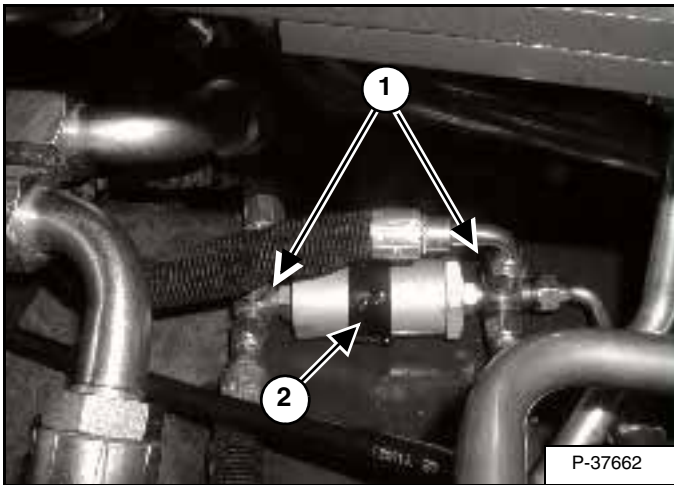

Disconnect the hoses and fittings from the hydrostatic motor case drain filter (Item 1) [Figure PM-56]. Remove the mounting clamp (Item 2) [Figure PM-56] and filter and discard.

Install a new filter; connect and tighten the hoses.

Figure PM-57

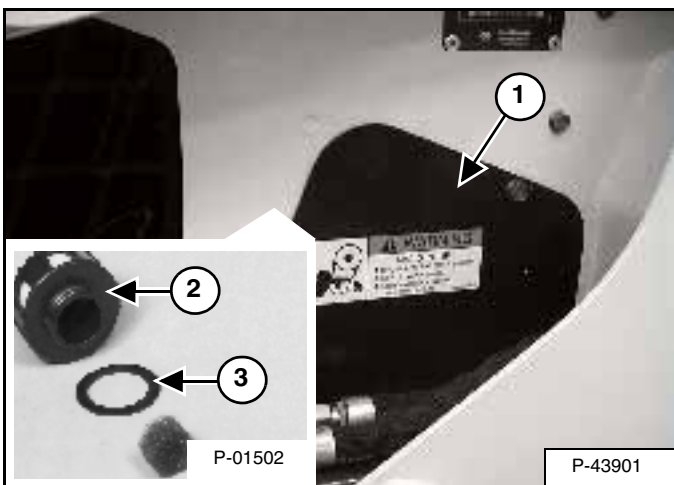

Remove the access panel (Item 1) [Figure PM-57]. (Left Side)

Figure PM-58

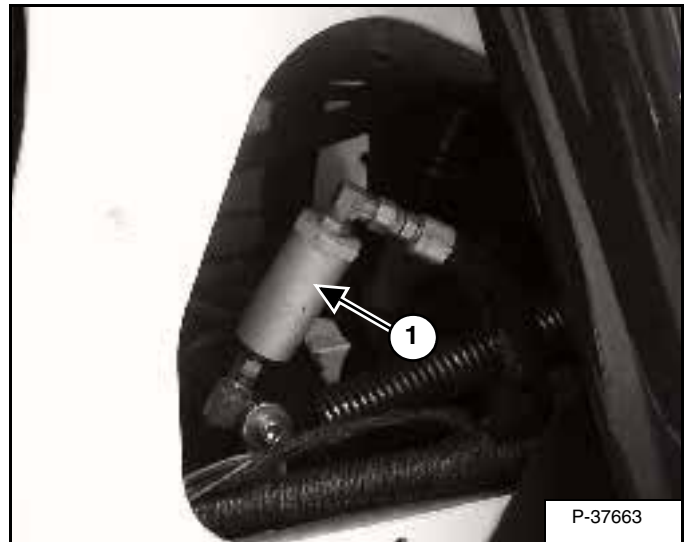

Pull the attachment case drain filter (Item 1) [Figure PM-58] up to the access opening.

Disconnect the hoses and fittings from the filter (Item 1) [Figure PM-58]. Remove and discard the filter.

Install new filter, tighten the hose and fittings and push the filter down into the engine compartment. Install the access cover.

Lower the cab (See Lowering The Operator Cab on Page PM-9).

Add the correct fluid to the reservoir until the fluid level is at the center of the sight gauge. (See Checking And Adding Fluid on Page PM-27.)

Breather Cap

The fill cap is also a breather for the hydraulic/hydrostatic reservoir. Use the correct service interval (See SERVICE SCHEDULE on Page PM-5).

Remove the cap (Item 2) [Figure PM-57] and use clean solvent to remove debris. Dry the cap thoroughly. Install the fill/breather cap.

NOTE: Be sure the rubber gasket (Item 3) [Figure PM-57] is installed on the fill cap.

HYDROSTATIC MOTOR CARRIER OIL

Removing And Replacing Oil

See SERVICE SCHEDULE on Page PM-5 for the correct service interval.

Park the loader so that the plug in the hydrostatic motor carrier is at the bottom

Remove the plug and let the oil drain from the motor carrier.

Figure PM-59

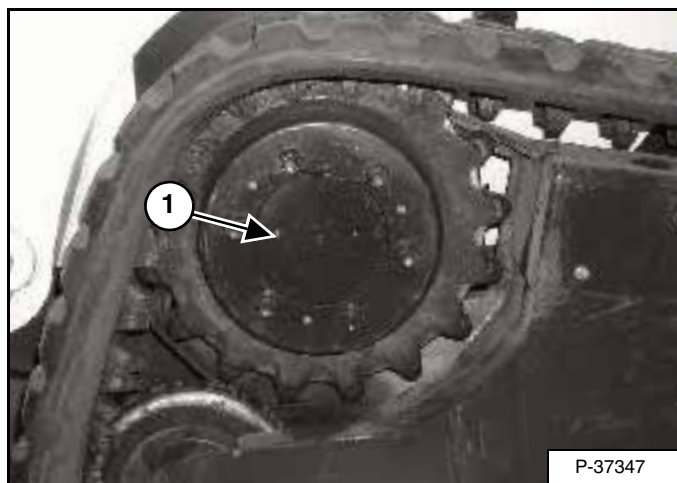

Rotate the motor carrier so that the plug (Item 1) [Figure PM-59] is horizontal with the center of the motor carrier. Add oil (SAE 10W-40) as necessary until it flows from the hole.

Install and tighten the plug to 23 Nm torque.

Repeat for the other hydrostatic motor carrier.

Recycle or dispose of the used oil in an environmentally safe manner.

TRACK ROLLER AND IDLER LUBRICATION

The track rollers and idlers have sealer bearings and do not require lubrication.

FAN GEARBOX

Checking And Maintaining

For the correct service interval (See SERVICE SCHEDULE on Page PM-5).

Raise the operator cab (See Raising The Operator Cab on Page PM-8).

Figure PM-60

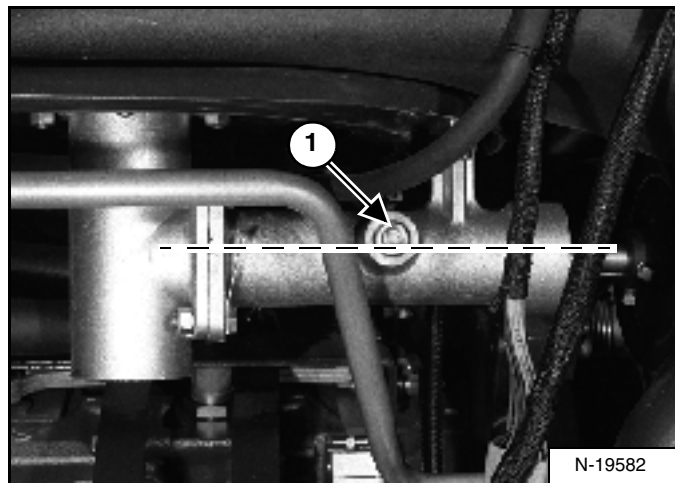

Remove the plug (Item 1) [Figure PM-60].

If the level is low, add SAE 90W gear lubricant through the check plug hole until lubricant flows from the hole.

Install and tighten the plug.

Lower the operator cab. (See Lowering The Operator Cab on Page PM-9.)

DRIVE BELT

Adjusting The Drive Belt

The drive belt does not need adjustment. The belt has a spring loaded idler which is constantly adjusted.

Replacing The Drive Belt

See your Bobcat dealer for Drive Belt replacement.

ALTERNATOR BELT

Adjusting The Alternator Belt

Stop the engine.

Figure PM-61

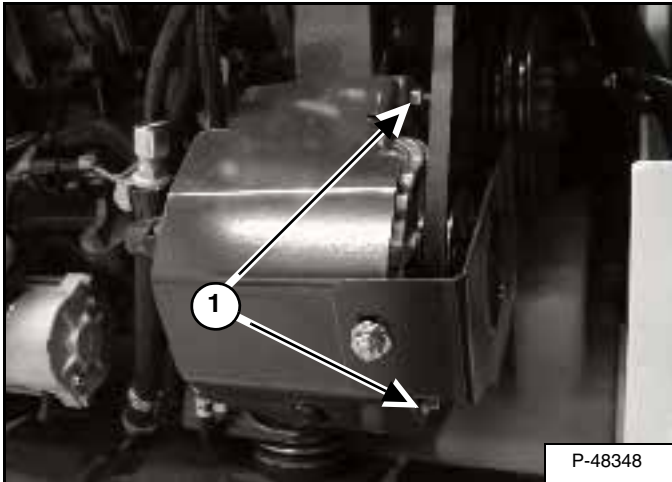

Loosen the alternator mounting and adjustment bolts (Item 1) [Figure PM-61].

Figure PM-62

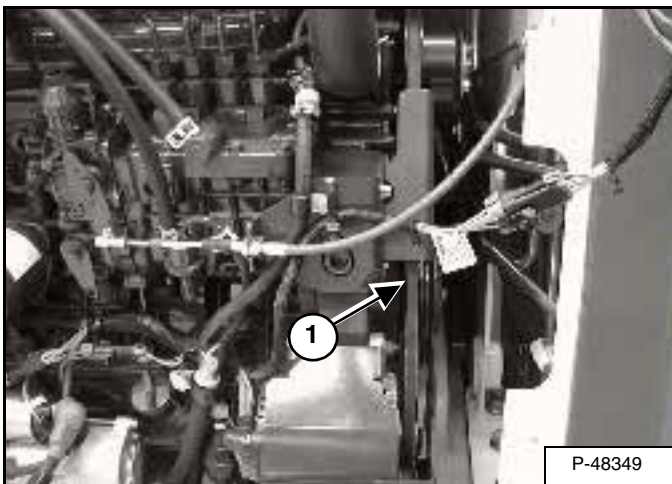

Move the alternator to tighten the belt. The tension is correct when there is 8,0 mm movement at the middle of the belt span (Item 1) [Figure PM-62] with 66 N of force.

Tighten the adjustment and mounting bolts (Item 1) [Figure PM-61].

Adjusting the Air Conditioner Belt

Stop the engine.

Figure PM-63

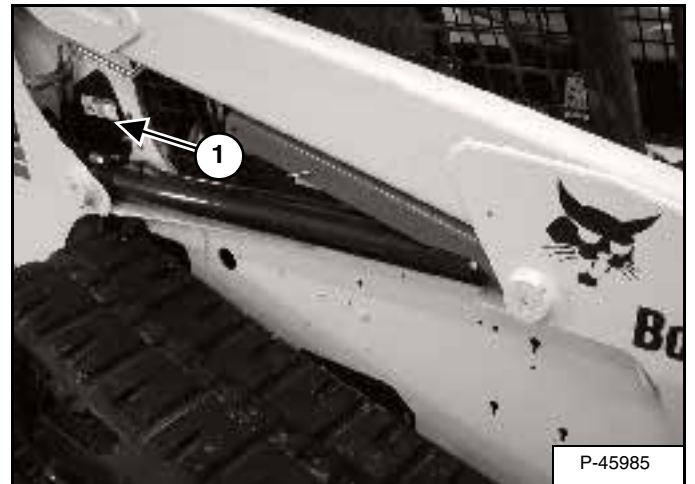

Remove the access cover (Item 1) [Figure PM-63].

Figure PM-64

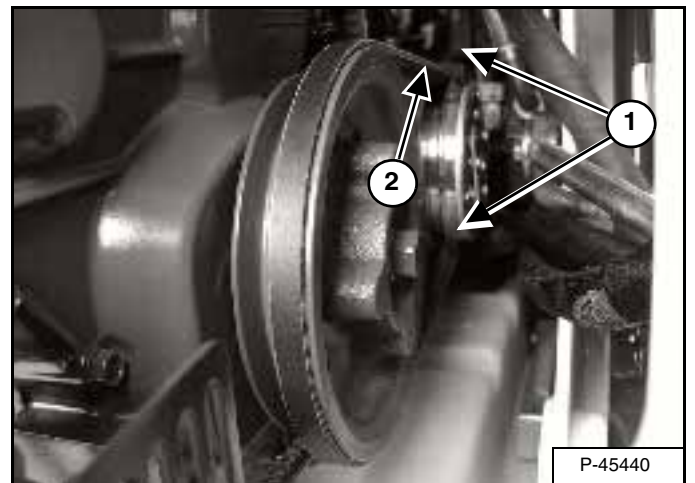

Loosen the mounting and adjustment bolts (Item 1) [Figure PM-64].

Move the air conditioner pump toward the front of machine to tighten the belt. The tension is correct when there is 8,0 mm movement at the middle of the belt span (Item 2) [Figure PM-64] with 66 N of force.

LUBRICATING THE BOBCAT LOADER

Lubrication Locations

Lubricate the loader as specified for the best performance of the loader (See SERVICE SCHEDULE on Page PM-5).

Record the operating hours each time you lubricate the Bobcat loader.

Always use a good quality lithium based multi-purpose grease when you lubricate the loader. Apply the lubricant until extra grease shows.

Lubricate the following:

Figure PM-65

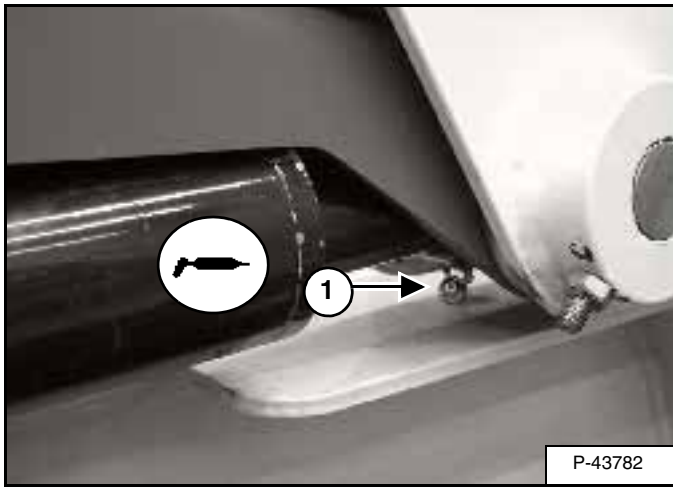

1. Rod End Lift Cylinder (Both Sides) [Figure PM-65].

Figure PM-66

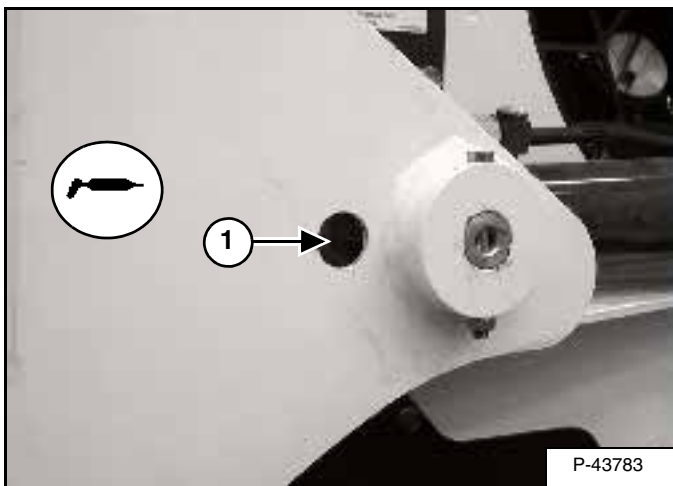

2. Base End Lift Cylinder (Both Sides) [Figure PM-66].

Figure PM-67

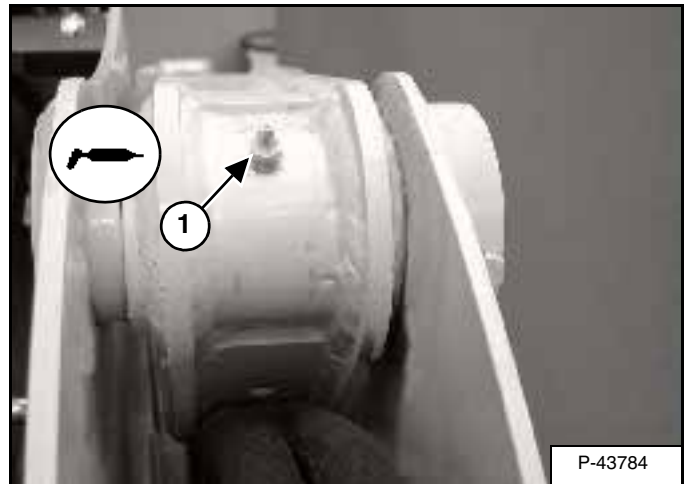

3. Lift Arm Pivot Pin (Both Sides) [Figure PM-67].

Figure PM-68

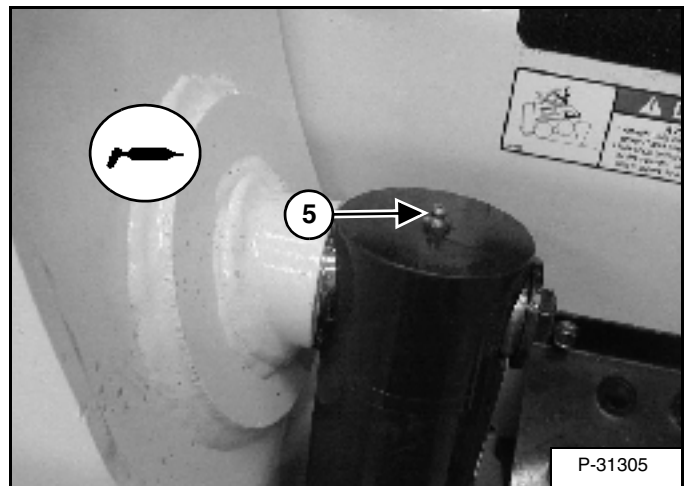

4. Base End Tilt Cylinder (Both Sides) [Figure PM-68].

LUBRICATION OF THE LOADER (CONT'D)

Lubrication Locations (Cont'd)

Figure PM-69

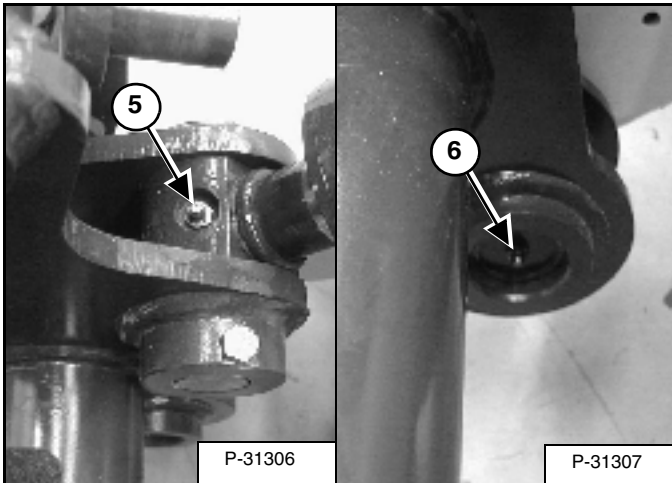

5. Rod End Tilt Cylinder (Both Sides) [Figure PM-69].

6. Bob-Tach Pivot Pin (Both Sides) [Figure PM-69].

Figure PM-70

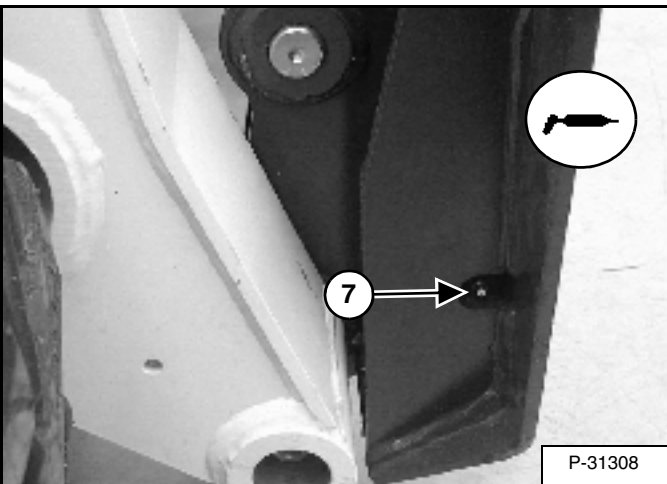

7. Bob-Tach Wedge (Both Sides) [Figure PM-70].

Figure PM-71

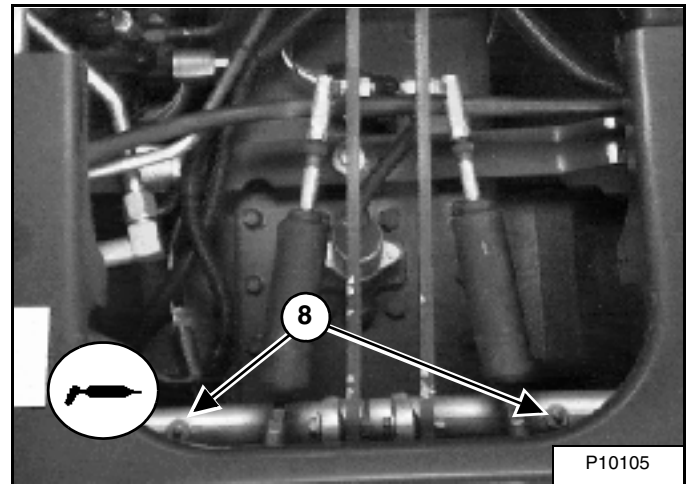

8. 250 Hours: Steering Lever Shaft (three) [Figure PM-71].

PIVOT PINS

Inspection And Maintenance

Figure PM-72

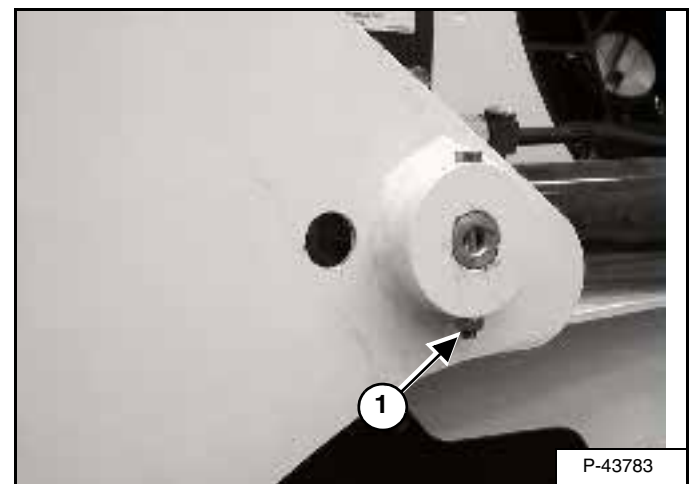

All lift arm and cylinder pivots have a large pin held in position with a retainer bolt and lock nut (Item 1) [Figure PM-72].

Check that the lock nuts are tightened to 34-38 Nm torque.

BOB-TACH (HAND LEVER)

Inspection And Maintenance

Figure PM-73

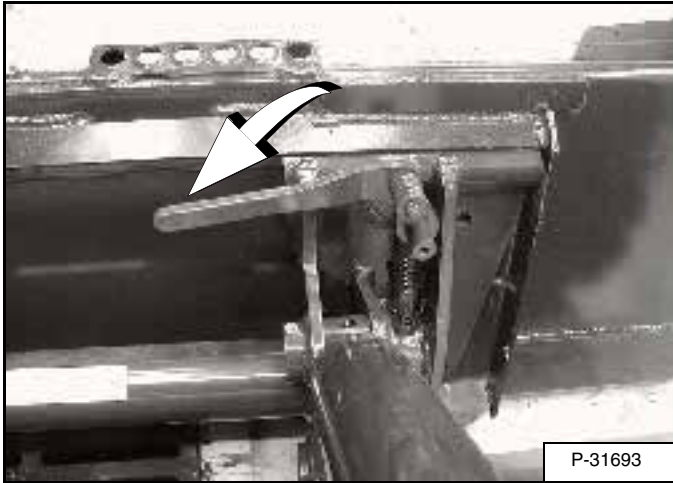

Move the Bob-Tach levers down to engage the wedges [Figure PM-73].

The levers and wedges must move freely.

WARNING

Bob-Tach wedges must extend through the holes in attachment. Levers must be fully down and locked. Failure to secure wedges can allow attachment to come off and cause injury or death.

W-2102-0588

Figure PM-74

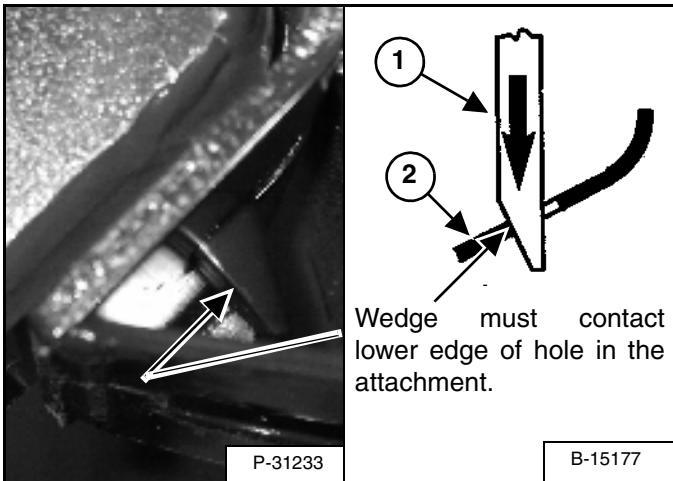

The wedges (Item 1) [Figure PM-74] must extend through the holes in the attachment mounting frame.

The spring loaded wedge (Item 1) [Figure PM-74] must contact the lower edge of the hole in the attachment (Item 2) [Figure PM-74].

If the wedge does not contact the lower edge of the hole [Figure PM-74], the attachment will be loose and can come off the Bob-Tach.

Figure PM-75

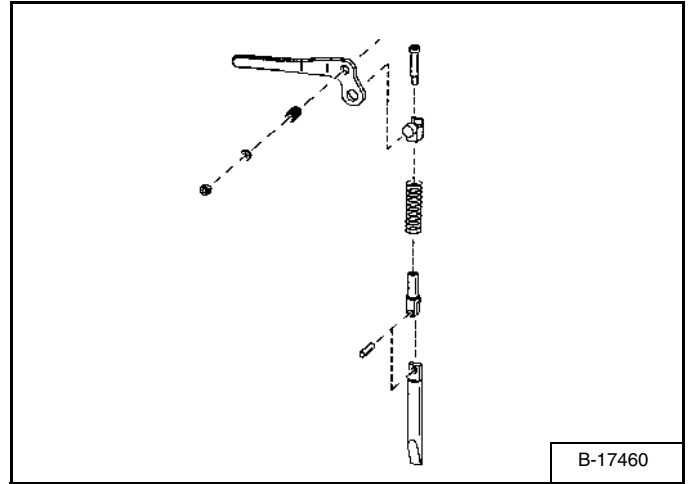

Inspect the mounting frame on the attachment and Bob-Tach, linkages and wedges for excessive wear or damage [Figure PM-75]. Replace any parts that are damaged, bent or missing. Keep all fasteners tight.

Look for cracked welds. Contact your Bobcat dealer for repair or replacement parts.

Lubricate the wedges (See SERVICE SCHEDULE on Page PM-5) and (See LUBRICATING THE BOBCAT LOADER on Page PM-32).

BOB-TACH (POWER) (OPTION)

Inspection And Maintenance

Figure PM-76

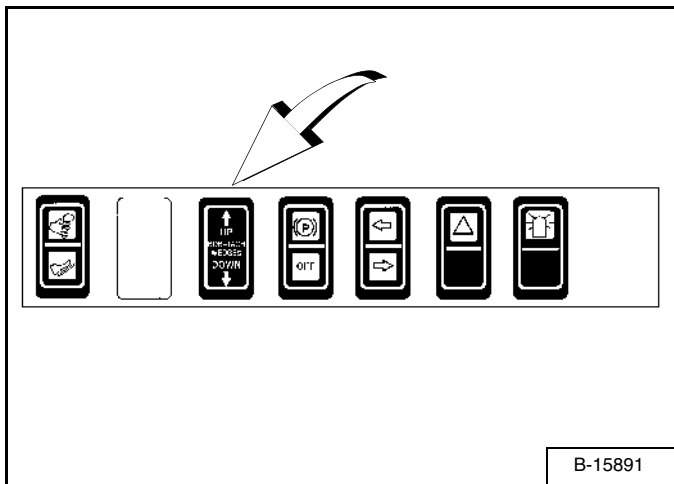

Push and hold the BOB-TACH “WEDGES UP” switch [Figure PM-76] until wedges are fully raised. Push and hold the BOB-TACH “WEDGES DOWN” switch [Figure PM-76] until the wedges are fully down.

The levers and wedges must move freely.

WARNING

Bob-Tach wedges must extend through the holes in attachment. Levers must be fully down and locked. Failure to secure wedges can allow attachment to come off and cause injury or death.

W-2102-0588

Figure PM-77

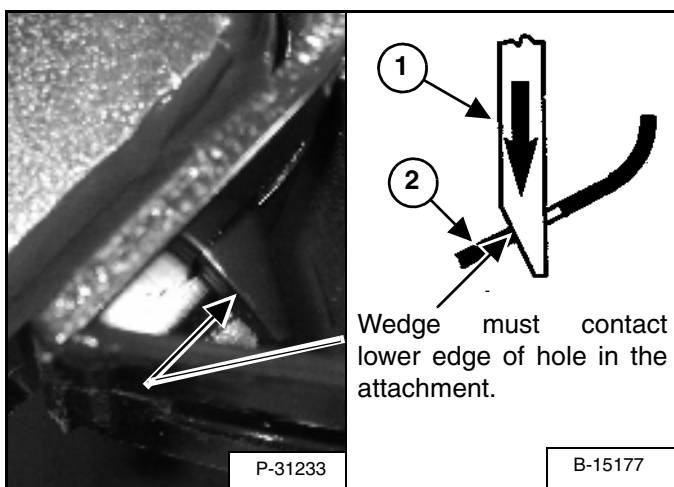

The wedges must extend through the holes in the attachment mounting frame (Item 1) [Figure PM-77].

The spring loaded wedge (Item 1) must contact the lower edge of the hole in the attachment (Item 2) [Figure PM-77].

If the wedge does not contact the lower edge of the hole [Figure PM-77], the attachment will be loose and can come off the Bob-Tach.

Figure PM-78

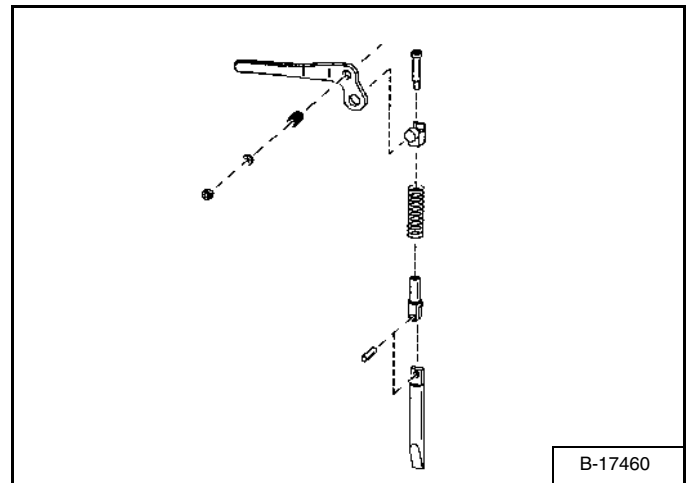

Inspect the mounting frame on the attachment and the Bob-Tach, linkages and wedges for excessive wear or damage [Figure PM-78]. Replace any parts that are damaged, bent, or missing. Keep all fasteners tight.

Look for cracked welds. Contact your Bobcat dealer for repair or replacement parts.

Lubricate the wedges (See SERVICE SCHEDULE on Page PM-5) and (See LUBRICATING THE BOBCAT LOADER on Page PM-32).



Bobcat®

SYSTEM SETUP & ANALYSIS

BICS™ SYSTEM	SA-3
Troubleshooting Guide	SA-3
DELUXE INSTRUMENT PANEL SETUP	SA-9
Deluxe Panel Setup	SA-10
Deluxe Panel Upgrade	SA-9
Passwords (Deluxe)	SA-10
DIAGNOSTICS SERVICE CODES	SA-4
Display	SA-4
Number Codes List	SA-5

**SYSTEM SETUP
& ANALYSIS**







Bobcat®

BICS™ SYSTEM

Troubleshooting Guide

The following list shows the effects which can happen to the loader, and the probable causes when the BICS System lights are off or flashing and associated service code. (See DIAGNOSTICS SERVICE CODES on Page SA-4.)

Indicator Light	Light ON	Light OFF	Effect on Operation of Loader When Light is OFF	SERVICE CODES Means System Error (See Your Bobcat Dealer for Service)		
				No. of Flashes	Service Code	Causes
	PRESS TO OPERATE LOADER Button is pressed.	PRESS TO OPERATE LOADER Button is not pressed.	----	----	----	----
	Seat Bar is down.	Seat Bar is up.	Lift and tilt functions will not operate.	2	11-05	Seat Bar sensor circuit shorted to battery voltage*.
				3	11-06	Seat Bar sensor circuit shorted to ground.
				Continuous Flashing	03-09 03-10	System voltage low System voltage high
	Control valve can be used.	Control valve cannot be used.	Lift, tilt and traction functions will not operate.	1	17-07	Valve output circuit is open.
				2	17-05	Valve output circuit shorted to battery voltage*.
				3	17-06	Valve output circuit shorted to ground.
				3	17-06	Controller not grounded or intermittent ground.
				Continuous Flashing	03-09 03-10	System voltage low System voltage high
	Loader can be moved forward & backward.	Loader cannot be moved forward and backward.	Loader cannot be moved forward and backward.	1	16-07	Traction lock hold solenoid circuit is open.
				2	16-05	Traction lock hold solenoid circuit shorted to battery voltage*.
				3	16-06	Traction lock hold solenoid circuit shorted to ground.
				5	15-02	Traction lock pull solenoid circuit is shorted to battery voltage* - ERROR ON (Should be OFF).
				6	15-03	Traction lock pull solenoid circuit ERROR OFF (Should be ON).
				Continuous Flashing	03-09 03-10	System voltage low System voltage high

* Normal BICS operating voltage is less than electrical system voltage.

DIAGNOSTICS SERVICE CODES

Display

Figure SA-1

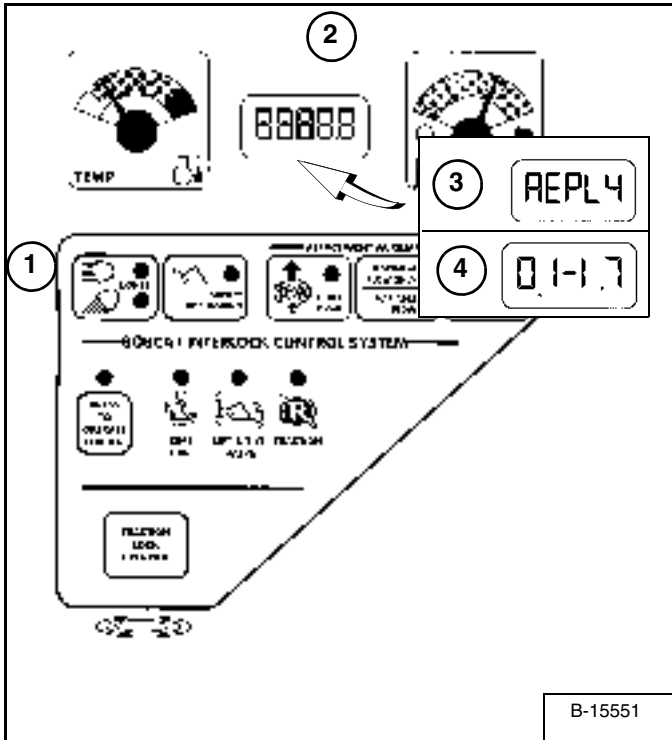

Press and hold the LIGHTS Button (Item 1) [Figure SA-1] for two seconds to view SERVICE CODES in the HOURMETER / CODE DISPLAY (Item 2). If more than one SERVICE CODE is present, the codes will scroll on the HOURMETER / CODE DISPLAY.

NOTE: Corroded or loose grounds can cause multiple service codes and/or abnormal symptoms. All instrument panel lights flashing, alarm sounding, headlights and taillights flashing, could indicate a bad ground. The same symptoms could apply if the voltage is low, such as loose or corroded battery cables. If you observe these symptoms, check grounds and positive leads first.

Service Codes may be either a word (Item 3) [Figure SA-1] or a number (Item 4). (See the following pages for the number codes.)

The following word errors may be displayed.

REPLY One or both instrument panel(s) not communicating with the controller.

INPUT The controller not communicating with the left instrument panel.

CODE The controller is asking for a password. (Deluxe instrument panel only.)

ERROR The wrong password was entered. (Deluxe instrument panel only.)

DIAGNOSTICS SERVICE CODES (CONT'D)

Number Codes List

CODE		CODE	
01-16	Air filter not connected	11-05	Seat bar sensor short to battery
01-17	Air filter plugged	11-06	Seat bar sensor short to ground
02-16	Hydraulic charge filter not connected	12-21	Front auxiliary PWM switch out of range high
02-17	Hydraulic charge filter plugged	12-22	Front auxiliary PWM switch out of range low
		12-23	Front auxiliary PWM switch not in neutral
03-09	Battery voltage low		
03-10	Battery voltage high	13-05	Fuel shut-off hold solenoid short to battery
03-11	Battery voltage extremely high	13-06	Fuel shut-off hold solenoid short to ground
03-14	Battery voltage extremely low	13-07	Fuel shut-off solenoid open circuit
03-22	Battery voltage out of range low		
		14-02	Fuel shut-off pull solenoid error ON
04-09	Engine oil pressure low	14-03	Fuel shut-off pull solenoid error OFF
04-14	Engine oil pressure extremely low		
04-15	Engine oil pressure shutdown level	15-02	Traction lock pull solenoid error ON
04-21	Engine oil pressure out of range high	15-03	Traction lock pull solenoid error OFF
04-22	Engine oil pressure out of range low		
		16-05	Traction lock hold solenoid short to battery
05-09	Hydraulic charge pressure low	16-06	Traction lock hold solenoid short to ground
05-14	Hydraulic charge pressure extremely low	16-07	Traction lock hold solenoid open circuit
05-15	Hydraulic charge pressure shutdown level		
05-21	Hydraulic charge pressure out of range high	17-05	Hydraulic lock valve solenoid short to battery
05-22	Hydraulic charge pressure of range low	17-06	Hydraulic lock valve solenoid short to ground
		17-07	Hydraulic lock valve solenoid open circuit
06-10	Engine speed high		
06-11	Engine speed extremely high	18-05	Spool Lock Solenoid short to battery
06-13	Engine speed no signal	18-06	Spool Lock Solenoid short to ground
06-15	Engine speed shutdown level	18-07	Spool Lock Solenoid open circuit
06-18	Engine speed out of range		
		19-02	Bucket position solenoid error ON
07-10	Hydraulic oil temperature high	19-03	Bucket position solenoid error OFF
07-11	Hydraulic oil temperature extremely high		
07-15	Hydraulic oil temperature shutdown level	20-02	Two-speed solenoid error ON
07-21	Hydraulic oil temperature out of range high	20-03	Two-speed solenoid error OFF
07-22	Hydraulic oil temperature out of range low		
		21-02	Glow plug error ON
08-10	Engine coolant temperature high	21-03	Glow plug error OFF
08-11	Engine coolant temperature extremely high		
08-15	Engine coolant temperature shutdown level	22-02	Starter error ON
08-21	Engine coolant temperature out of range high	22-03	Starter error OFF
08-22	Engine coolant temperature out of range low		
		23-02	Rear base solenoid error ON
09-09	Fuel level low	23-03	Rear base solenoid error OFF
09-21	Fuel level out of range high		
09-22	Fuel level out of range low	24-02	Rear rod solenoid error ON
		24-03	Rear rod solenoid error OFF

DIAGNOSTICS SERVICE CODES (CONT'D)

Number Codes List (Cont'd)

CODE		CODE	
25-02	Rear auxiliary relief solenoid error ON	32-61	Handle lock short to ground
25-03	Rear auxiliary relief solenoid error OFF	32-62	Handle lock short to battery
		32-63	Pedal lock short to ground
26-02	Front base solenoid error ON	32-64	Pedal lock short to battery
26-03	Front base solenoid error OFF	32-65	Sensor supply voltage out of range
		32-66	Battery voltage out of range
27-02	Front rod solenoid error ON	32-67	Switch flipped while operating
27-03	Front rod solenoid error OFF	32-68	Lift handle information error
		32-69	Control pattern switch flipped while operating
28-02	Diverter solenoid error ON	32-70	Right drive handle short to ground
28-03	Diverter solenoid error OFF	32-71	Right drive handle short to battery
29-02	High flow solenoid error ON	33-23	Main Controller (Bobcat Controller) not programmed
29-03	High flow solenoid error OFF		
		34-04	Deluxe panel no communication to Bobcat controller
30-28	Controller Memory failure		
		35-02	Two-speed fan error ON
31-28	Interrupted power failure	35-03	Two-speed fan error OFF
32-04	ACS not communicating with Bobcat Controller	36-48	ACD multiple controllers present
32-23	ACS Not calibrated		
32-31	Tilt actuator fault	37-02	Two-speed secondary error ON
32-32	Tilt actuator wiring fault	37-03	Two-speed secondary error OFF
32-33	Tilt handle wiring fault		
32-34	Tilt actuator not in neutral		
32-35	Tilt handle/pedal not in neutral		
32-36	Lift actuator fault		
32-37	Lift actuator wiring fault		
32-38	Lift handle wiring fault		
32-39	Lift actuator not in neutral		
32-40	Lift handle/pedal not in neutral		
32-41	No communication		
32-49	Lift actuator short to ground		
32-50	Tilt actuator short to ground		
32-51	Lift actuator short to battery		
32-52	Tilt actuator short to battery		
32-53	Lift handle/pedal short to ground		
32-54	Tilt handle/pedal short to ground		
32-55	Lift handle/pedal short to battery		
32-56	Tilt handle/pedal short to battery		
32-57	Lift actuator reduced performance		
32-58	Tilt actuator reduced performance		
32-59	Lift actuator wrong direction		
32-60	Tilt actuator wrong direction		

DIAGNOSTICS SERVICE CODES (CONT'D)

Number Codes List (Cont'd)

CODE		CODE	
38-04	No communication from joystick controller	38-53	Left forward drive solenoid error OFF
38-05	Left joystick X axis not in neutral	38-54	Left reverse drive solenoid error OFF
38-06	Right joystick X axis not in neutral	38-55	Right forward drive solenoid error OFF
38-07	Left joystick Y axis not in neutral	38-56	Right reverse drive solenoid error OFF
38-08	Right joystick Y axis not in neutral	38-57	Front right extend steering solenoid error OFF
38-09	Control pattern switch - Short to Battery or Ground	38-58	Front right retract steering solenoid error OFF
38-11	Lift actuator not in neutral	38-59	Front left extend steering solenoid error OFF
38-12	Tilt actuator not in neutral	38-60	Front left retract steering solenoid error OFF
38-13	Lift actuator fault	38-61	Rear right extend steering solenoid error OFF
38-14	Tilt actuator fault	38-62	Rear right retract steering solenoid error OFF
38-15	Right wheel speed fault	38-63	Rear left extend steering solenoid error OFF
38-16	Left wheel speed fault	38-64	Rear left retract steering solenoid error OFF
38-17	Tilt actuator reduced performance	38-65	Steering pressure solenoid error OFF
38-18	Lift actuator reduced performance	38-66	Back-up alarm error OFF
38-19	Left joystick X axis out of range high	38-67	No communication from Bobcat controller
38-20	Right joystick X axis out of range low	38-68	Wheel angles (alignment) not calibrated
38-21	Left joystick Y axis out of range high	38-69	Lift & tilt actuators not calibrated
38-22	Right joystick Y axis out of range high	38-70	Interrupted power
38-23	Front right steering sensor out of range high	38-71	Battery out of range
38-24	Front left steering sensor out of range high	38-72	Drive pump not calibrated
38-25	Rear right steering sensor out of range high	38-73	Steering mode / drive mode switch flipped while operating
38-26	Rear left steering sensor out of range high	38-74	Uncommanded right wheel speed error ON
38-27	Lift actuator out of range high	38-75	Uncommanded left wheel speed error ON
38-28	Tilt actuator out of range high	38-76	Undercurrent steer pressure solenoid
38-29	Left joystick X axis out of range low	38-77	Undercurrent front right extend steer solenoid
38-30	Right joystick X axis out of range low	38-78	Undercurrent front right retract steer solenoid
38-31	Left joystick Y axis out of range low	38-79	Undercurrent front left extend steer solenoid
38-32	Right joystick Y axis out of range low	38-80	Undercurrent front left retract steer solenoid
38-33	Front right steering sensor out of range low	38-81	Undercurrent rear right extend steer solenoid
38-34	Front left steering sensor out of range low	38-82	Undercurrent rear right retract steer solenoid
38-35	Rear right steering sensor out of range low	38-83	Undercurrent rear left extend steer solenoid
38-36	Rear left steering sensor out of range low	38-84	Undercurrent rear left retract steer solenoid
38-37	5 volt sensor supply 1 out of range low	38-85	5 Volt sensor supply 1 out of range high
38-38	5 volt sensor supply 2 out of range low	38-86	5 Volt sensor supply 2 out of range high
38-39	Lift actuator short to ground / out of range low	38-87	Front right wheel blocked (steering mechanical failure)
38-40	Tilt actuator short to ground / out of range low	38-88	Front left wheel blocked (steering mechanical failure)
38-41	Tilt actuator wrong direction	38-89	Rear right wheel blocked (steering mechanical failure)
38-42	Lift actuator wrong direction	38-90	Rear left steering error
38-43	Left forward drive solenoid error ON	38-91	Right speed sensor missing pulses
38-44	Left reverse drive solenoid error ON	38-92	Left speed sensor missing pulses
38-45	Right forward drive solenoid error ON	38-93	Unresponsive right speed sensor
38-46	Right reverse drive solenoid error ON	38-94	Unresponsive left speed sensor
38-47	Front right steering solenoid error ON	38-98	Controller in drive calibration mode
38-48	Front left steering solenoid error ON	38-99	Controller in wheel position calibration mode.
38-49	Rear right steering solenoid error ON		
38-50	Rear left steering solenoid error ON		
38-51	Steering pressure solenoid error ON		
38-52	Back-up alarm error ON		

DIAGNOSTICS SERVICE CODES (CONT'D)

Number Codes List (Cont'd)

CODE		CODE	
39-04	Left joystick no communication to Bobcat controller	85-02	ACD output 'F' error ON
		85-03	ACD output 'F' error OFF
40-04	Right joystick no communication to Bobcat controller		
		86-02	ACD output 'G' error ON
44-02	Horn error ON	86-03	ACD output 'G' error OFF
44-03	Horn error OFF		
		87-02	ACD output 'H' error ON
45-02	Right blinker error ON	87-03	ACD output 'H' error OFF
45-03	Right blinker error OFF		
		90-02	Service tool output 'C' error ON
46-02	Left blinker error ON	90-03	Service tool output 'C' error OFF
46-03	Left blinker error OFF		
		91-02	Service tool output 'D' error ON
47-21	8 volt sensor supply out of range high	91-03	Service tool output 'D' error OFF
47-22	8 volt sensor supply out of range low		
		92-02	Service tool output 'E' error ON
48-02	Front light relay error ON	92-03	Service tool output 'E' error OFF
48-03	Front light relay error OFF		
		93-02	Service tool output 'F' error ON
49-02	Rear light relay error ON	93-03	Service tool output 'F' error OFF
49-03	Rear light relay error OFF		
60-21	Rear auxiliary control out of range high		
60-22	Rear auxiliary control out of range low		
60-23	Rear auxiliary control not returning to neutral		
64-02	Switched power relay error ON		
64-03	Switched power relay error OFF		
74-72	Bobcat controller in boot code		
74-73	Left hand panel system RX error		
80-02	ACD output 'A' error ON		
80-03	ACD output 'A' error OFF		
81-02	ACD output 'B' error ON		
81-03	ACD output 'B' error OFF		
82-02	ACD output 'C' error ON		
82-03	ACD output 'C' error OFF		
83-02	ACD output 'D' error ON		
83-03	ACD output 'D' error OFF		
84-02	ACD output 'E' error ON		
84-03	ACD output 'E' error OFF		

DELUXE INSTRUMENT PANEL SETUP

Deluxe Panel Upgrade

Icon Identification

Figure SA-2

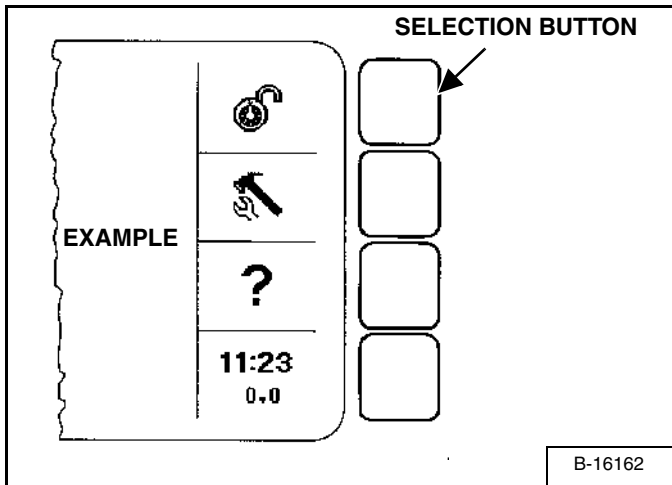

Make selection by pressing SELECTION BUTTON opposite the Icon [Figure SA-2].

ICON	DESCRIPTION
	LOCK/UNLOCK: Allows machine to be locked/unlocked. You must lock machine to activate security system. When system is unlocked, the user can press RUN/ENTER then press START to begin operation. A valid password will need to be entered at startup to run a locked machine.
	TOOL/SETUP: Access system options. Use to set clock, check system warnings, select language, set passwords, etc.
	HELP: Access help on current menu item.
EXIT	EXIT returns you to previous level menu.
11:23 0.0	CLOCK/JOB CLOCK: Press to clear or lock job clock; TOOL/SETUP to set time.
	UP ARROW: Goes backward one screen.
	DOWN ARROW: Goes forward one screen.
	OUTLINE ARROWS: No screen available (backward/forward).
	SELECTION ARROW: Use to select menu item.
NEXT	Goes to the NEXT screen in series. EXAMPLE: the next Active Warning screen.
INFO	Goes to more information about an attachment.
YES/NO	Answer yes/no to current setup question.
CLEAR	Removes previously installed password.
SET	Set accepts current installed password.

DELUXE INSTRUMENT PANEL SETUP (CONT'D)

Deluxe Panel Setup

Display Options

Figure SA-3

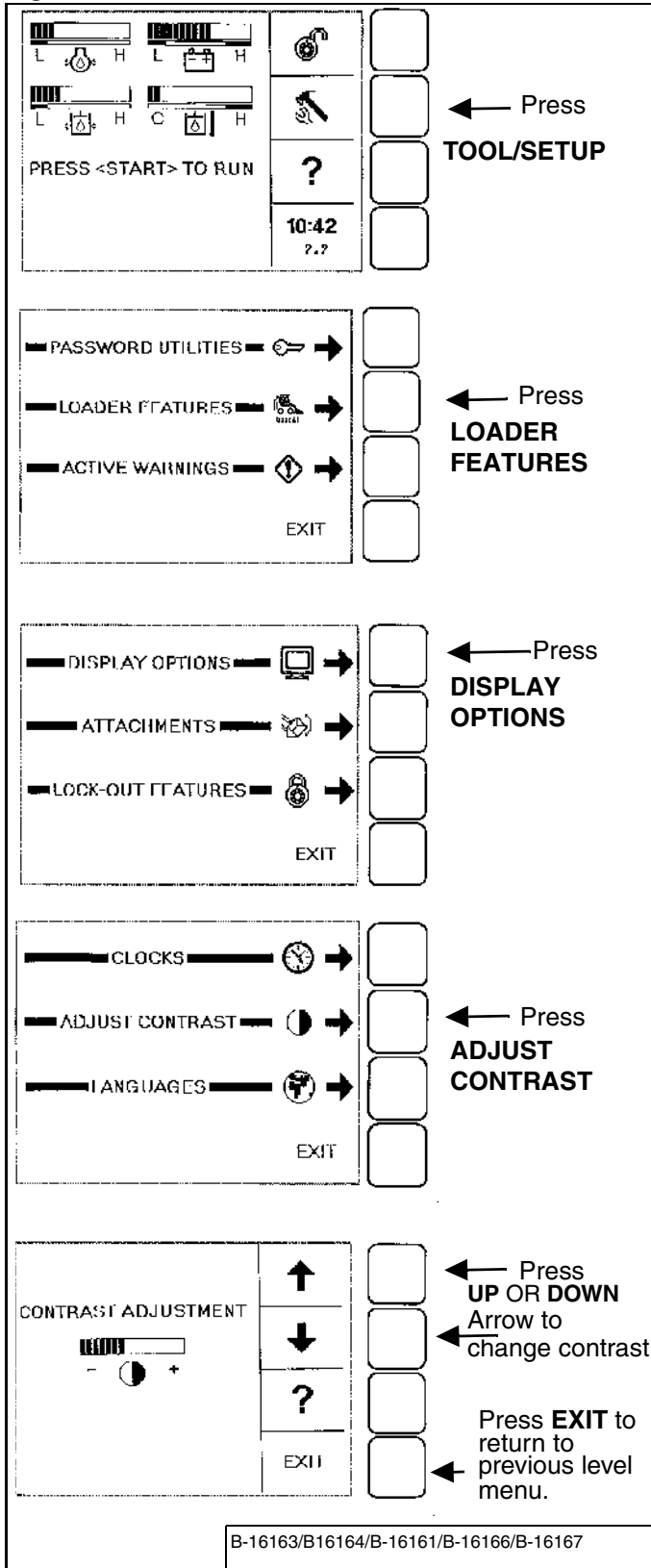

All new machines with Deluxe Instrumentation arrive at Bobcat Dealerships with the panel in locked mode. This means that a password must be used to start the engine [Figure SA-3].

Passwords (Deluxe)

For security purposes, your dealer may change the password and also set it in the locked mode. Your dealer will provide you with the password.

Owner Password:

Allows for full use of the loader and to setup the Deluxe Panel. Owner can select a password to allow starting & operating the loader and modify the setup of the Deluxe Panel. Owner should change the password as soon as possible for security of the loader.

User Password:

Allows starting and operating the loader; cannot change password or any of the other setup features.

DELUXE INSTRUMENT PANEL SETUP (CONT'D)

Passwords (Deluxe) (Cont'd)

Figure SA-4

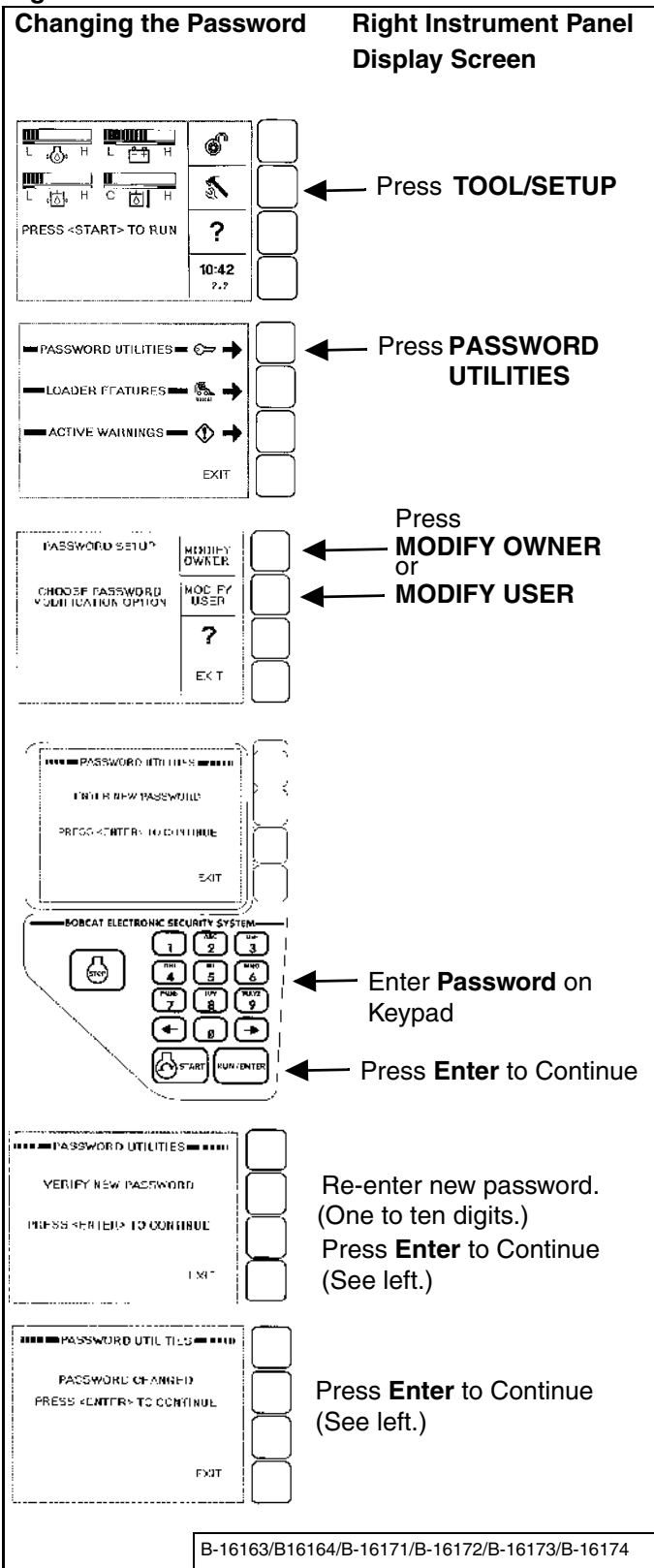

More EXAMPLES:

Clocks

TOOL/SETUP [Figure SA-4]

LOADER FEATURES DISPLAY OPTIONS CLOCKS SET CLOCK

Use the keypad to set time.
Press **RUN/ENTER** to set clock.
Press **EXIT** to return to previous level menu.

RESET JOB CLOCK (Password required)
Press **CLEAR** to reset job clock to zero.
Press **LOCK/UNLOCK** to unlock.
Enter Password and press **RUN/ENTER**.

Languages

TOOL/SETUP LOADER FEATURES DISPLAY OPTIONS LANGUAGES

Select the language, press **RUN/ENTER**.
Press **EXIT** to return to previous level menu.

Vitals (Monitor engine, hydraulic/hydrostatic, electrical functions when engine is running.)

TOOL/SETUP LOADER FEATURES VITALS

Press **SELECTION ARROW** to select METRIC or ENGLISH (M/E) readouts

You can monitor real-time readouts of:

- Engine Oil Pressure
- Engine Coolant Temperature
- Hydraulic Charge Pressure
- Hydraulic Oil Temperature
- System Voltage
- Engine Speed

The Display Panel is easy to use. Continue to set your own preferences for running/monitoring your Bobcat loader.



Bobcat®

SPECIFICATIONS

LOADER SPECIFICATIONS (T250)	SPEC-3
Controls	SPEC-4
Drive System	SPEC-6
Electrical	SPEC-5
Engine	SPEC-5
Environmental	SPEC-7
Fluid Capacities	SPEC-6
Fluid Specifications	SPEC-7
Function Time	SPEC-4
Hydraulic Cylinders	SPEC-5
Hydraulic System	SPEC-5
Instrumentation	SPEC-6
Machine Dimensions	SPEC-3
Machine Rating	SPEC-4
Traction	SPEC-6
Weights	SPEC-4

SPECIFICATIONS



Bobcat®

LOADER SPECIFICATIONS (T250) (CONT'D)

Machine Rating

Lift breakout force	24465 N
Tilt breakout force	24599 N
Ground pressure, 450 mm track	28,27 kPa
Rated operating capacity (ISO 5998)	1200 kg
Push force	27134 N
Tipping load (ISO 8313)	3428 kg

Function Time

Raise lift arms	4,0 s
Lower lift arms	2,3 s
Bucket rollback	1,9 s
Bucket dump	2,5 s

Weights

Operating weight, T250	4186 kg
Operating weight, T250H	4206 kg
Shipping weight	3825 kg

Controls

Engine	Hand lever throttle
Starting	Key-type starter switch and shutdown. Glow plugs automatically activated by Standard or Deluxe instrument panel.
Front auxiliary (standard)	Electrical switch on right-hand steering lever
Rear auxiliary (optional)	Electrical switch on left-hand steering lever
Loader hydraulics tilt and lift	Separate foot pedals or optional Advanced Control System (ACS)
Service brake	Two independent hydrostatic systems controlled by two hand-operated steering levers
Secondary brake	One of the hydrostatic transmissions
Parking brake	Mechanical disc, hand operated rocker-switch on dash panel
Vehicle steering	Direction and speed controlled by two hand levers
Auxiliary pressure release	Pressure is relieved through the coupler block. Push in and hold for 5 s.

LOADER SPECIFICATIONS (T250) (CONT'D)

Engine

Make / Model	Kubota / V3300-DI-T turbo
Fuel	Diesel
Cooling	Liquid
Power at 2400 RPM	58 kW
Rated speed (EEC 80/1269, ISO 9249)	2400 RPM
Torque at 1400 RPM (ISO 9249)	287 Nm
Number of cylinders	4
Displacement	3,3 l
Bore	98 mm
Stroke	110 mm
Fuel consumption	11,6 l/h (Estimated fuel consumption is based on testing by Bobcat Company in high duty-cycle digging applications.)
Lubrication	Pressure system with filter
Crankcase ventilation	Open
Air filter	Dry replaceable cartridge with safety element
Ignition	Diesel-compression
Starting aid	Intake air heater

Electrical

Alternator	Belt driven – 90 A – open
Battery	12 V – 1000 cold cranking A at -18°C – 180 min reserve capacity
Starter	12 V – gear reduction type – 3.0 kW

Hydraulic System

Pump type	Engine driven, gear type
Pump capacity at high idle – T250	80,3 l/min
Pump capacity at high idle – T250H	151,4 l/min
System relief at Quick Couplers	227,5 bar
Control valve	Three-spool, open-centre type with float detent on lift and electrically controlled auxiliary spool
Hydraulic filter	Full-flow replaceable – 3 µm synthetic media element
Fluid lines	SAE standard tubelines, hoses, and fittings

Hydraulic Cylinders

Lift cylinder (2)	Double-acting
Lift cylinder bore	63,5 mm
Lift cylinder rod	44,5 mm
Lift cylinder stroke	825,0 mm
Tilt cylinder (2)	Double-acting with cushioning feature on dump
Tilt cylinder bore	76,2 mm
Tilt cylinder rod	38,1 mm
Tilt cylinder stroke	383,5 mm

LOADER SPECIFICATIONS (T250) (CONT'D)

Drive System

Transmission	Infinitely variable tandem hydrostatic piston pumps, driving two fully reversing hydrostatic motors
Tracks	450 mm width. Tension-grease cylinder and triple-flange spring rollers
Main drive	Fully hydrostatic, rubber track drive

Traction

Tracks	450 mm wide, rubber
Travel speed	10,1 km/h

Instrumentation

The following loader functions are monitored by a combination of gauges and warning lights in the operator's line of sight. The system alerts the operator of monitored loader malfunctions by way of audible alarm and visual warning lights.

Standard Instrument Panel

- Gauges
 - Engine coolant temperature
 - Fuel
 - Hour-meter
- Indicators
 - Attachment Control Device
 - BICS functions
 - Intake air heater
- Warning lights
- Advanced Control System (ACS)
- Engine air filter
- Engine coolant temperature
- Engine oil pressure
- Fuel level
- General warning
- Hydraulic filter
- Hydraulic oil temperature
- Hydrostatic charge temperature
- Seat belt
- System voltage

Deluxe Instrument Panel (Option)

Same gauges, warning lights and other features as Standard Instrument Panel, plus:

- Bar-type gauges
 - Engine oil pressure
 - System voltage
 - Hydrostatic charge pressure
 - Hydraulic oil temperature
- Additional features
 - Keyless start with password capability
 - Digital clock
 - Job clock
 - Attachments information
 - Digital tachometer
 - High flow lockouts
 - Multi-language display
 - Help screens
 - Diagnostic capability
 - Engine/hydraulic systems shutdown function

Fluid Capacities

Cooling system capacity	16,3 l
Engine oil with filter capacity	13,2 l
Fuel tank capacity	113,6 l
Hydraulic reservoir capacity	17,8 l
Hydraulic / Hydrostatic system capacity	49,2 l
Rollers and idlers capacity	0,1 l

LOADER SPECIFICATIONS (T250) (CONT'D)

Fluid Specifications

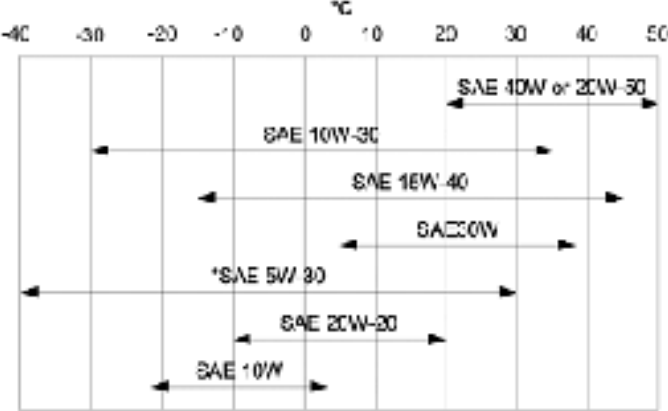
Engine coolant	Polypropylene glycol/water mix (53% – 47%) with freeze protection to -37°C
Engine oil	<p>Oil must meet API Service Classification of CD, CE, CF4, CG4, or better. Recommended SAE viscosity number for anticipated temperature range.</p>  <p>* Can be used only when available with appropriate diesel rating. For synthetic oil use the recommendation from the oil manufacturer.</p>
Hydraulic fluid	Bobcat Fluid (P/N 6563328). If fluid is not available use 10W-30/10W Class SE motor oil for temperatures above -18°C or 5W-30 Class SE motor oil for temperatures below -18°C.

Environmental

Noise level L_{pA} (EU Directive 2000/14/EC)	85 dB(A)
Noise level L_{WA} (EU Directive 2000/14/EC)	107 dB(A)
Whole body vibration (ISO 2631-1)	1,62 ms^{-2}
Hand-arm vibration (ISO 5349-1)	5,10 ms^{-2}



Bobcat®

WARRANTY

BOBCAT LOADERS

Ingersoll Rand International (IRI) warrants to its authorised dealers who in turn warrant to the end-user/owner that each new Bobcat loader will be free from proven defects in material and workmanship for twelve months from the date of delivery to the end-user/owner or 2000 hours of machine usage, whichever occurs first.

During the warranty period, the authorised Bobcat dealer shall repair or replace, at its option, without charge for parts, labour and travel time of mechanics, any part of the Bobcat product which fails because of defects in material or workmanship. The end-user/owner shall provide the authorised Bobcat dealer with prompt written notice of the defect and allow reasonable time for replacement or repair. Ingersoll Rand International may, at its option, request failed parts to be returned to the factory. Transportation of the Bobcat product to the authorized Bobcat dealer for warranty work is the responsibility of the end-user/owner.

The warranty does not apply to tyres or other trade accessories not manufactured by Ingersoll Rand. The owner shall rely solely on the warranty, if any, of the respective manufacturers thereof. The warranty does not cover replacement of scheduled service items such as oil, filters, tune-up parts, and other high-wear items. The warranty does not cover damages resulting from abuse, accidents, alterations, use of the Bobcat product with any bucket or attachment not approved by Ingersoll Rand, air flow obstructions, or failure to maintain or use the Bobcat product according to the instructions applicable to it.

IRI EXCLUDES OTHER CONDITIONS, WARRANTIES OR REPRESENTATIONS OF ALL KINDS, EXPRESSED OR IMPLIED, STATUTORY OR OTHERWISE (EXCEPT THAT OF TITLE) INCLUDING ALL IMPLIED WARRANTIES AND CONDITIONS RELATING TO MERCHANTABILITY, SATISFACTORY QUALITY AND FITNESS FOR A PARTICULAR PURPOSE.

CORRECTIONS BY IRI OF NONCONFORMITIES WHETHER PATENT OR LATENT, IN THE MANNER AND FOR THE TIME PERIOD PROVIDED ABOVE, SHALL CONSTITUTE FULFILMENT OF ALL LIABILITIES OF IRI FOR SUCH NONCONFORMITIES, WHETHER BASED ON CONTRACT, WARRANTY, TORT, NEGLIGENCE, INDEMNITY, STRICT LIABILITY OR OTHERWISE WITH RESPECT TO OR ARISING OUT OF SUCH PRODUCT.

THE REMEDIES OF THE END-USER/OWNER SET FORTH UNDER THE PROVISIONS OF THE WARRANTY OUTLINED ABOVE ARE EXCLUSIVE AND THE TOTAL LIABILITY OF IRI INCLUDING ANY HOLDING, SUBSIDIARY, ASSOCIATED OR AFFILIATED COMPANY OR DISTRIBUTOR WITH RESPECT TO THIS SALE OR THE PRODUCT AND SERVICE FURNISHED HEREUNDER IN CONNECTION WITH THE PERFORMANCE OR BREACH THEREOF, OR FROM DELIVERY, INSTALLATION, REPAIR OR TECHNICAL DIRECTION COVERED BY OR FURNISHED UNDER THIS SALE, WHETHER BASED ON CONTRACT, WARRANTY, TORT, NEGLIGENCE, INDEMNITY, STRICT LIABILITY OR OTHERWISE SHALL NOT EXCEED THE PURCHASE PRICE OF THE PRODUCT UPON WHICH SUCH LIABILITY IS BASED.

IRI INCLUDING ANY HOLDING, SUBSIDIARY, ASSOCIATED OR AFFILIATED COMPANY AND DISTRIBUTOR SHALL IN NO EVENT BE LIABLE TO THE END-USER/OWNER, ANY SUCCESSORS IN INTEREST OR ANY BENEFICIARY OR ASSIGNEE RELATING TO THIS SALE FOR ANY CONSEQUENTIAL, INCIDENTAL, INDIRECT, SPECIAL OR PUNITIVE DAMAGES ARISING OUT OF THIS SALE OR BY ANY BREACH THEREOF, OR ANY DEFECT IN, OR FAILURE OF, OR MALFUNCTION OF THE PRODUCT UNDER THIS SALE, WHETHER BASED UPON LOSS OF USE, LOST PROFITS OR REVENUE, INTEREST, LOST GOODWILL, WORK STOPPAGE, IMPAIRMENT OF OTHER GOODS, LOSS BY REASON OF SHUTDOWN OR NON-OPERATION, INCREASED EXPENSES OF OPERATION OR CLAIMS OF USER OR CUSTOMERS OF THE USER FOR SERVICE INTERRUPTION WHETHER OR NOT SUCH LOSS OR DAMAGE IS BASED ON CONTRACT, WARRANTY, TORT, NEGLIGENCE, INDEMNITY, STRICT LIABILITY OR OTHERWISE.

