

>> Reservedelsliste C 100C42.2-52

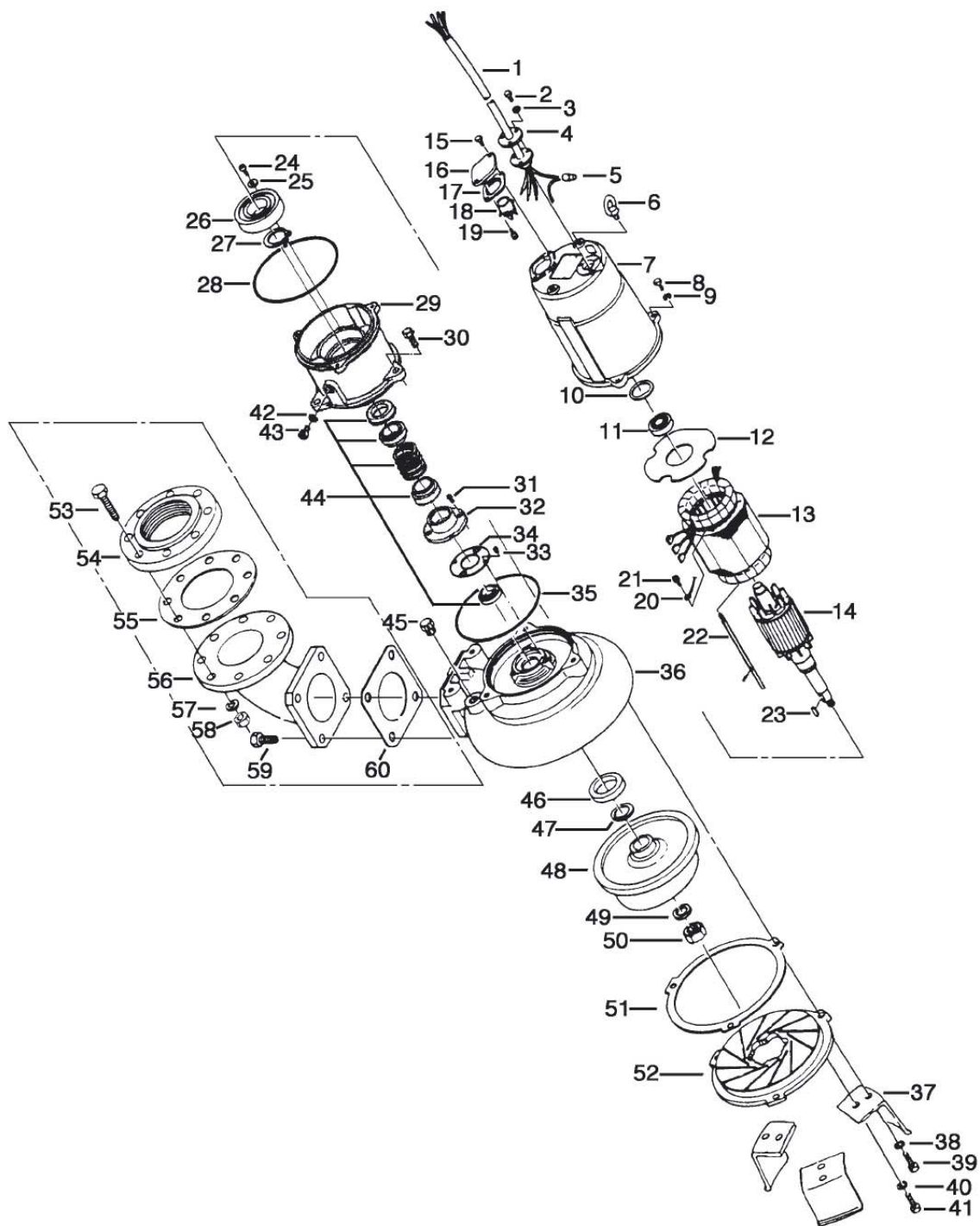

>> Se listen på bagsiden!

STARING

Staring Maskinfabrik A/S
Starengvej 9-11
DK-9700 Brønderslev

Tlf.: +45 9882 1622
Fax: +45 9882 5591
www.staring.dk
staring@staring.dk

CVR.nr. DK 2767 2701

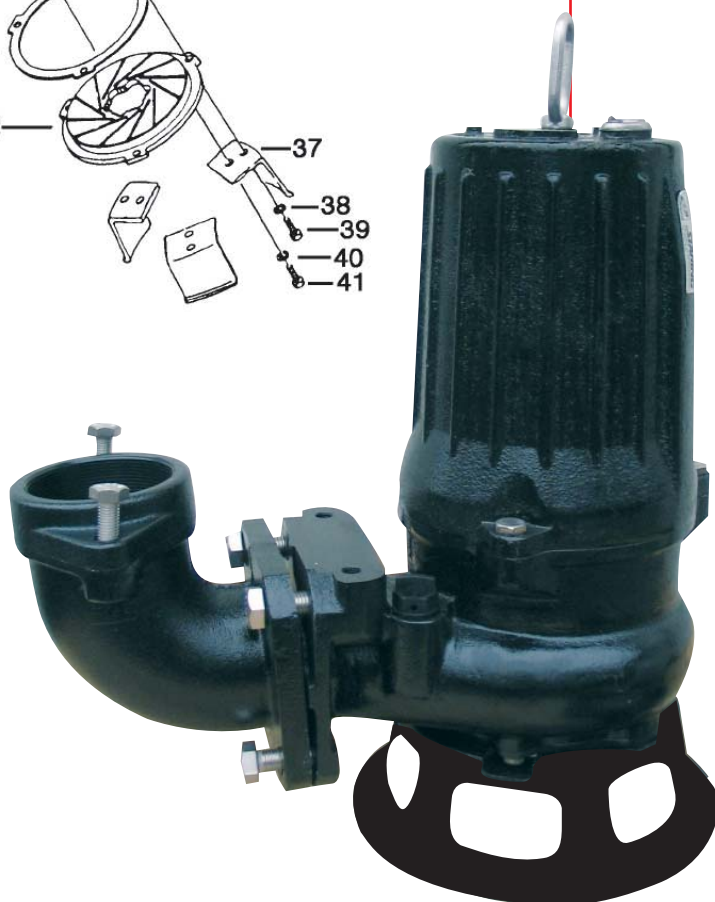

>> Reservedelsliste C 100C42.2-52

ITEM	CODE No.	DESCRIPTION	Q'TY	SIZE	MATERIAL	WEIGHT kg	REMARKS
1	001-484-18	Cabtyre Cable Set (10m)380/400/415V-	1	H07RN4Cx1.5mm2(CEE)	BE(HAR)		
2	140-021-17	Hex.Bolt	3	M5x20	SUS304	0.001	
3	142-422-18	Seal Washer	3	PM-5	SUS+NBR		
4	003-111-20	Gland	1		SUS304		
5	009-146-19	Terminal	4	CE-5	CU	0.002	
6	072-100-20	Eye Bolt	2	M10	SUS304	0.07	
7	064-509-15	Motor Frame	1		FC	7.5	
8	140-055-10	Hex.Bolt	3	M8x25	SUS304	0.014	
9	142-163-18	Spring Washer	3	M8	SUS304	0.001	
10	142-196-10	Wave Washer	1	#6205/6304	SK-5	0.001	
11	052-188-17	Bearing	1	AC-6304ZZC3		0.15	
12	058-117-13	Lead Wire Protection Plate	1	d70xd140x1.6l	Resin	0.02	
13	056-002-45	Stator 380/400/415V-50Hz(EUR)	1set				
14	055-608-17	Rotor	1set			7	
15	140-053-18	Hex.Bolt	2	M8x18	SUS304		
16	127-195-12	Protector Fixing Plate	1	22/37-BE2 Type	SUS304	0.04	
17	121-446-13	Packing	1	22/37-BE2 Type	NBR	0.01	*
18	053-254-18	Motor Protector 380/400/415V-50Hz(EU)	1	KA313-GCXL103	(H.C)	0.022	
19	143-087-23	Pan Screw (w/Spring)	2	M4x10	SWRM		
20	141-004-59	Hex.Nut	1	M6	SWRM		
21	009-159-15	Terminal	1	R-2-6	CU	0.001	
22	129-003-18	Stopper	1	M6x160(11/20)	SS		
23	147-066-15	Impeller Key	1	10x8x22l	SUS	0.013	
24	143-042-13	Pan Screw	3	M6x10	SWRM	0.001	
25	062-196-19	Bearing Fixing Washer	3	d8xd20.5x2.3l	SS	0.005	
26	052-112-10	Bearing	1	6309ZZC3		0.85	
27	146-027-11	Retaining Ring	1	C45	SK-5	0.01	
28	122-333-19	O-Ring	1	170xd3.1	NBR	0.001	*
29	060-373-16	Bearing Housing	1		FC	5	
30	140-098-15	Hex.Bolt	3	M12x35	SUS304	0.045	
31	143-070-23	Pan Screw	2	M5x6	SWRM	0.001	
32	030-156-18	Oil Lifter	1	H-35(A)(T)	Resin	0.053	
33	143-070-10	Pan Screw	3	M5x6	SWRM	0.001	
34	030-150-12	Seal Stopper	1	H-35(A)(T)	SPCC	0.073	
35	122-246-14	O-Ring	1	180xd3.1	NBR	0.001	*
36	020-526-12	Pump Casing	1	22-BE2/CE2 Type	FC	14.5	
37	023-469-15	Pump Stand	3	22/37-BE3 Type	SPHC	0.64	
38	142-165-10	Spring Washer	3	M12	SUS304	0.001	
39	140-098-15	Hex.Bolt	3	M12x35	SUS304	0.045	
40	142-163-18	Spring Washer	3	M8	SUS304	0.001	
41	140-054-19	Hex.Bolt	3	M8x20	SUS304	0.013	
42	121-247-12	Packing	1	d12.3xd18x2l	PE	0.001	*
43	035-113-18	Oil Plug	1	M12x14	SUS304	0.003	
44	025-280-16	Mechanical Seal	1	H-35A	SiC+CCBN	0.19	Oil ISO VG32 (1250ml)
45	046-107-13	Air Release Valve	1	PT- 1/2"	Nylon	0.017	
46	026-111-18	Oil Seal	1	TC-456812	NBR	0.04	
47	040-107-28	Impeller Shim		d25.2xd38x0.3l	SUS304	0.002	
48	021-L81-13	Impeller (50Hz)	1	100C42.2-52	FC	5.2	
48	021-L82-14	Impeller (60Hz)	1	100C42.2-62	FC	4.9	
49	142-170-18	Spring Washer	1	M24	SUS304	0.032	
50	141-011-17	Hex.Nut	1	M24	SUS304	0.095	
51	120-104-13	Packing		d230.5xd258x0.3l	M-Sheet	0.005	
52	022-738-15	Suction Cover	1	22/37-CE3	FCD	4.8	
53	140-130-36	Hex.Bolt	8	M16x70	SWRM	0.135	
54	048-109-11	Screwed Flange	1	JIS10Kx100mm	FC	4	
55	121-106-34	Packing	1	JIS10Kx100mm	NR	0.11	
56	037-170-19	Discharge Bend	1	80x100mm	FC	8.5	
57	142-166-37	Spring Washer	8	M16	SWRH	0.01	
58	141-008-11	Hex.Nut	8	M16	SUS304	0.03	
59	140-124-11	Hex.Bolt	4	M16x40	SUS304	0.09	
60	121-152-19	Packing	1	145mm2(P.C.145)	NBR	0.04	*
		<Packing O-Ring Set>					
	173-444-12	Packing O-Ring Set	1set	(*)		0.06	