



Betjeningsvejledning

metabo[®]
work. don't play.



Sr 355
Sr 356
Sr E 357
Sr 358
Sr E 359



3 års garanti på alle Metabo maskiner

Gælder kun ved registrering af dit køb på: www.metabo.dk



P1 = 350 W
P2 = 190 W

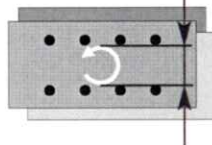

2,5 mm
(3/32")



Sr 355 2,5 kg (5,5 lbs)
Sr 356 2,5 kg (5,5 lbs)
Sr E 357 2,6 kg (5,7 lbs)
Sr 358 2,7 kg (6,0 lbs)
Sr E 359 2,8 kg (6,2 lbs)

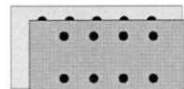

Sr 355, Sr 356, Sr E 357
93 x 230 mm (3 21/32" x 9 1/16")
Sr 358, Sr E 359
115 x 280 mm (4 17/32" x 11 1/32")



12000 -
22000 min⁻¹ (rpm)
(Sr E 357/359)



15000 min⁻¹ (rpm)
(Sr E 357/359)



22000 min⁻¹ (rpm)
(Sr 355/356/358)



15000 min⁻¹ (rpm)
(Sr 355/356/358)

Metabowerke GmbH
Postfach 1229
D - 72602 Nürtingen



J. Kusserow

Jürgen Kusserow
Geschäftsleitung

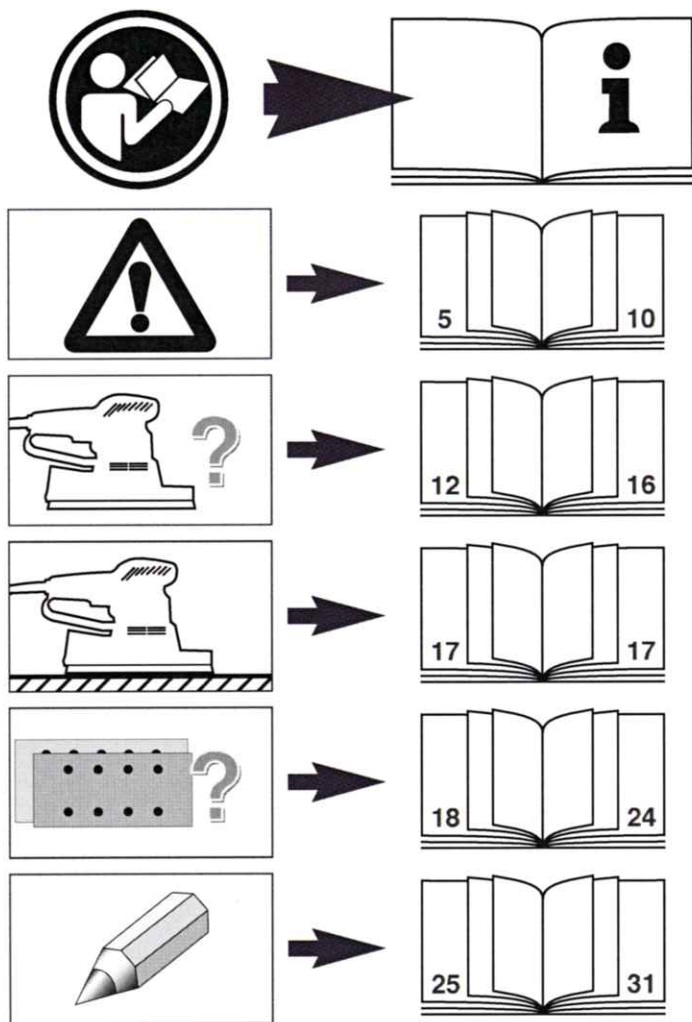

Giv agt!

Læs først brugsanvisning ordentligt igennem !
 Kun derved er De i stand til at lære maskinen og dennes brug at kende,
 og derved undgå fejlbetjening og farlige situationer.



Korrekt anvendelse: Sr 355-359 rystepudserne er kun egnet til torslibning af lige og hvælvede flader, træ, kunststof, jernfri legeringer, stålplader o.lign. samt spartlede og lakerede flader. Brugeren hæfter alene for skader, opstået som følge af ikke tilsigtet anvendelse. Generelle sikkerhedsbestemmelser og vedlagte sikkerhedsanvisninger skal overholdes.



Reparation af el-værktøj må kun foretages af fagfolk !

Metabo-elværktøjer, der skal repareres, kan indsendes til en af de adresser, der står på reservedelslisten. Beskriv venligst den konstaterede fejl ved indsendelsen.



CE Overensstemmelseserklæring. Vi erklærer på eget ansvar, at dette produkt er i overensstemmelse med følgende standarder: EN 50144 i henhold til bestemmelserne i direktiverne 73/23/EOF, 98/37/EG.



Støjemission og vibration

Værktøjet A -vægtede lydtrykniveau er typisk 80 dB (A). Under arbejde med værktøjet kan lydniveauet overstige 85 dB (A). Brug høreværn !
Det vægtede accelerationsniveau 4 m/s².

Sr 355, Sr 356, Sr 357



Støjemission og vibration

Værktøjet A -vægtede lydtrykniveau er typisk 80 dB (A). Under arbejde med værktøjet kan lydniveauet overstige 85 dB (A). Brug høreværn !
Det vægtede accelerationsniveau 7 m/s².

Sr E 358, Sr E 359



A: Ikke beregnet til vådslibning !
B: Udsugningsanordningen skal benyttes !



Under arbejdet opstår der støv, der ofte kan være sundhedsskadeligt (fx ved bearbejdning af ege- og bøgetræ, stenmaterialer, maling, som kan indeholde bly eller andre skadelige stoffer) og ikke må komme ind i den menneskelige organisme.

Derfor bør der anvendes støvudsugning, og brugeren bør desuden bruge åndedrætsværn.

Støv, der har lagt sig, bør fjernes omhyggeligt, fx kan det fjernes med en egnet specialstøv suger.



Betjening af maskinen (A-C)

A: Skydekontakt på stilling »fra«

B: Skydekontakt på stilling »til«

C: Regulator for forvalg af svingtal

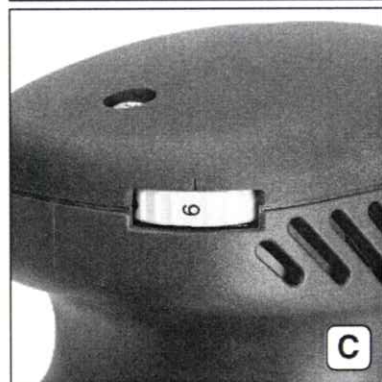
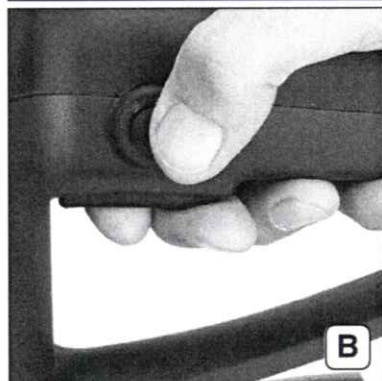
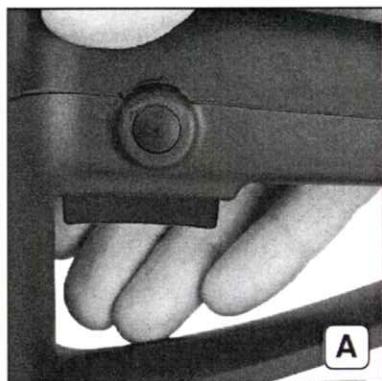



	$\frac{x}{\text{min}^{-1}}$
1	12000
2	14000
3	16000
4	18000
5	20000
6	22000

A

A: Elektronisk indstilling af svingtal
B: Anbefalede svingtal for forskellige materialer 1-2:
Kunststof 1-2: Metaller/gammel maling, 5-6: Trægrov-
/finslibning

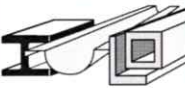
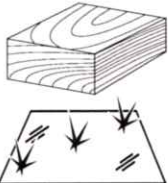
1-2	 PE, PP, PVC...
3-4	 Fe, Cu, Al... Plexi...
5-6	

B

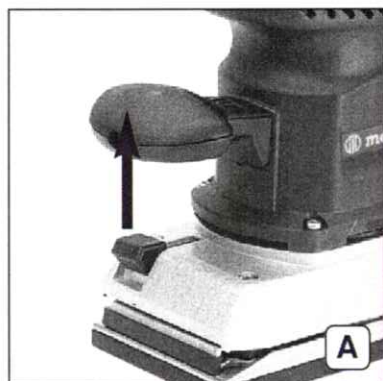

Montering af slibeark

A: Loft klemmegrebet

B: Læg slibearket i og spænd det fast med grebet

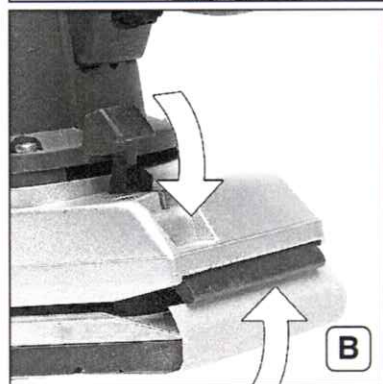

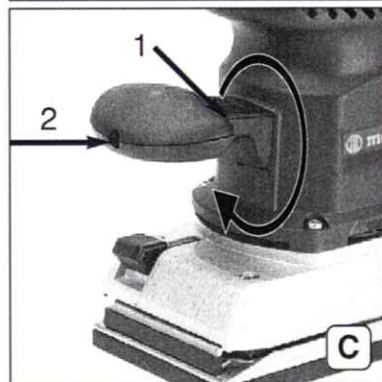
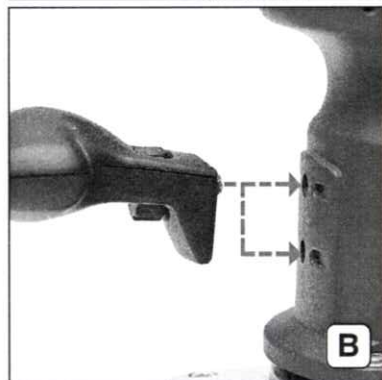

Montering af det ekstra håndtag:

A+B: Der er to muligheder for det ekstra håndtag

C: Sæt det ekstra håndtag på maskinen, som vist, og spænd det fast med den integrede skrue (1), brug evt. en skruetrækker (2)

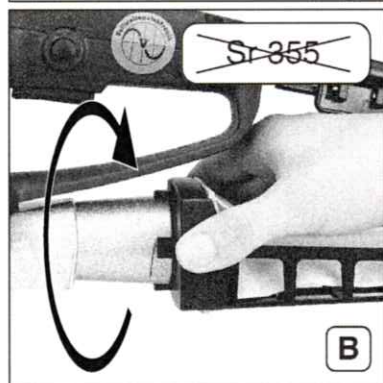
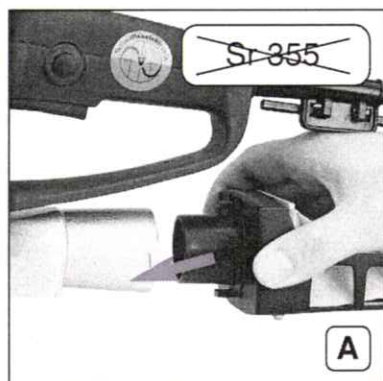

A-B: Til støvudsugning - anbring koblingsstykket til støvposen som vist (se pilen!) og drej den fast.

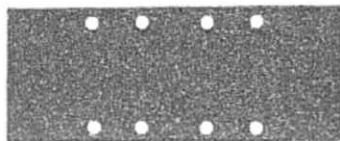

24 826	(P 40)
24 827	(P 60)
24 828	(P 80)
24 829	(P 100)
24 830	(P 120)
24 831	(P 180)
24 832	(P 240)
24 833	(2 x P 40 2 x P 80 2 x P 120 2 x P 180 2 x P 240)

A

Tilbehør til slibning og polering (A-Q)
Slibeark 93 x 230 mm til tørslibning,
Pakninger med 10 stk.

A: Med huller, kvalitet Finishing

B: Med huller, kvalitet Ekstra

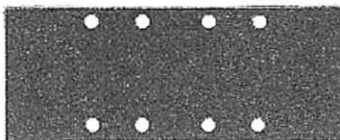

24 480	(P 40)
24 481	(P 60)
24 482	(P 80)
24 483	(P 100)
24 484	(P 120)
24 485	(P 180)
24 486	(P 240)
24 490	(2 x P 40 2 x P 80 2 x P 120 2 x P 180 2 x P 240)

B



24 808	(P 40)
24 809	(P 60)
24 810	(P 80)
24 811	(P 100)
24 812	(P 120)
24 813	(P 180)
24 814	(P 240)
24 815	(2 x P 40 2 x P 80 2 x P 120 2 x P 180 2 x P 240)

C

Slibeark 93 x 230 mm til torslibning,
Pakninger med 10 stk.

C: Uden huller kvalitet Finishing

D: Uden huller kvalitet Ekstra

E: Hulstanser til uhullede slibeark

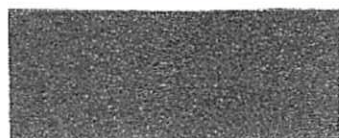

24 328	(P 40)
24 329	(P 60)
24 330	(P 80)
24 331	(P 100)
24 332	(P 120)
24 333	(P 180)
24 334	(P 240)
24 824	(2 x P 40 2 x P 80 2 x P 120 2 x P 180 2 x P 240)

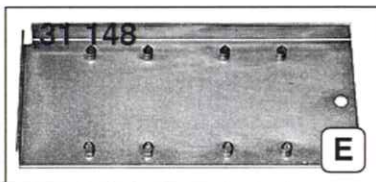
D**E**

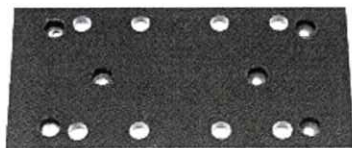

24 736

K

K: Hullet burre-pudsesål 92 x 185 mm

L: Hullede burre-slibebark 93 x 185 til torslibning,
pakninger med 5 stk.

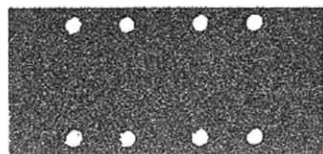

24 730 (P 40)
24 731 (P 60)
24 732 (P 80)
24 733 (P 100)
24 734 (P 120)
24 735 (P 240)

L

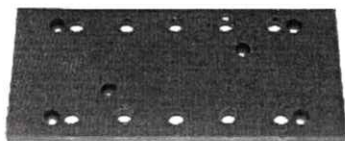

24 749

M

M: Hullet burre-pudsesål 112 x 230 mm
N: Hullede burre-slibebark 115 x 230 til torslibning,
pakninger med 5 stk.



24 750 (P 40)
24 751 (P 60)
24 752 (P 80)
24 753 (P 100)
24 754 (P 120)
24 755 (P 240)

N

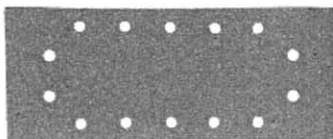

24 800	(P 40)
24 801	(P 60)
24 802	(P 80)
24 803	(P 100)
24 804	(P 120)
24 805	(P 180)
24 806	(P 240)
24 807	(2 x P 40 2 x P 80 2 x P 120 2 x P 180 2 x P 240)

F

Slibebark 115 x 280 mm til tørslibning,
Pakninger med 10 stk.

F: Med huller, kvalitet Finishing

G: Med huller, kvalitet Ekstra

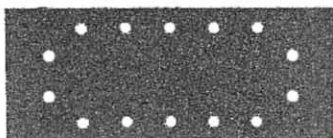

24 491	(P 40)
24 492	(P 60)
24 493	(P 80)
24 494	(P 100)
24 495	(P 120)
24 496	(P 180)
24 497	(P 240)
24 499	(2 x P 40 2 x P 80 2 x P 120 2 x P 180 2 x P 240)

G



24 816 (P 40)
24 817 (P 60)
24 818 (P 80)
24 819 (P 100)
24 820 (P 120)
24 821 (P 180)
24 822 (P 240)
24 823 (2 x P 40
2 x P 80
2 x P 120
2 x P 180
2 x P 240)

H

Slibebark 115 x 280 mm til tørslibning,
Pakninger med 10 stk.

H: Uden huller kvalitet Finishing

I: Uden huller kvalitet Ekstra

J: Hulstanser til uhullede slibebark



24 365 (P 40)
24 366 (P 60)
24 367 (P 80)
24 368 (P 100)
24 369 (P 120)
24 370 (P 180)
24 371 (P 240)
24 825 (2 x P 40
2 x P 80
2 x P 120
2 x P 180
2 x P 240)

I



J



~~Sr 355~~



O

O: 31 289 Koblingsstykke til støvpose
P: 31 288 Papirpose (5 stk.)
Q: 31 758 Støvpose

~~Sr 355~~



P

~~Sr 355~~



Q