



# 2200D

Utility Vehicle



# Specifications

Machine Rating	2200D
Maximum bed load	476 kg
Max. travel speed - forward	40 km/h
Max. travel speed - reverse	24.4 km/h

Engine	
Make / Model	Kubota D722
Fuel / Cooling	Diesel / Liquid
Power (EEC 97/68/EC)	14.9 kW
Maximum torque at 2600 RPM (EEC 97/68/EC)	46.2 Nm
Number of cylinders	3
Displacement	0.7 l
Fuel tank capacity	24.6 l

Weights	
Operating weight	835 kg

Controls	
Vehicle steering	Self adjusting rack and pinion, tilt adjustable steering wheel
Travel speed	Foot pedal. Forward/reverse travel direction is selected by a transmission lever on the dashboard.

Drive System	
Transmission	Torque converter with 6:1 ratio

Standard Features	
Front lights with dashboard-mounted on/off switch	
Full-time, IntelliTrak® four-wheel drive	
Electrically controlled cargo box	
Instrumentation	
Parking brake	
Tilting steering wheel	
Rear coupling device	
Front recovery hitch	
Road lights	
Backup alarm	
Retractable seat belt	
Tyres — All-terrain 23 x 8-12 (front), 23 x 10.5-12 (rear), tubeless, 4-ply rating	
Full suspension driver's seat with fore/aft adjustment	
Four-point Roll Over Protective Structure (ROPS)	
Power connection for lighting and light-signaling devices on trailer	
Heavy duty suspension	
Horn	
European homologation	
Warranty: 24 months or 2000 hours	

Options	
Sealed Continuous Variable Transmission (CVT) cover	
Bed mat	
Brake calliper rock guard	
Mossy Oak® Forest Floor® bed and body camouflage kit	



## Dimensions

All dimensions in mm.

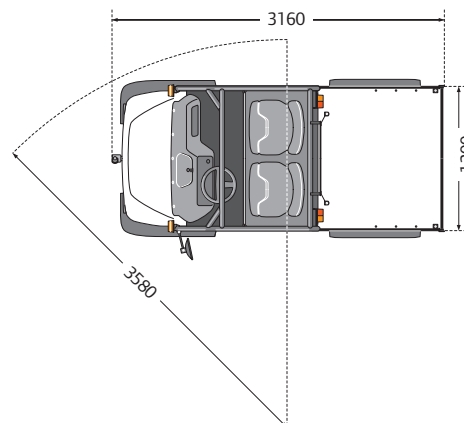
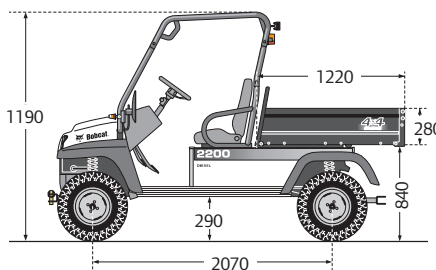
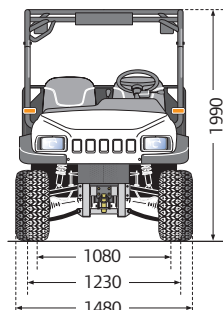

**Bobcat Europe**

Drève Richelle 167  
B-1410 Waterloo, Belgium  
www.bobcat.com

Specifications and design are subject to change without notice.