

Compact and responsive :

- Working height : 7.75 m
- Platform height : 5.75 m
- Load capacity : 230 kg including 2 people
- Width : 0.81 m
- Inside use



78 XE

 **Load capacity**.....230 kg including 2 people
Capacity on extension :
110 kg including 1 person

 **Working height**7.75 m
Platform floor height5.75 m

 **Overall length**1.89 m
Overall width0.81 m
Overall height2.11 m
Height with rails folded1.93 m
Platform size1.67 x 0.78 m
Platform extension size0.90 m
Ground clearance7.60 cm
Turning radius
 Inside0.05 m
 Outside1.7 m

 **Travel speed**.....0 to 4 Km/h
Lift/lower speed14 s/20 s
Inside usewind speed 0 Km/h

 **Batteries**24 V/220 Ah
 Integrated charger24 V/30 A

 **Gradeability**25%
Maximum slope2°

 **Tyres (Solid non-marking)**14.5"x4"
 2 wheel drive - 2 wheel steer

 **Weight**1380 kg

Standard equipment

- Single beam lifting system with self lubricating pins
- Proportional controls
- Electronic controller for increased battery duty cycle
- Pot-hole Safety system
- Removable control box
- Battery charge indicator
- Swing gate for easy access to platform
- Foldable guardrail (below 2 m) for increased accessibility through standard doors
- Hour meter
- 220 V predisposal
- Flashing beacon
- Lifting brackets
- Forklift pockets

Options

- All motion alarm
- Working lights
- 220 V electric plug in platform
- Airline to the platform

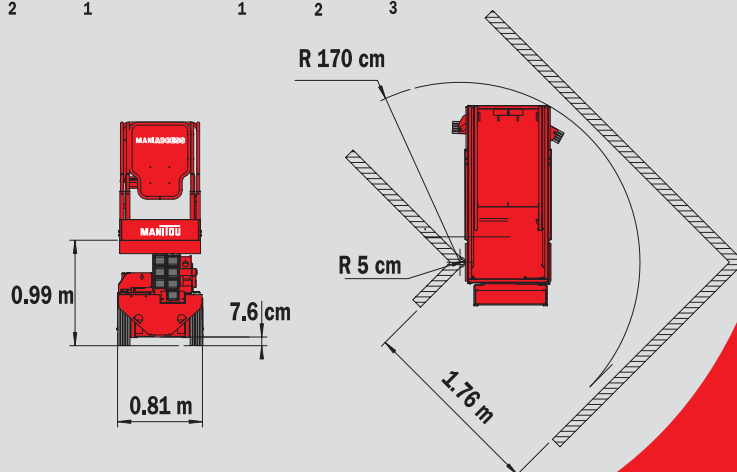
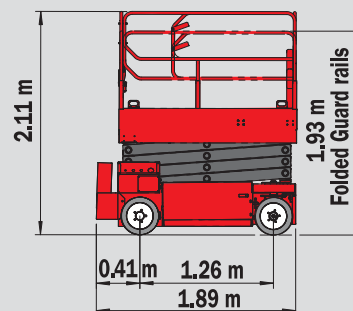
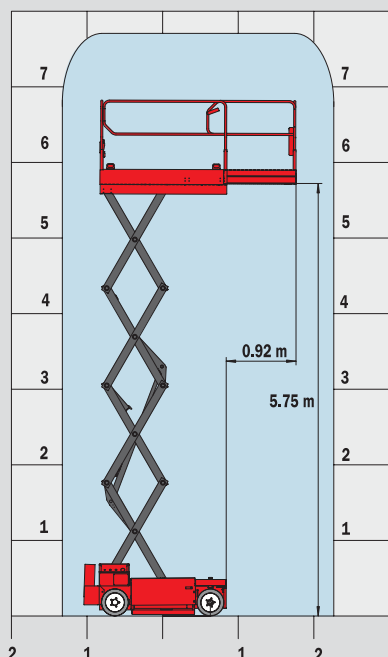

This publication in no way constitutes an offer and the company reserves the right to alter specification without prior notice. The MANITOU models presented in this brochure can be supplied complete with optional equipment attachments.

