

MANISCOPIC

MRT 1850

M Series



- Lift height : 17.90 m
- Max. reach : 15.20 m
- Engine : 123 HP - 91 kw
- 4 wheel drive - 4 wheel steer
- Hydrostatic transmission
- Levelling system



ROTATION ON STABILISERS FULLY EXTENDED WITH FORKS

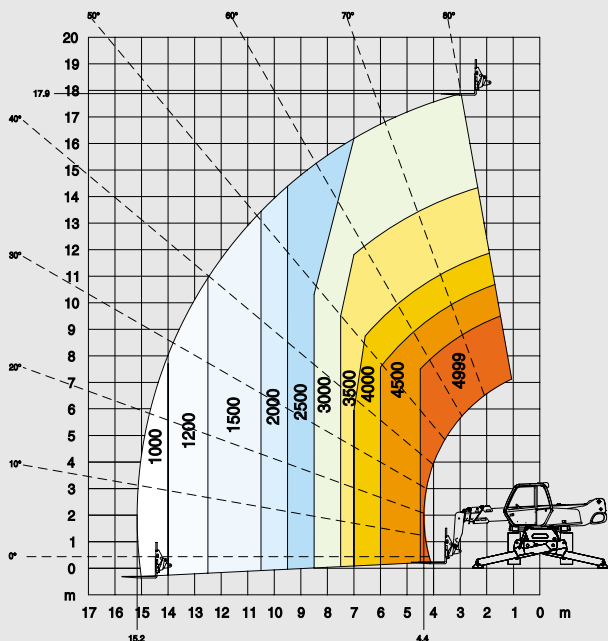

FRONTAL POSITION ON WHEELS WITH FORKS

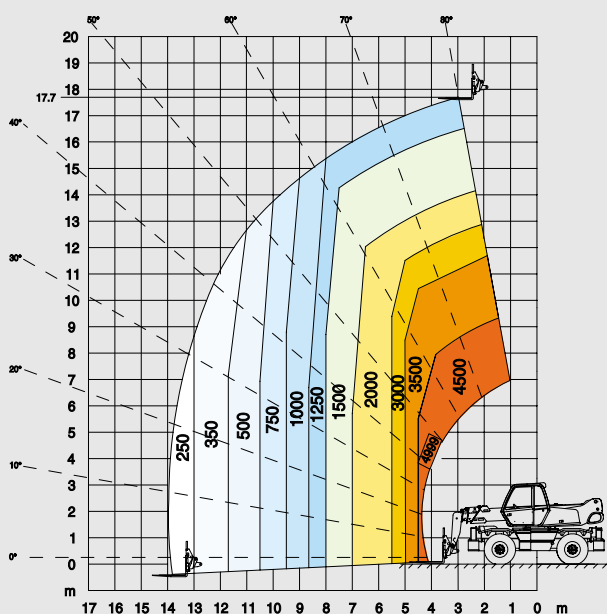

ROTATION ON STABILISERS NOT FULLY EXTENDED WITH FORKS

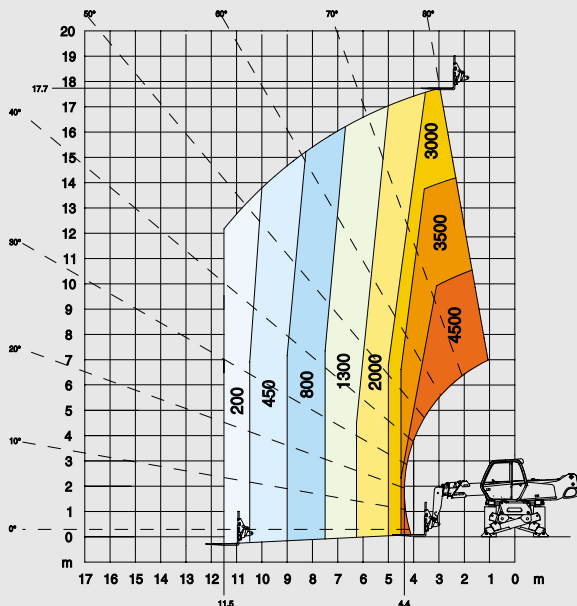

ROTATION ON STABILISERS FULLY EXTENDED WITH 5T WINCH

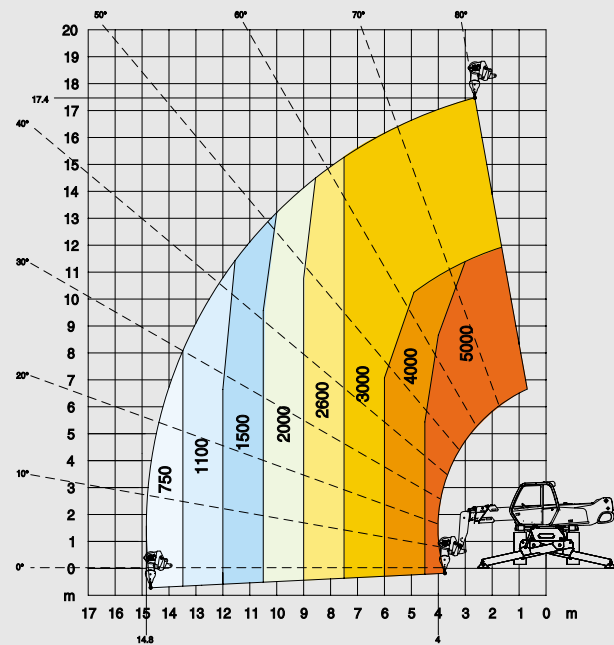

ROTATION ON STABILISERS FULLY EXTENDED WITH JIB P 600

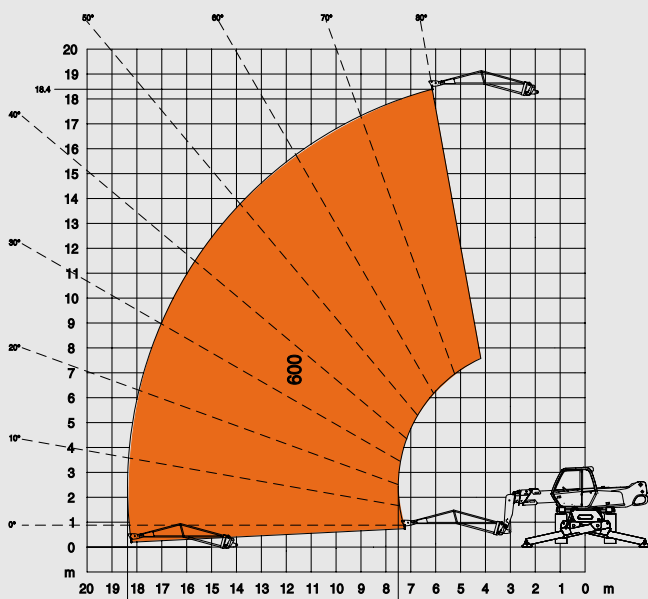

ROTATION ON STABILISERS FULLY EXTENDED WITH JIB P 1500

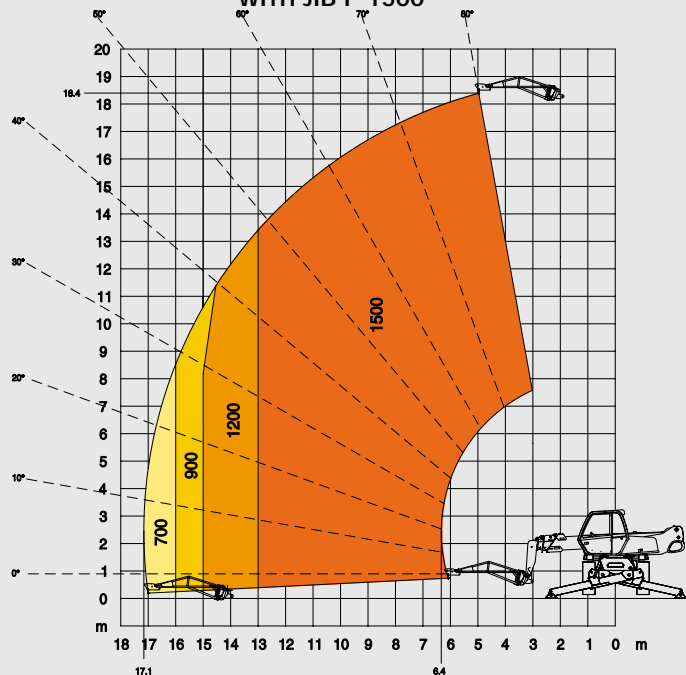

MRT 1850 M Series

ROTATION ON STABILISERS FULLY EXTENDED WITH EXTENSIBLE PLATFORM 2,25/4 m

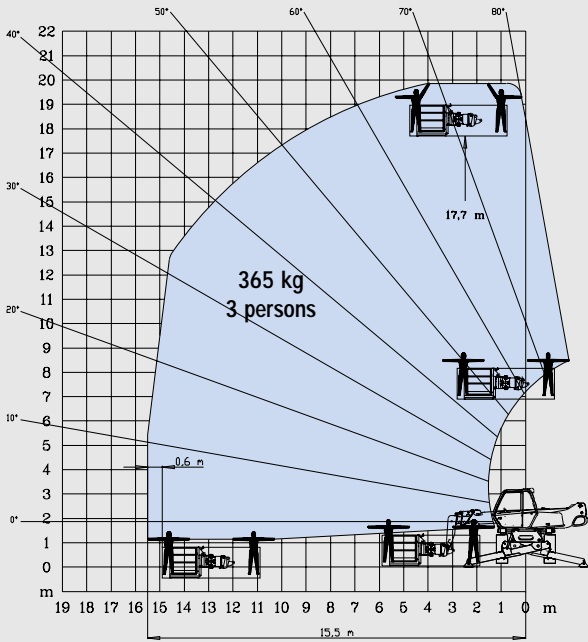

ROTATION ON STABILISERS FULLY EXTENDED WITH 1000 KG PLATFORM 2,25/4 m

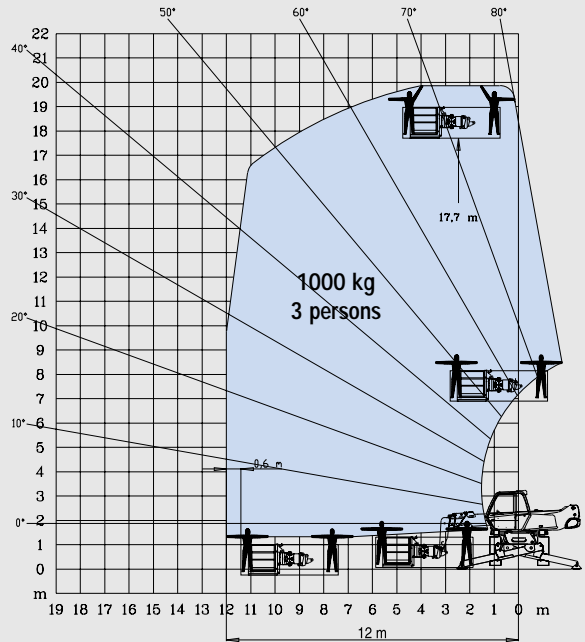

ROTATION ON STABILISERS FULLY EXTENDED WITH 3 D SYSTEM IN POSITIVE POSITION

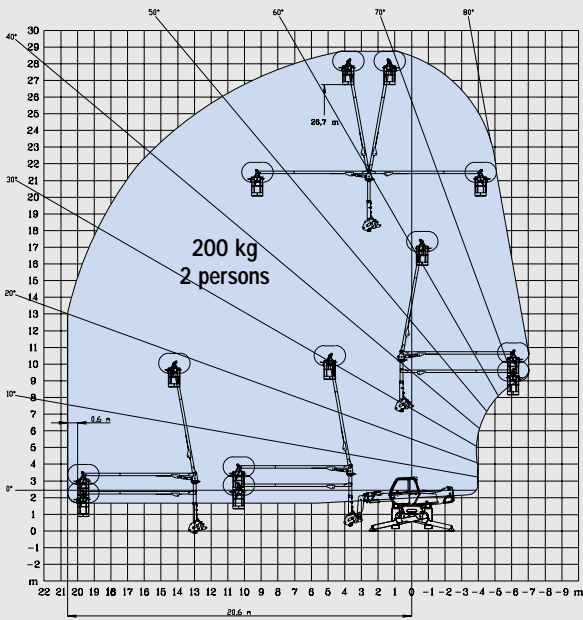

ROTATION ON STABILISERS FULLY EXTENDED WITH 3 D SYSTEM IN NEGATIVE POSITION

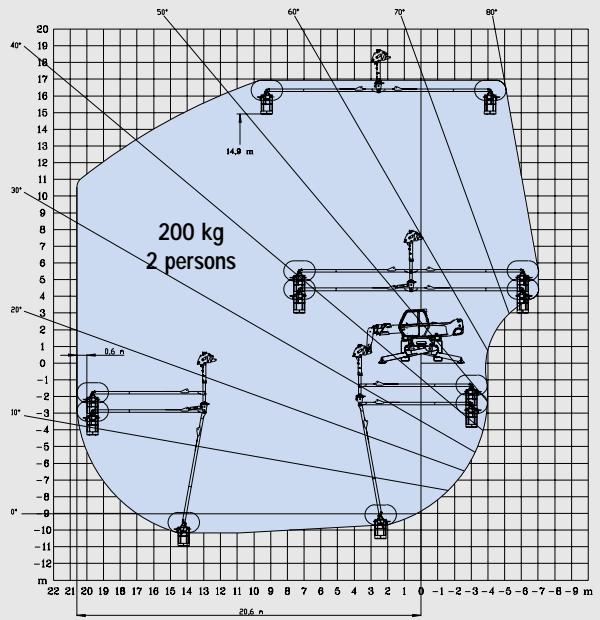

ROTATION ON STABILISERS FULLY EXTENDED WITH AERIAL JIB PLATFORM

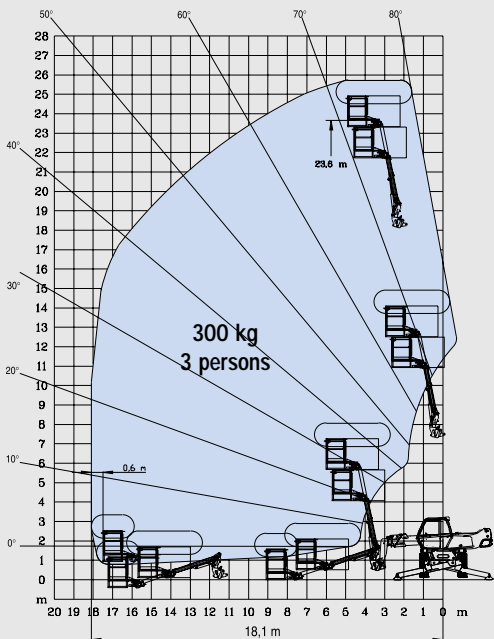

ROTATION ON STABILISERS FULLY EXTENDED WITH CRANE JIB

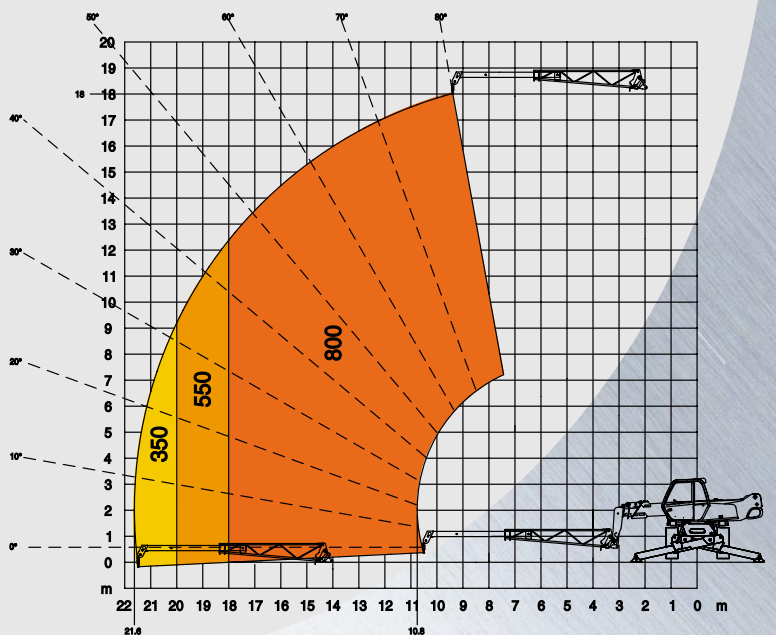

MRT 1850 *M Series*



Lift capacity (on stabilisers)4999 kg
at 500 mm from forks heels



Lift height :17.90 m



Tyres
18 - 22,5



Forks (mm)
Length1200
Width x thickness150 X 50



Multidisc brakes : hydraulically assisted on both axles
Negative parking brake



Engine PERKINS
Type1004.40 TW
Capacity4 cyl. 3990 cm³
Power (ISO 14396)123 HP/91 kw
at 2300 rpm
Water cooling
Direct injection



Transmissionhydrostatic
With automatic power regulation (hydraulic variable displacement pump and motor)
Reversing shiftelectromagnetic
2 speed forward and reverse
Travel speed25 km/h



Rear axle
Frame levelling on front axle +/- 8° (15%)
Automatic rear axle locking system
over 15 ° rotation



4 stabilisers
simultaneous or individually controlled



Total and continuous rotation
Turret mounted on a double slew ring
Hydraulic and electric rotation



Hydraulics
3 pumps gear type270 bars/160 l/mn



Control : 2 electro proportional control joysticks for all hydraulic movements



Capacities
Cooling system15 l.
Engine oil11.5 l.
Hydraulic oil200 l.
Fuel tank230 l.



Weight unladen (with forks)15350 kg
Overall width2.43 m
Overall height3.02 m
Overall length6.06 m
Ground clearance0.37 m
Drawbar pull10800 daN



Standard load moment indicator
(mobile crane standards)

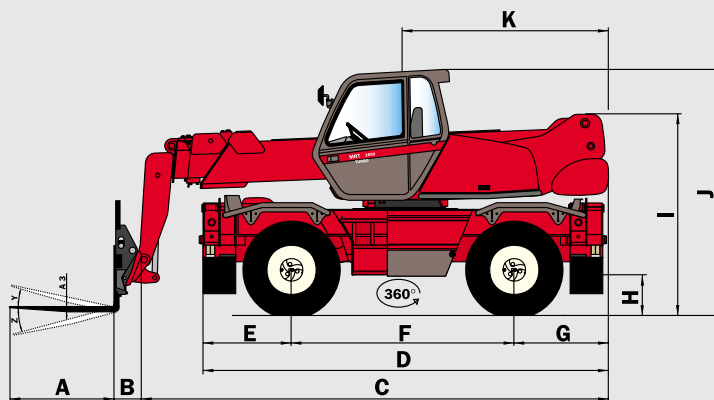

A	1200
A1	150
A2	1320
A3	60
B	290
C	5770
D	5050
E	1155
F	2750
G	1155
H	370
I	2420
J	3025
K	2485
L	1930
M	2425
N	4700
O	5100
P	200
Q	4500
R	3800
S	4550
V	950
Y	12°
Z	105°

mm

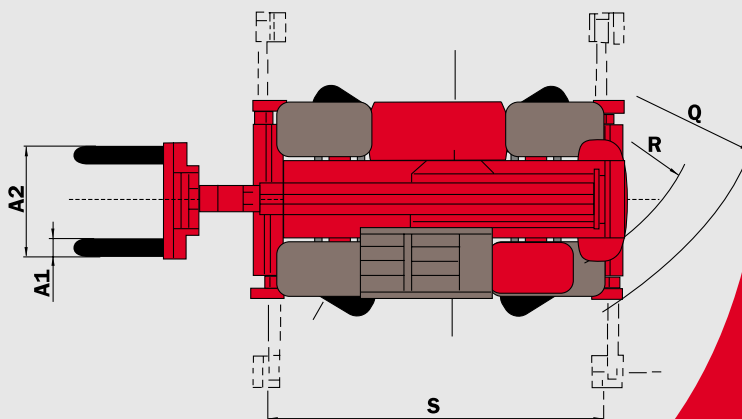
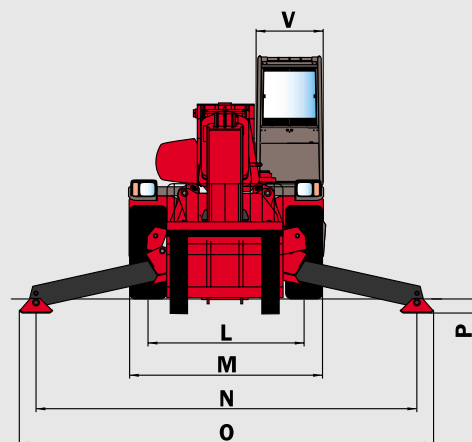

This publication in no way constitutes an offer and the company reserves the right to alter specification without prior notice.
The MANITOU models presented in this brochure can be supplied complete with optional equipment attachments.

