

# MANISCOPIC

# MLT 940 L-120 LSU

- Lifting height : 8.97 m
- Capacity : 4000 kg
- Maximum forward reach : 5.32 m
- Torque convertor
- 4 wheel-drive
- Engine : 123 HP
- Load Sensing Ultra : 150 l/mn - 270 bars
- FRAME LEVELLING 10°/10°

**LOAD SENSING ULTRA**

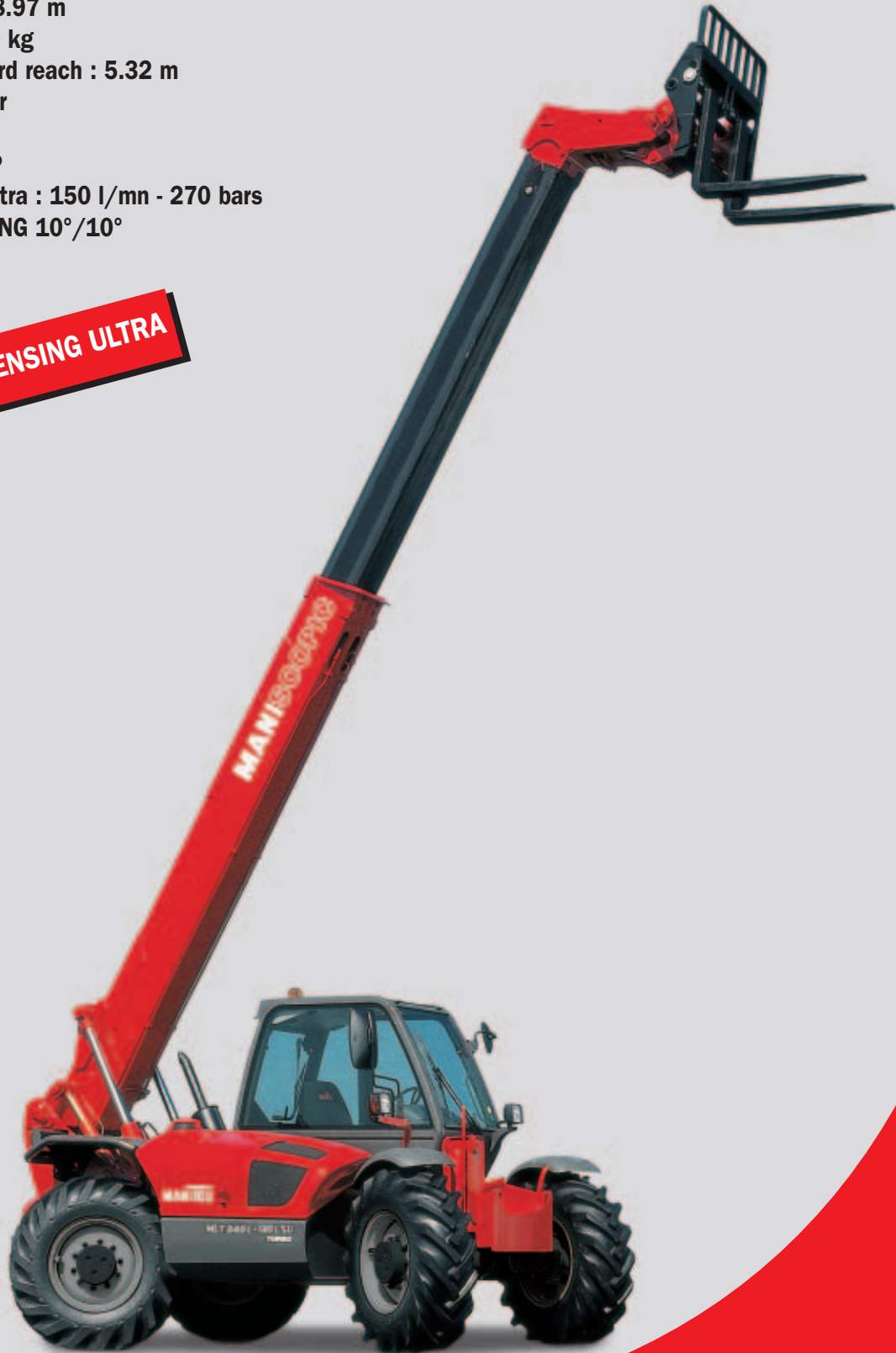

MLT 940 - 120 LSU - TFF 45 MT 1040



# MLT 940 L - 120 LSU

**Lift capacity** .....4000 kg  
 at 500 mm from forks heels  
 Tipping load  
 at maximum reach .....1342 kg  
 Tear out force with toothed digging bucket  
 to ISO 8313 with tilting ram .....7000 daN

**Lift height** .....8.97 m  
**Times** : unladen/loaded (in s)  
 Lifting.....8.4/9  
 Lowering.....6/5.8  
 Boom extension.....9.7/9.9  
 Boom retraction.....8.3/8.2  
 Time unladen (in s)  
 Crowd .....3.7  
 Dump.....3.3

**Tyres**  
 15,5/80 - 24 16PR SGI

**Forks** (mm)  
 Length .....1200  
 Width x thickness.....125 x 50  
 Maximum distance between forks.....1260  
 Carriage rotation .....142°

**Multidisc brakes hydraulically assisted on both axles**

**Perkins engine**  
 Turbo 120 : 1104 C - 44 TA .....4 cylindres 4400 cm<sup>3</sup>  
 Power (ISO TR 14396).....123 HP/90.5 kw  
 Maximum torque.....434 Nm at 1400 rpm  
 Direct injection  
 Water cooling

**Transmission** .....Torque convertor  
 Electro - hydraulic reversing shift  
 4 speeds forward and reverse  
 Maximum travel speed.....25 km/h\*

**Turbo 120 LSU** : .....150 l./mn - 270 bars  
 Load Sensing pump with electronic control  
 Electro proportional command monolever  
 Flow divider with load sensing device driving and braking

**Capacities**  
 Cooling system.....18.5 l.  
 Engine oil .....11.5 l.  
 Hydraulic oil .....131 l.  
 Transmission oil.....16 l.  
 Fuel tank.....135 l.

**Weight unladen** (with forks).....8955 kg  
**Overall width** .....2.39 m  
**Overall height** .....2.59 m  
**Turning radius** (outside wheels).....4.15 m  
**Overall length** .....5.65 m  
**Ground clearance** .....0.46 m  
**Drawbar pull** .....8600 daN

## Reach at maximum height : 0,65 m

Under  
 EN 1459  
 annexe B

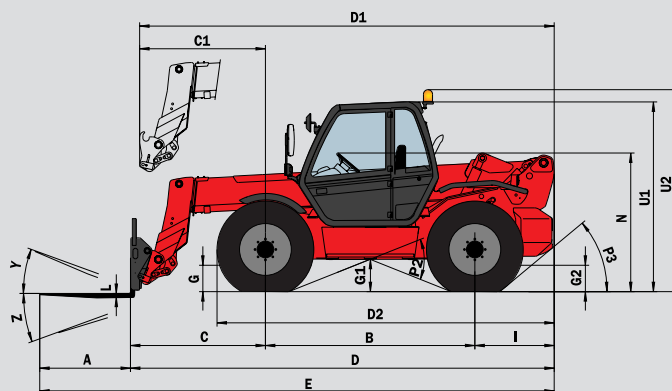
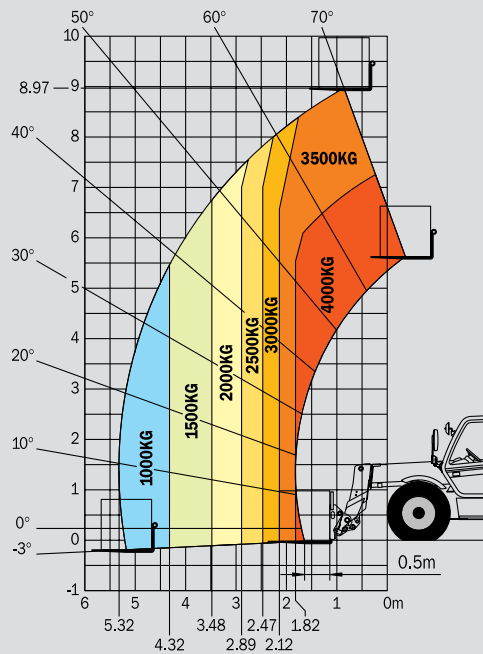

MLT 940 L - 120 LSU

A	1200
B	2770
C	1834
C1	1893
D	5654
D1	5713
D2	4420
E	6854
F	1990
F1	1990
G	465
G1	460
G2	465
H	10°
H1	10°
I	1050
J	950
K	1260
L	50
N	1875 - 1925
O	125
P2	43,5°
P3	40°
R	3950
S	8569
T	4037
U1	2590
U2	2770
V	5507
V1	1470
V2	4150
W	2390
Y	12°
Z	130°

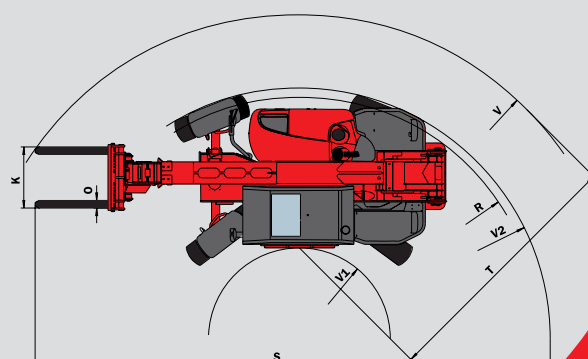
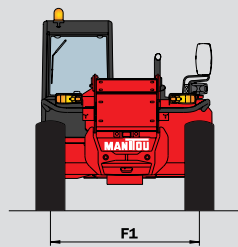
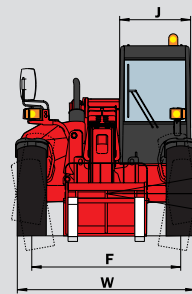

This publication in no way constitutes an offer and the company reserves the right to alter specification without prior notice.  
 The MANITOU models presented in this brochure can be supplied complete with optional equipment attachments.  
 PATENTS FR 93 14367 - EP 0 656 315 - US PENDING

