

MANISCOPIC

MLT 742 TURBO

- Maximum lifting height : 6.90 m
- Capacity : 4200 kg
- Maximum forward reach : 3.93 m
- Torque convertor





MLT 742 TURBO - PFB 45 MT 1670





MLT 742 Turbo

 **Lifting capacity**4200 kg
(load centre at 500mm from forks heels)
Tipping load at maximum reach.....1990 kg

 **Lifting height** :6.90 m
Times : unladen/loaded (in s)
Lifting.....7/7.5
Lowering.....5.3/5.2
Boom extension.....8.2/9.0
Boom retraction.....6.2/6.0
Time unladen (in s)
Crowd.....3.5
Dump.....3.0

 **Tyres**
14.9 – 24 T 35 18 PR

 **Forks** (mm)
Length.....1200
Width X thickness125 x 45
Maximum distance between forks1260
Carriage rotation146°

 **Oil bath multidisc brakes on front and rear axles**

 **Perkins engine**
Turbo 120 : 1104 C - 44 TA.....4 cyl. - 4400 cm³
Power (ISO/TR 14396)101 HP/74,5 kw
Maximum torque
(ISO/TR 14396) :412 Nm at 1400 rpm
Direct injection
Water cooling

 **Transmission**torque convertor
Number of speeds.....4/4
Reversing shift.....electrohydraulic
Limited slip differential lock
Maximum speed25 km/h

 **Hydraulic**
Turbo :105 l./mn - 250 bars
Gear pump
Flow divider with priority to braking and steering

 **Capacities**
Hydraulic oil.....125 l
Fuel tank.....120 l

 **Weight unladen** (with forks)7585 kg
Overall height2.30 m
Overall width2.26 m
Overall length (at forks carriage).....4.80 m
Ground clearance0.45 m
Turning radius (outside wheels)3.81 m
Drawbar pull9100 daN

Forward reach at maximum height : 1,03 m

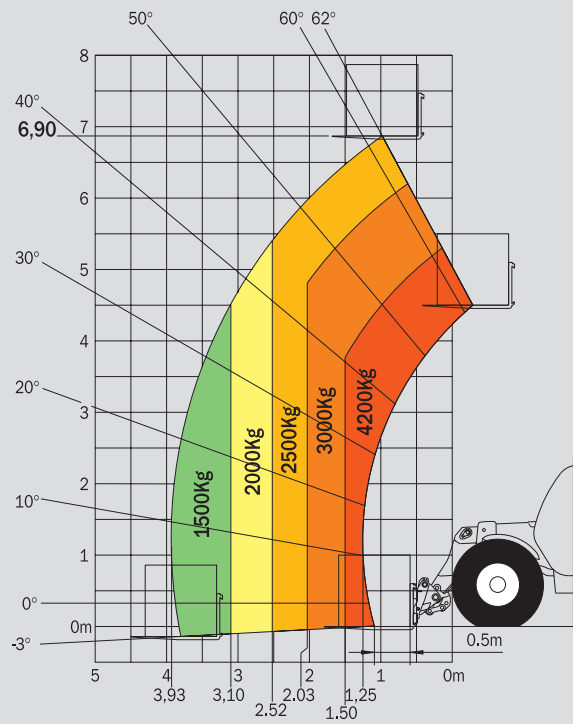

EN 1459 annexe B

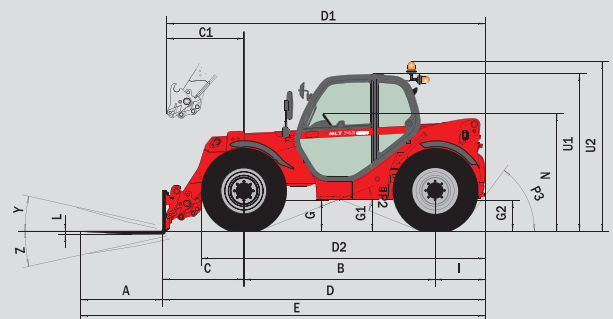

MLT 742 T

A	1200
B	2810
C	1232
D	1288
D1	4805
D2	4861
E	4158
F	6005
F1	1846
G	1846
G1	455
G2	440
I	440
J	763
K	865
L	1260
N	50
O	1690
P2	125
P3	38°
R	53°
S	3610
T	7654
U1	3505
U2	2300
V	2550
V1	4865
V2	1360
W	3818
Y	2261
Z	12,3°
	133,5°

mm

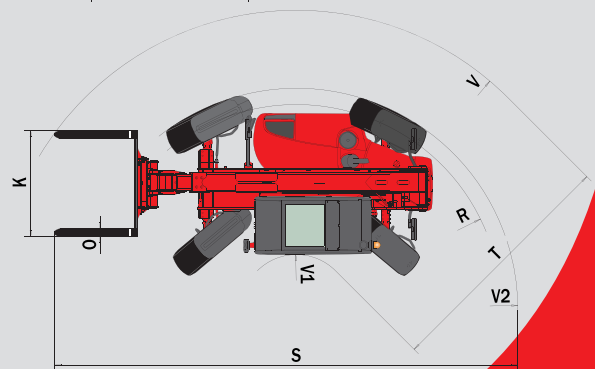
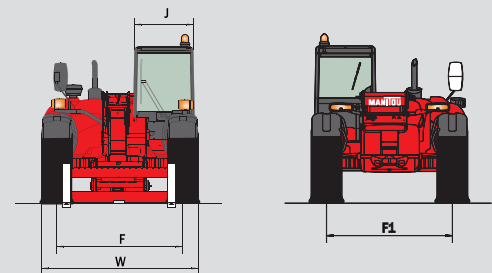

This publication in no way constitutes an offer and the company reserves the right to alter specification without prior notice. The MANITOU models presented in this brochure can be supplied complete with optional equipment attachments.

