

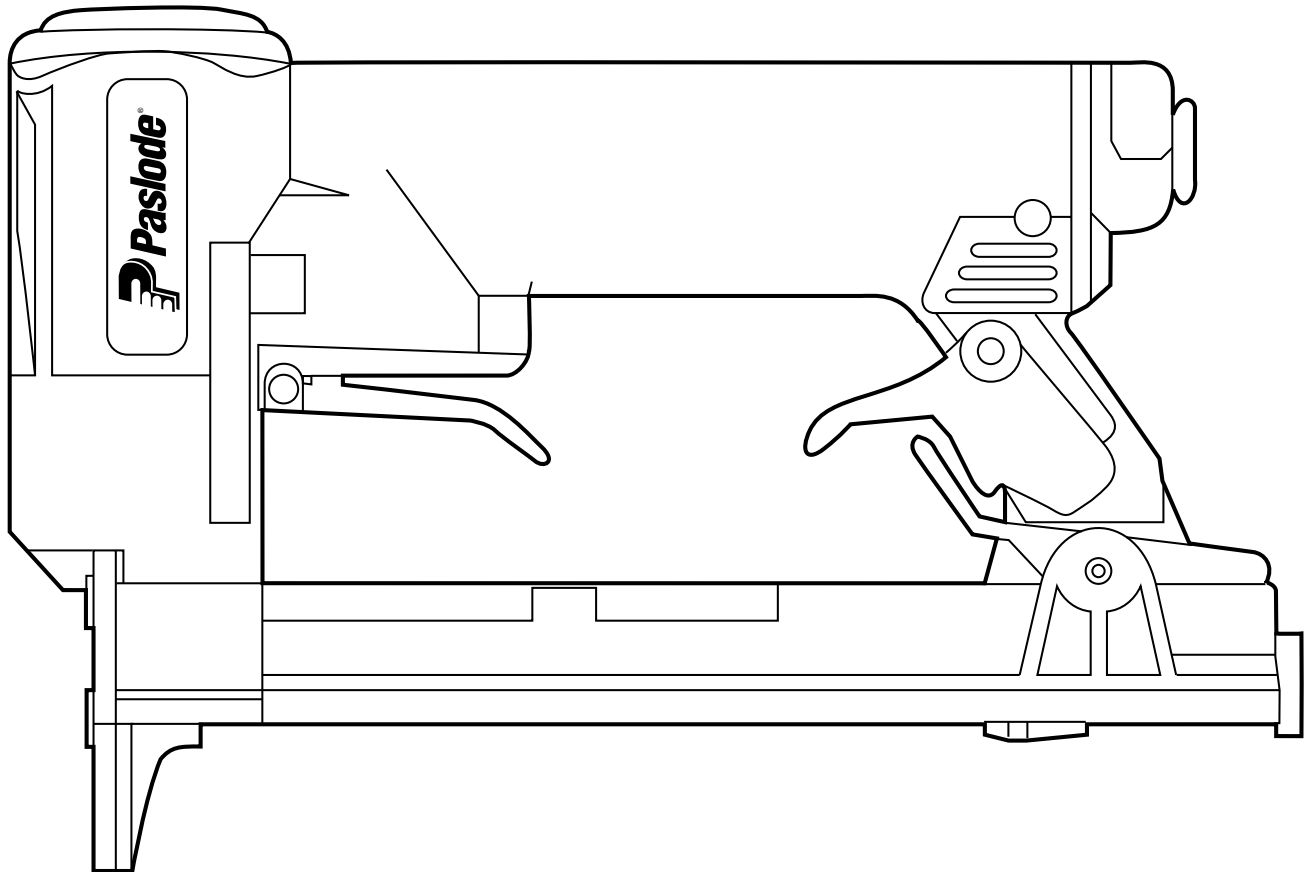

**MODEL 1000 SR Series  
Staplers**



**Operating and  
Maintenance Manual**

**IMPORTANT  
DO NOT DESTROY**

It is the customer's responsibility to have all operators and service personnel read and understand this manual.

# PARTS LEGEND

Narrow Crown	
<b>1000-N30SR, 500017</b> Drives 30 gauge staples up to 3/4" in length. 5/32" crown size.	<b>1000-N50SR, 500018</b> Drives 50 gauge staples up to 3/4" in length. 5/32" crown size.
Standard Crown	
<b>1000-S30SR, 500019</b> Drives 30 gauge staples up to 5/8" in length. 9/32" crown size.	<b>1000-S50SR, 500020</b> Drives 50 gauge staples up to 5/8" in length. 9/32" crown size.
Wide Crown	
<b>1000-W30SR, 500021</b> Drives 30 gauge staples up to 5/8" in length. 1/2" crown size.	<b>1000-W50SR, 500022</b> Drives 50 gauge staples up to 5/8" in length. 1/2" crown size.

1	500023	1	Cap	32	403922	1	Nut, Self Locking
2	403906	1	Cap Gasket	33	403910	1	Air Diffuser
3	500024	1	Sleeve Spacer	34	500028	1	Air Diffuser Retainer
4	403918	1	O-Ring, Piston	35	500083	1	End Plug
* 5	500241	1	Driver Blade (N30)	▲36	403927	4	S.H.C.S. M4 x 14
	500240	1	Driver Blade (N50)	37	403923	4	Lockwasher
	500242	1	Driver Blade (S30)	38	500046	1	Front Guide (N30)
	500243	1	Driver Blade (S50)		500048	1	Front Guide (N50)
	500244	1	Driver Blade (W30)		500052	1	Front Guide (S30)
	500245	1	Driver Blade (W50)		500054	1	Front Guide (S50)
* 6	403920	1	O-Ring, Upper		500058	1	Front Guide (W30)
7	500025	1	Sleeve		500060	1	Front Guide (W50)
* 8	403921	1	O-Ring	39	500027	1	Back Plate
* 9	403909	1	Bumper	**40	403960	1	Warning Label
10	500026	1	Housing	41	500050	1	Housing, Rail Assembly (N)
11	403962	2	Logo, Housing		500056	1	Housing, Rail Assembly (S)
*12	500041	3	O-Ring		500062	1	Housing, Rail Assembly (W)
*13	403917	2	O-Ring, Valve Piston	42	403901	1	Rail Stop (N)
14	500030	1	Valve Piston		403963	1	Rail Stop (S,W)
15	403966	1	Buffer	43	403959	1	Rail Latch (N,S)
16	500040	1	O-Ring, Valve Piston		403944	1	Rail Latch (W)
17	500031	1	Valve Stud	44	403908	1	Torsion Spring, Rail Latch
18	500032	1	Spring, Valve Pin	45	403936	1	Follower (N)
*19	500042	1	O-Ring, Valve Pin		403946	1	Follower (S)
20	500033	1	Valve Pin		403954	1	Follower (W)
*21	500034	1	Seat, Valve Pin	46	403935	1	Compression Spring,Follower(N)
22	500037	1	Trigger Pin		403945	1	Extension Spring,Follower (S,W)
23	500035	1	Trigger Plate	47	500049	1	Rail Assembly (N)
24	500038	1	Retainer, Trigger Pin		500055	1	Rail Assembly (S)
→ 25	500043	1	F.H.C.S. M4 x 12		500061	1	Rail Assembly (W)
26	500036	1	Trigger	48	403925	1	Spirol Pin (N)
27	500029	1	Valve Sleeve	49	403932	1	Guide Bar, Follower Spring(N)
*28	500039	1	O-Ring, Valve Sleeve	50	403964	2	Follower Insert (N)
29	500080	1	S.H.C.S. M5 x14	51	500246	1	Piston
30	403924	2	Spirol Pin	52	500247	1	Pin
31	403907	1	Quick Release Latch	→ 53	500763	1	O-Ring

\* Denotes Normal Wear Items

\*\* Note: Make sure Warning Label (403960) is properly affixed.  
Replace if necessary. Label available at no charge through the Service Dept.

▲ Apply loctite 242 (Blue) Part No. 093500

→ Denotes new change

1000-N30 SR  
 500017  
 1000-N50 SR  
 500018  
 1000-S30 SR  
 500019  
 1000-S50 SR  
 500020  
 1000-W30 SR  
 500021  
 1000-W50 SR  
 500022

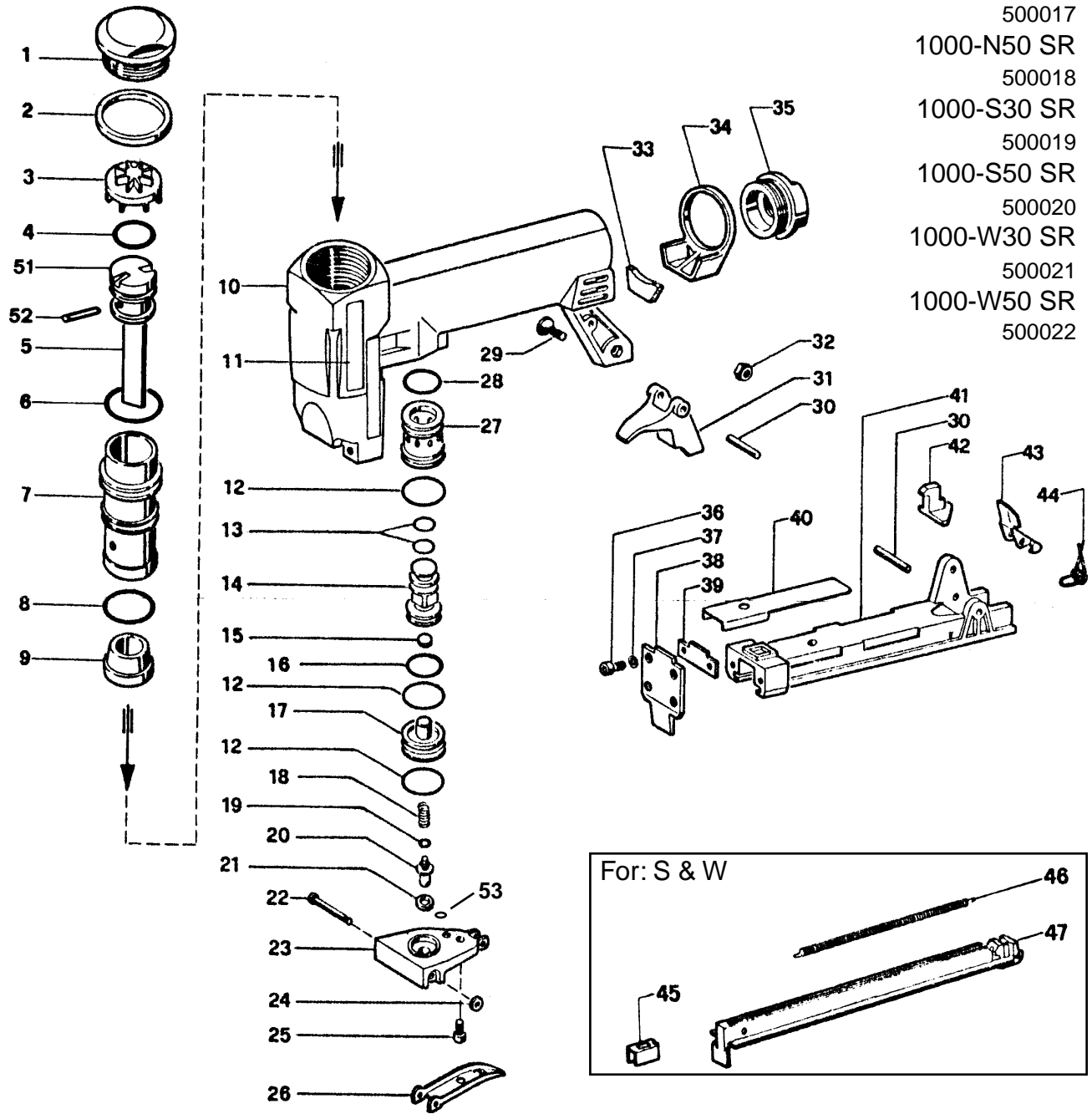

**⚠ WARNING**  
 All parts must be periodically inspected and replaced if worn or broken. Failure to do this can affect the tool's operation and present a safety hazard.

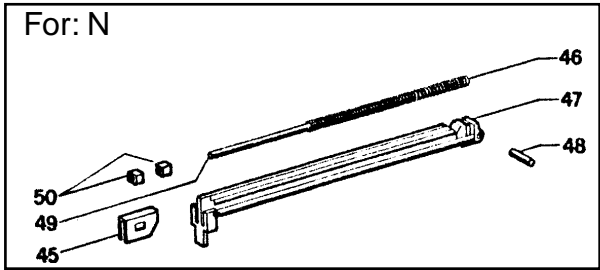
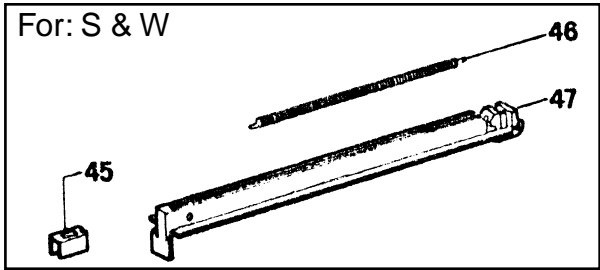

# TROUBLE SHOOTING CHART

SYMPTOM	POSSIBLE CAUSE	REMEDY
1. Tool sometimes misses a staple	Follower damaged (Key#45) Dirt or glue in housing (Key#41) Follower spring worn or damaged (Key#46)	Replace Clean housing & rail Replace
2. Piston does not fully return.	Bumper worn (Key#9) Driver blade bent or burred Worn O-Ring (Key#4) Air diffuser dirty or clogged (Key#33)	Replace bumper Replace Driver blade Replace O-Ring Clean or replace
3. Air leaks out of rear exhaust	O-Ring cut, broken or worn (Key#13) Trigger valve piston broken or worn (Key#14) O-Ring cut, broken or worn (Key#16)	Replace O-Ring Replace trigger valve Replace O-Ring
4. Piston will not return at all	Malfunction in trigger valve piston (Key#14) Bumper worn (Key#9)	Replace trigger valve Replace bumper
5. Too much overdrive	Excessive air pressure in light wood	Reduce air pressure
6. Excessive blade breakage	Due to excessive air pressure	Reduce air pressure to minimum required for job

## TOOL WARRANTY AND LIMITATIONS

Paslode warrants that newly purchased power fastening tools parts and accessories will be free from defects in material and workmanship (excluding wear parts) for the period shown below, after the date of delivery to the original user.

### 90-DAY LIMITED WARRANTY

A 90-day warranty will apply to all parts, except those which are specifically covered by an extended warranty.

### EXTENDED LIMITED WARRANTY FOR ON SITE CONSTRUCTION APPLICATIONS

A one year warranty will apply to all housing and cap assembly castings. A six month warranty will apply to all magazines parts.

### NORMAL WEARING PARTS

The following parts are considered normal wearing parts and are not under warranty:

- Bumper
- Drive Blades
- "O" Rings
- Piston Rings

### WARRANTY STATEMENT

Paslode's sole liability hereunder will be to replace any part or accessory which proves to be defective within the specific time period. Any replacement part or accessory provided in accordance with this warranty will carry a warranty for the balance of the period of warranty applicable to the part it replaces.

This warranty is void as to any tool which has been subjected to misuse, abuse, accidental or intentional damage, used with fasteners not meeting Paslode specification, size, or quality, improperly maintained, repaired with other than genuine Paslode replacement parts, damaged in transit or handling, or which, in Paslode's opinion, has been altered or repaired in a way that affects or detracts from the performance of the tool.

PASLODE MAKES NO WARRANTY, EXPRESSED OR IMPLIED, RELATING TO MERCHANTABILITY, FITNESS, OR OTHERWISE, EXCEPT AS STATED ABOVE, and Paslode's liability AS STATED ABOVE AND AS ASSUMED ABOVE is in lieu of all other warranties arising out of, or in connection with, the use and performance of the tool, except to the extent otherwise provided for by applicable law. PASLODE SHALL IN NO EVENT BE LIABLE FOR ANY DIRECT, INDIRECT, OR CONSEQUENTIAL DAMAGES, INCLUDING, BUT NOT LIMITED TO, DAMAGES WHICH MAY ARISE FROM LOSS OF ANTICIPATED PROFITS OR PRODUCTION, SPOILAGE OF MATERIALS, INCREASED COST OF OPERATION, OR OTHERWISE.

Paslode reserves the right to change specifications, equipment, or designs at any time without notice and without incurring obligation.

# OPERATOR SAFETY INSTRUCTIONS

## SAFETY FIRST

These safety instructions provide information necessary for safe operation of Paslode® tools. **DO NOT ATTEMPT TO OPERATE THE TOOL UNTIL YOU READ AND UNDERSTAND ALL SAFETY PRECAUTIONS AND MANUAL INSTRUCTIONS.**



### WEAR EYE AND HEARING PROTECTION

Always wear hearing and eye protection devices, including side shields, when operating or working in the vicinity of a tool.

### THE TOOL MUST BE USED ONLY FOR THE PURPOSE FOR WHICH IT WAS DESIGNED

Do not throw the tool on the floor, strike the housing in any way or use the tool as a hammer to knock material into place.

### NEVER ENGAGE IN HORSEPLAY WITH THE TOOL

The tool is not a toy so do not use it like one. Never engage in horseplay with the tool or point it at yourself or any other person, even if you think it is not loaded.

### NEVER ASSUME THE TOOL IS EMPTY

Check the magazine for fasteners that may be left in the tool. Even if you think the tool is empty or disconnected, never point it at anyone or yourself. Unseen fasteners could fire from the tool.

### NEVER CLAMP THE TRIGGER IN A LOCKED OR OPERATING POSITION

The trigger of the tool must never be tampered with, disabled or clamped in a locked or operating position since this will cause the tool to drive a fastener any time the work contacting element depressed.

### DO NOT LOAD FASTENERS WITH THE AIR LINE CONNECTED, OR WITH THE TOOL TRIGGER OR WORK CONTACTING ELEMENT DEPRESSED

When loading fasteners into the tool be sure you disconnect the air line and that you do not depress the trigger or work contacting element.



### OPERATE THE TOOL ONLY ON A WORKPIECE

The tool should be operated only when it is in contact with the workpiece. Even then you should be careful when fastening thin material or working near the edges and corners of the workpiece since the fasteners may drive through or away from the workpiece.

### DO NOT DISABLE OR REMOVE THE WORK CONTACTING ELEMENT

This tool is equipped with a safety mechanism, called a work contacting element, to help prevent accidental firing. Never tamper with, disable or remove the work contacting element. Do not use the tool unless the work contacting element is working properly. The tool could fire unexpectedly.

## DISCONNECT THE TOOL WHEN NOT IN USE

Always disconnect the tool from the air line when it is not in use or when you leave the work area. The tool should never be left unattended because people who are not familiar with the tool might handle it and injure themselves or others.



## CARRY THE TOOL ONLY BY THE HANDLE

Always carry the tool by the handle only. Never carry the tool by the air hose or with the trigger depressed since you could drive a fastener unintentionally and injure yourself or someone else.

## DO NOT WEAKEN THE TOOL HOUSING

The tool housing is a pressure vessel and should never be weakened by having your company's name, area of work or anything else stamped or engraved into its surface.

## DISCONNECT THE TOOL WHEN PERFORMING REPAIRS AND CLEARING JAMS

Never attempt to clear a jam or repair a tool unless you have disconnected the tool from the air line and removed all remaining fasteners from the tool.

## ALWAYS USE THE PROPER FITTING FOR THE TOOL

Only MALE pneumatic type air connectors should be fitted to the tool, so that high pressure air in the tool is vented to atmosphere as soon as the air line is disconnected.

NEVER install FEMALE quick disconnect couplings on the tool. Female couplings will trap high pressure air in the tool when the air line is disconnected, leaving the tool charged and able to drive at least one fastener.



## DO NOT EXCEED THE MAXIMUM RECOMMENDED AIR PRESSURE

Operate the tool only at the recommended air pressure. Do not exceed the maximum air pressure marked on the tool. Be sure the air pressure gauge is operating properly and check it at least twice a day.

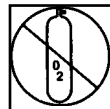

Never use any bottled air or gases such as oxygen to operate the tool since they could cause the tool to explode.

## KEEP THE TOOL CLEAN AND LUBRICATED

Clean the tool at least daily and lubricate as required. Never operate a dirty or malfunctioning tool.

## USE ONLY PASLODE RECOMMENDED PARTS AND FASTENERS

Use only parts and fasteners specifically designed and recommended by Paslode for use in the tool and for work to be done. Using unauthorized parts and fasteners or modifying the tool in any way creates dangerous situations. Replace all missing warning labels---refer to tool schematic for correct placement and part number.

## DANGER

Failure to follow any of the above instructions could result in severe personal injury to tool user and bystanders or cause damage to tool and property.

Contact your local Paslode Representative for presentation of Paslode's Safety Awareness Program

## INSTALLATION

The 1000SR Series staplers have been designed for a **maximum safe operating pressure of 100 p.s.i.** Always use the minimum air pressure necessary to do the job properly.

A filter, pressure regulator and lubricator unit with gauge should be installed as close as possible to the tool. Every tool must be equipped with a male quick disconnect nipple installed at the air inlet of the tool. The nipple should be a pneumatic type which discharges the air from the tool when it is disconnected. Air lines should be a minimum of 3/16" in diameter and should be kept as short as possible. Air line ahead of the regulator should be a minimum of 1/4".

In general, no special installation is required. If the operator is working at a bench or table, it is usually easiest to feed the air from underneath the bench. A small tray can be fastened under the bench top to hold the tool when not in use. This same tray can also hold the staple supply.

**If this tool malfunctions upon installation, do not attempt to disassemble and make repairs. Please call your local Paslode representative.**

## MAINTENANCE

The 1000SR Series staplers have been designed with ease of maintenance in mind. A few simple maintenance details will assure trouble free operation and long tool life. Any person repairing the tool must study the Operating and Maintenance Manual and be familiar with the general parts arrangement (depicted elsewhere in this manual).

Prior to beginning repairs.

1. Keep lubricator filled with Paslode Pneumatic Tool Lubricating Oil (Part #219026). Make certain that lubricator is operating in accordance with the manufacturers recommendations.
2. Keep magazine rail and follower clean. General practice is to blow it clean daily.
3. If for any reason it is necessary to remove any moving part, it should be lubricated with Chemplex 710 grease, (Part #403734).
4. Tool repair, if necessary, should only be made with original Paslode parts.

## CLEARING JAMS

The 1000SR Series stapler is designed to be virtually **jam proof**. If a jam should occur, disconnect the tool from air line, invert the tool, depress the quick release rail latch allowing the rail assembly to slide back. Relieve the jam by removing the staple.

## LOADING

One of the finest features of the 1000SR Series stapler is the ease with which it can be loaded.

To load, depress the quick release rail latch using the little finger of working hand.

The magazine rail will exit automatically from the housing.

Insert the staples into the rail opening.

Push rail forward until it latches.

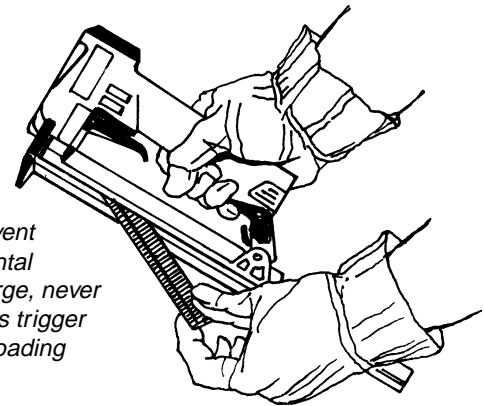

*To prevent accidental discharge, never depress trigger when loading*

## SAFETY

All tool operators and their immediate foremen must become familiar with the **OPERATOR SAFETY INSTRUCTIONS** for Paslode Staplers and Nailers prior to operating the tool. These instructions are contained elsewhere in this manual.



An Illinois Tool Works Company  
888 Forest Edge Drive  
Vernon Hills, Illinois 60061