

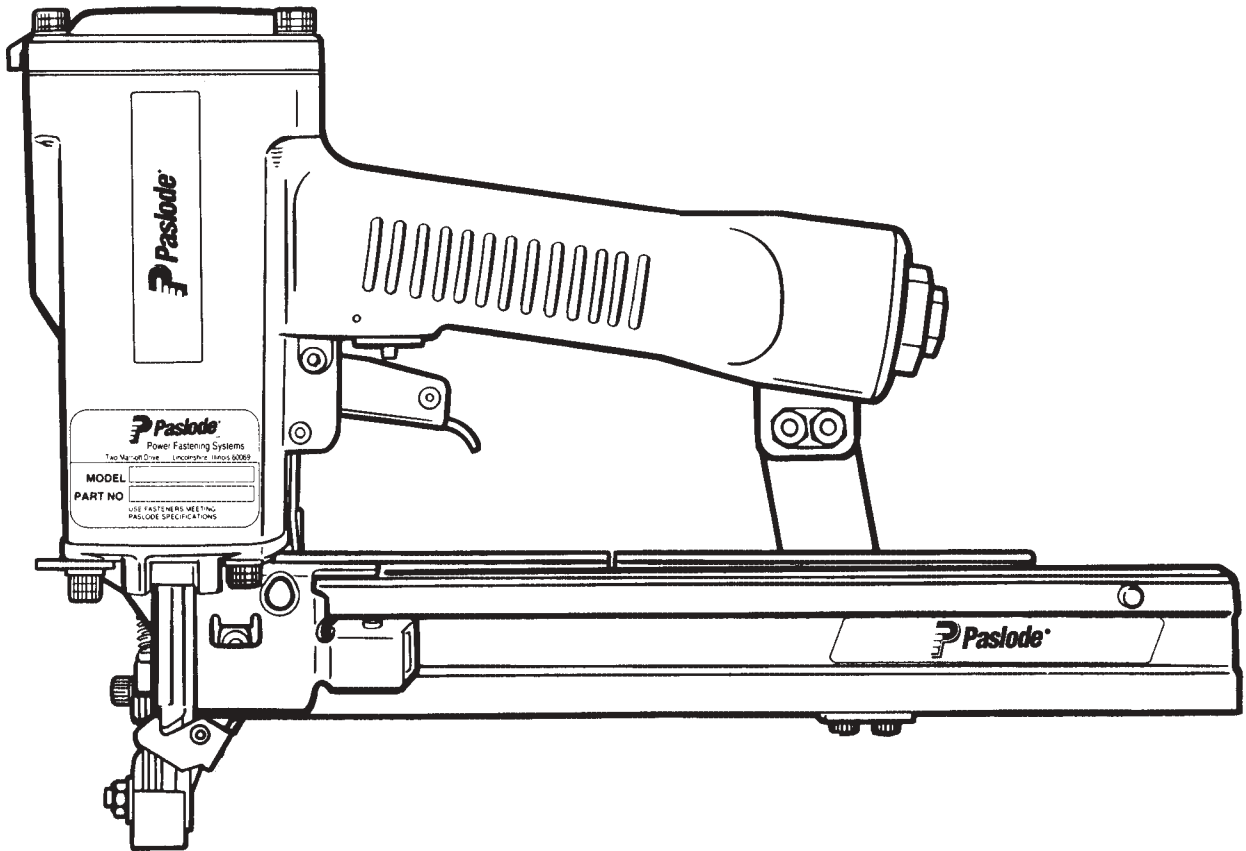

MODEL 3150/38-S16
MODEL 3200/50-S16P
STAPLERS



TOOL SCHEMATIC AND PARTS

IMPORTANT!

DO NOT DESTROY

Always refer to safety and maintenance manuals #403606, #405222 and #405218 for detailed information on these tools. It is the customer's responsibility to have all operators and service personnel read and understand this information.

PARTS LEGEND

3150/38-S16, 403200
3200/50-S16P, 403210

1	091362	4	Socket Head Capscrew, 1/4-20 x 1-1/2" (S16)	47	402741	1	Rail Bracket (S16)
	404229	4	Socket Head Capscrew, 1/4-20 x 2-1/4" (S16P)		402781	1	Rail Bracket (S16P)
3	404242	1	Diffuser Cap	48	004224	3	Socket Head Capscrew, #10-32 x 3/8"
4	006310	1	Socket Head Capscrew, #6-32 x 1/2"	49	404054	1	Seal, Main Valve
6	402704	1	Cap (S16)	50	090927	1	"O" Ring, Main Valve
	402705	1	Cap (S16P)	52	402629	2	Hardened Washer
7	402717	1	Conical Spring	53	402794	1	Intermediate Work Contacting Element
*8	404230	1	Retaining Ring	*54	402738	1	Spring
*9	091537	1	"O" Ring, Main Valve Assembly	55	402736	1	Flat Washer, #10
10	404122	1	Upper Valve Piston	56	402793	1	Work Contacting Element (S16)
11	404055	1	Post, Main Valve		403207	1	Work Contacting Element (S16P)
*12	404256	1	"O" Ring, Main Valve Post	57	402792	1	Upper Work Contacting Element
*13	402723	1	"O" Ring, Piston	58	402734	1	Spring
14	403563	1	Piston	59	402787	1	Front Guide (S16)
15	403582	1	Jam Nut		403204	1	Front Guide (S16P)
*16	402784	1	Driver Blade (S16)	▲ 60	404232	2	Socket Head Capscrew, #8-32 x 13/16"
	403202	1	Driver Blade (S16P)	61	404698	2	Roll Pin, Assembly
17	402725	1	Seal, Sleeve	62	402788	1	Back Plate (S16)
18	405245	1	Sleeve (S16)		403205	1	Back Plate (S16P)
	405246	1	Sleeve (S16P)	63	402730	1	Pivot Pin, Front Guide
*19	402728	1	"O" Ring, Flange	64	092176	1	Roll Pin, 5/32" Dia. x 1-3/8" Lg.
*20	402729	1	"O" Ring, Sleeve	65	405078	1	Spring, Front Guide Latch (S16)
21	403854	1	Retaining Bumper		405079	1	Spring, Front Guide Latch (S16P)
22	403853	1	Bumper	66	402789	1	Latch, Front Guide (S16)
23	402785	1	Seal, Drive Blade		403206	1	Latch, Front Guide (S16P)
24	402707	1	Gasket, Cap	**67	500459	1	Warning Label
25	402701	1	Housing	68	402748	1	Pivoting Rail Cover Assembly (S16)
26	404939	2	Logo, Housing		402780	1	Pivoting Rail Cover Assembly (S16P)
27	500688	1	Nameplate (S16)	69	403426	1	Rail and Rail Cover Assembly (S16)
	500689	1	Nameplate (S16P)		403427	1	Rail and Rail Cover Assembly (S16P)
28	402708	1	Gasket, Flange	70	402731	1	Logo, Rail
29	402706	1	Flange	71	402740	2	Roll Pin, 3/32" Dia. x 7/16" Lg.
30	091545	4	Socket Head Capscrew, 1/4-20 x 7/8"	72	402798	1	Latch, Follower Button
31	405144	1	Trigger	73	402799	1	Spring, Follower Latch
32	402079	1	Pin, Trigger	74	402797	1	Retaining Bushing
33	402668	1	Retaining Washer	75	091568	1	Binding Head Screw, #6-32 x 1/4"
34	405147	1	Lever, Trigger	*76	091532	1	Negator
35	005849	1	Roll Pin	77	091534	1	Drum, Negator
36	091966	1	"O"-Ring	78	402743	1	Pin, Negator Drum
37	026133	2	Roll Pin, 1/8" Dia. x 1" Lg.	79	402796	1	Follower
38	401958	1	Valve Body	80	404325	1	Stop Nut
*39	092174	1	"O" Ring, Valve Body	81	091447	4	Flat Washer, 1/4"
40	097746	1	Valve Pin	82	404243	4	Spacer, Diffuser
41	097748	1	Spring, Valve Pin	*84	092775	1	"O" Ring, Main Valve
*42	091591	1	"O" Ring, End Plug	*85	092773	1	"O" Ring, Main Valve
43	401940	1	End Plug	86	404056	1	Lower Valve Piston
44	091622	1	Reducing Pipe Bushing	88	405243	1	Flange
45	004502	2	Socket Head Capscrew, #10-32 x 5/8"	89	500488	1	Grip, Handle
46	092037	3	Lock Nut, #10-32	90	403716	2	Socket Head Capscrew #10-32 x 5/16"

- * Denotes normal wear items.
- ** Make sure warning label (500459) is properly affixed. Replace if necessary. Label available at no charge through the Service Dept.
- ▲ Apply Loctite 242 (Blue)
- ➔ Denotes new change

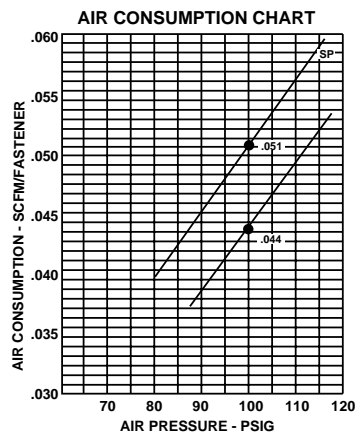

3150/38-S16

403200

3200/50-S16P

403210

Cap Assembly
#402709 (S16)
#402710 (S16P)

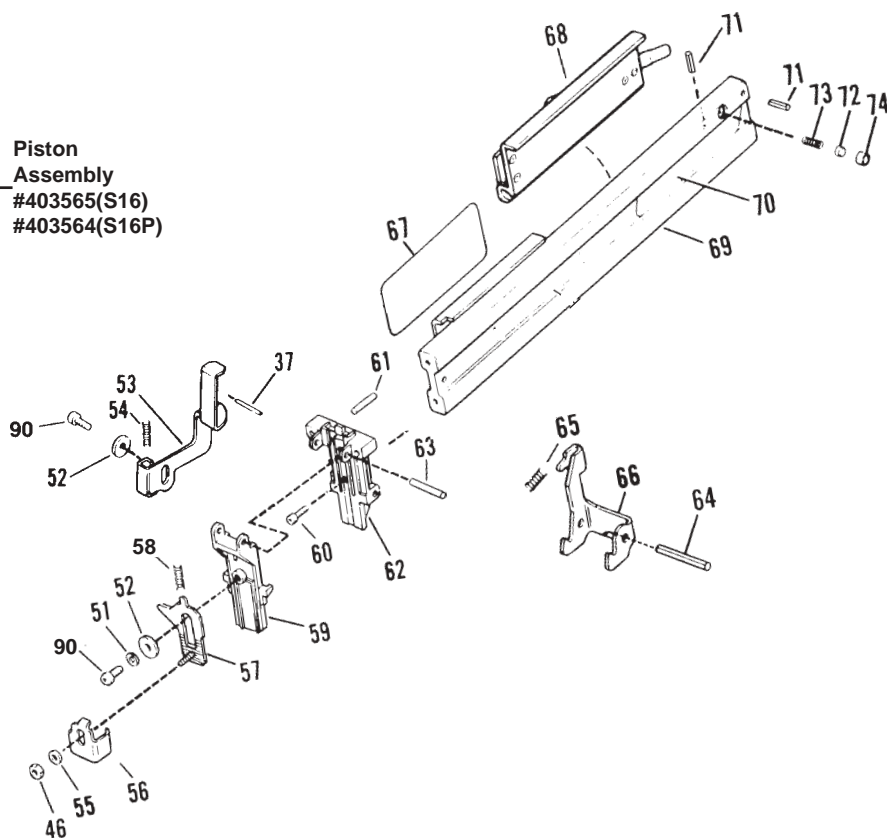
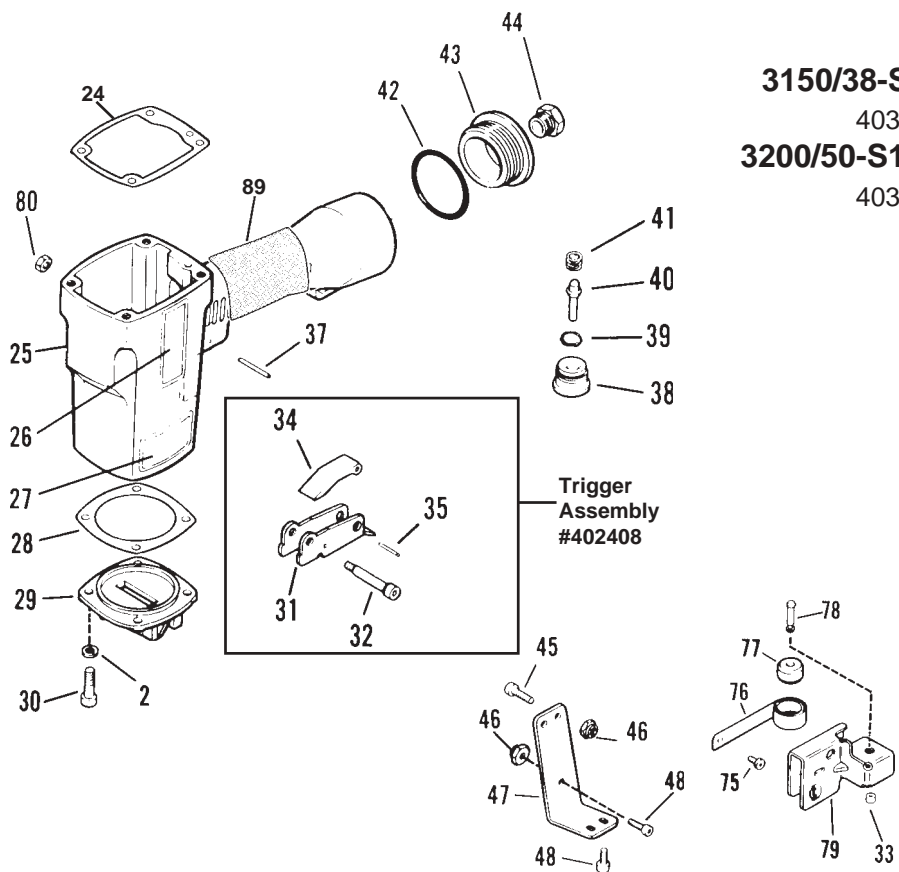
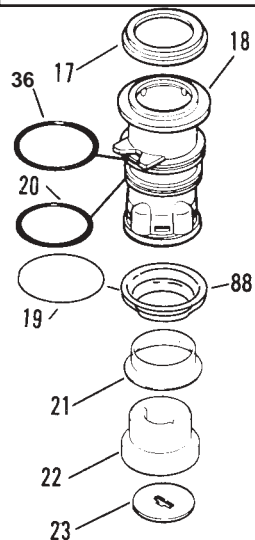
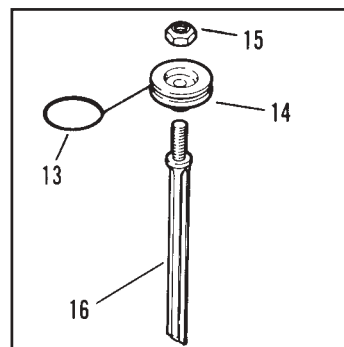
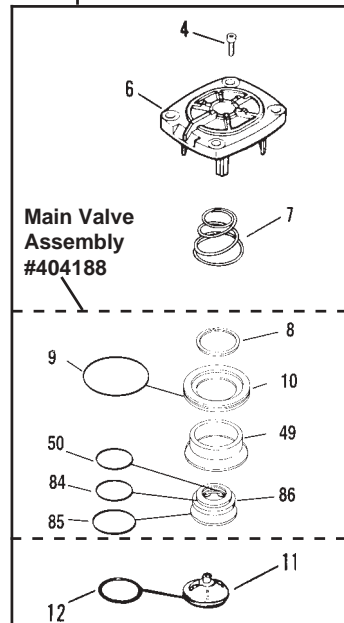

⚠ WARNING
All parts must be periodically inspected and replaced if worn or broken. Failure to do this can affect the tool's operation and present a safety hazard.

ACCESSORIES

Sequential Operating Kit

This special attachment is designed for sequential operation (stops "contact" firing). The operator must depress and hold the work contacting element against the worksurface before pulling the trigger. This sequence must be repeated each time the tool drives a fastener.

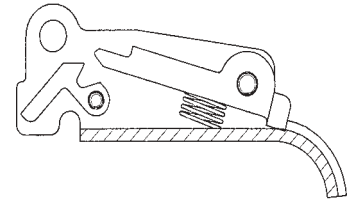

Part No. 406006

Remote Fire Valve

This valve via a positive air signal allows a machine mounted tool to be operated from an automatic air valve or foot pedal system.

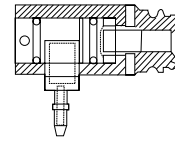

Part No. 1X0713

Lubricants and Loctite

Chemplex 710 Lubricant 1 lb.

Part No. 403734

Lubricant 5 gram tubes

Part No. 219188

Loctite 242 (Blue) 1 oz.

Part No. 093500

Lubricating Oil 16 oz.

Part No. 403720

Lubricating Oil 8 oz. with Antifreeze

Part No. 219090



Belt Hook

Attaches to cap of tool enabling you to carry tool on belt holder (offered below).

Part No. 219017

Belt Hook Holder

Attaches to work belt and carries tool using the above belt hook.

Part No. 219028

Large Nylon Tool Bag

Part No. 219246

Safety Glasses

Clear

Part No. 402510

Tinted

Part No. 402512

Vinyl Siding Work Contacting Element

This attachment allows the WCE to be adjusted to ensure the gap between the staple and siding. This enables positive placement of staple leg in center of siding slot which eliminates cracking.

(for 3150) Part No. 219050

(for 3200) Part No. 219051

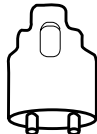

Standard Crown Stapler Repair Kit

This kit repairs all air leaks except for the trigger valve.

Part No. 219223

Trigger Valve Repair Kit

This kit repairs all trigger valve air leaks.

Part No. 219224

SAFETY INSTRUCTIONS

WEAR EYE AND HEARING PROTECTION



Always wear hearing protection and eye protection devices, including side shields when operating or working in the vicinity of a tool.

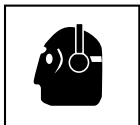

Never use any bottled air or gases such as oxygen to operate the tool since they could cause the tool to explode.

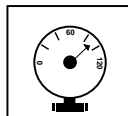
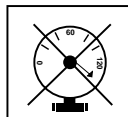

DO NOT EXCEED MAXIMUM RECOMMENDED AIR PRESSURE

Operate the tool using only the recommended air pressure. Do not exceed the maximum air pressure marked on the tool. Be sure the air pressure gauge is operating properly and check it at least twice a day.



An Illinois Tool Works Company
888 Forest Edge Drive
Vernon Hills, Illinois 60061